

SM9001

SURFACE/VOLUME RESISTANCE MEASUREMENT ELECTRODE

SM9002

VERIFICATION FIXTURE FOR SURFACE RESISTANCE MEASUREMENT

Instruction Manual

EN

May 2019 Revised edition 3
 SM9001A981-03 19-05H



1.800.561.8187

www.itm.com

information@itm.com

Warranty Certificate

HIOKI

Model	Serial number	Warranty period
		Three (3) years from date of purchase (___ / ___)

Customer name: _____
 Customer address: _____

- Important**
- Please retain this warranty certificate. Duplicates cannot be reissued.
 - Complete the certificate with the model number, serial number, and date of purchase, along with your name and address. The personal information you provide on this form will only be used to provide repair service and information about Hioki products and services.

This document certifies that the product has been inspected and verified to conform to Hioki's standards. Please contact the place of purchase in the event of a malfunction and provide this document, in which case Hioki will repair or replace the product subject to the warranty terms described below.

Warranty terms

- The product is guaranteed to operate properly during the warranty period (three [3] years from the date of purchase). If the date of purchase is unknown, the warranty period is defined as three (3) years from the date (month and year) of manufacture (as indicated by the first four digits of the serial number in YYMM format).
- If the product came with an AC adapter, the adapter is warranted for one (1) year from the date of purchase.
- The accuracy of measured values and other data generated by the product is guaranteed as described in the product specifications.
- In the event that the product or AC adapter malfunctions during its respective warranty period due to a defect of workmanship or materials, Hioki will repair or replace the product or AC adapter free of charge.
- The following malfunctions and issues are not covered by the warranty and as such are not subject to free repair or replacement:
 - Malfunctions or damage of consumables, parts with a defined service life, etc.
 - Malfunctions or damage of connectors, cables, etc.
 - Malfunctions or damage caused by shipment, dropping, relocation, etc., after purchase of the product
 - Malfunctions or damage caused by inappropriate handling that violates information found in the instruction manual or on precautionary labeling on the product itself
 - Malfunctions or damage caused by a failure to perform maintenance or inspections as required by law or recommended in the instruction manual
 - Malfunctions or damage caused by fire, storms or flooding, earthquakes, lightning, power anomalies (involving voltage, frequency, etc.), war or unrest, contamination with radiation, or other acts of God
 - Damage that is limited to the product's appearance (cosmetic blemishes, deformation of enclosure shape, fading of color, etc.)
 - Other malfunctions or damage for which Hioki is not responsible
- The warranty will be considered invalidated in the following circumstances, in which case Hioki will be unable to perform service such as repair or calibration:
 - If the product has been repaired or modified by a company, entity, or individual other than Hioki
 - If the product has been embedded in another piece of equipment for use in a special application (aerospace, nuclear power, medical use, vehicle control, etc.) without Hioki's having received prior notice
- If you experience a loss caused by use of the product and Hioki determines that it is responsible for the underlying issue, Hioki will provide compensation in an amount not to exceed the purchase price, with the following exceptions:
 - Secondary damage arising from damage to a measured device or component that was caused by use of the product
 - Damage arising from measurement results provided by the product
 - Damage to a device other than the product that was sustained when connecting the device to the product (including via network connections)
- Hioki reserves the right to decline to perform repair, calibration, or other service for products for which a certain amount of time has passed since their manufacture, products whose parts have been discontinued, and products that cannot be repaired due to unforeseen circumstances.

Introduction

Thank you for purchasing the HIOKI Model SM9001 Surface/Volume Resistance Measurement Electrode and the HIOKI Model SM9002 Verification Fixture for Surface Resistance Measurement. To obtain maximum performance from the device, please read this manual first, and keep it handy for future reference.

Initial Inspection

When you receive the device, inspect it carefully to ensure that no damage occurred during shipping. If damage is evident, or if it fails to operate according to the specifications, contact your dealer or Hioki representative.

Overview

The SM9001, an electrode for measuring the surface resistance and volume resistance of flat samples, is an optional product designed for use with Hioki Super Megohm Meters and Digital Super Megohm Meters/Micro-ammeters. It complies with JIS C 2170 (IEC 61340-2-3) and is capable of reliable measurement in applications ranging from evaluation of electrostatic countermeasures to high-resistance measurement in materials development and other fields.

Safety Information

This manual contains information and warnings essential for safe operation of the device and for maintaining it in safe operating condition. Before using it, be sure to carefully read the following safety precautions.

⚠ DANGER

Mishandling this device during use could result in injury or death, as well as damage to the device. Be certain that you understand the instructions and precautions in the manual before use. We disclaim any responsibility for accidents or injuries not resulting directly from device defects.

Safety Symbols

	Indicates cautions and hazards. When the symbol is printed on the instrument, refer to a corresponding topic in the Instruction Manual.
	Indicates DC (Direct Current).

The following symbols in this manual indicate the relative importance of cautions and warnings.

⚠ DANGER Indicates an imminently hazardous situation that will result in death or serious injury to the operator.

⚠ WARNING Indicates a potentially hazardous situation that may result in death or serious injury to the operator.

⚠ CAUTION Indicates a potentially hazardous situation that may result in minor or moderate injury to the operator or damage to the device or malfunction.

NOTE Indicates advisory items related to performance or correct operation of the device.

Stowing the electrode in its carrying case

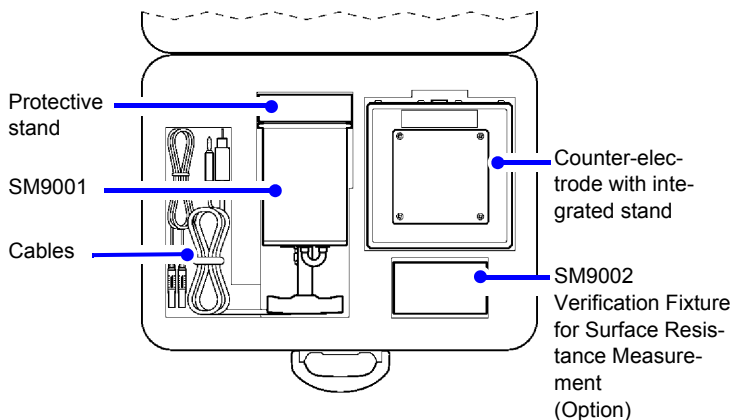

Usage Notes

Follow these precautions to ensure safe operation and to obtain the full benefits of the various functions.

⚠ DANGER

- Before using the device, make sure that the insulation on the cable is undamaged and that no bare conductors are improperly exposed. Using the device in such conditions could cause an electric shock, so contact your dealer or Hioki representative for repair.
- The maximum rated voltage between input terminals and ground is 1000 VDC. Attempting to measure voltages exceeding 450V with respect to ground could damage the device and result in personal injury.

⚠ WARNING







- To avoid shock and short circuits, turn off all power before connecting the device.
- Do not allow the device to get wet, and do not take measurements with wet hands. This may cause an electric shock.
- Do not use the device where it may be exposed to oil, chemicals, or solvents. Contact with these substances may cause cracking in the device, resulting in damage or electric shock.

⚠ CAUTION

- Do not slant the device or place it on top of an uneven surface. Dropping or knocking down the device can cause injury or damage to the device.
- This device is not designed to be entirely water- or dust-proof. Do not use it in an especially dusty environment, nor where it might be splashed with liquid. This may cause damage.
- Do not store or use the device where it could be exposed to direct sunlight, high temperature or humidity, or condensation. Under such conditions, the device may be damaged and insulation may deteriorate so that it no longer meets specifications.
- To avoid damage to the device, protect it from physical shock when transporting and handling. Be especially careful to avoid physical shock from dropping.
- To prevent an electric shock accident, confirm that the white or red portion (insulation layer) inside the cable is not exposed. If a color inside the cable is exposed, do not use the cable.

Instrument Installation

Avoid the following locations that could cause an accident or damage to the device.

	Exposed to direct sunlight Exposed to high temperature		In the presence of corrosive or explosive gases
	Exposed to water, oil, other chemicals, or solvents Exposed to high humidity or condensation		Exposed to strong electromagnetic fields Near electromagnetic radiators
	Exposed to high levels of particulate dust		Near induction heating systems (e.g., high-frequency induction heating systems and IH cooking utensils)
	Subject to vibration		

Specifications

General Specifications

Operating environment	Indoors, altitude up to 2000 m (6562 feet), Pollution degree 2
Operating temperature and humidity	0°C to 40°C (32°F to 104°F), 80%RH or less. (non-condensing)
Storage temperature and humidity	-10°C to 50°C (14°F to 122°F), 80%RH or less. (non-condensing)
Dielectric strength	Between input terminals (together) and SM9001 enclosure: 7504 V DC, for 15 seconds

Electrode structure	Main electrode : Floating structure (isolated from ring electrode) Ring electrode : Fixed to enclosure
Dimensions	Approx. φ100×223H mm (including handle and barrier) Approx. φ3.94" × 8.78"H Connection Cable length: Approx. 1 m
Mass	Approx. 2.5 kg (88.2 oz.) Instruction manual 1 Counter-electrode with integrated stand.... 1 Dimensions: Approx. 154W×155D×25H mm (6.06"W × 6.10"D × 0.98"H), Mass: Approx. 1.2 kg (42.3 oz.)
Accessories	Electrode dimensions: Approx. 100 mm×100 mm Protective stand 1 Carrying case (with lock) 1 Short bar 1 Counter-electrode connection cable 1 Cable length : Approx. 700 mm (27.56") Mass : Approx. 27.0 g (1.0 oz.)
Electrodes	Electrode rubber Material: Conductive rubber Profile : Main electrode ; φ30.5 mm (D1), Thickness: 3 mm : Ring electrode ; φ57.0 mm (inner diameter)(D2), φ63.0 mm (outer diameter), Thickness: 3 mm
Option	Model SM9002 Verification Fixture for Surface Resistance Measurement Temperature and humidity range during inspection 18°C to 28°C (64.4°F to 82.4°F), 60% RH or less. (non-condensing)
Product warranty period	3 years (The electrode rubbers, which are consumables, are not covered by the warranty.)

Measurement functionality

Reference standards	IEC61340-2-3:2000 JIS C2170:2004
Measurement items	Surface resistance measurement [Rs] The surface resistance of the sample is measured after placing the electrode at roughly the center of the sample or at least 10 mm from the edge of the sample. Volume resistance measurement [Rv] The volume resistance of the sample is measured after placing the sample on the counter-electrode with integrated stand and then placing the electrode at roughly the center of the sample or at least 10 mm from the edge of the sample. *Switch measurement targets by switching terminal connections.
Measurement ranges	Resistance measurement range: 1×10 ³ Ω to 1×10 ¹³ Ω The minimum resistance measurement is determined by the specifications of DSM series and SM series Super Megohm Meters.
Electrode internal resistance	Between main electrode and ring electrode : 1×10 ¹⁴ Ω or more
Maximum rated voltage to earth	1000 V DC
Resistance when shorted	Between main electrode and ring electrode : 1×10 ³ Ω or less

Supported models Super Megohm Meter SM series, DSM series

Conversion to resistivity (JIS C2170:2004/ IEC 61340-2-3:2000)

$$\text{Surface resistivity: } \rho_s = \frac{\pi \cdot (D2+D1)}{D2-D1} \times (\text{Measured value})$$

$$\text{Volume resistivity: } \rho_v = \frac{\pi \cdot D1^2}{4t} \times \frac{(\text{Measured value})}{10}$$

- ρ_s : Surface resistivity (Ω)
- ρ_v : Volume resistivity (Ω•mm)
- π : Circular constant = 3.14
- D1 : Diameter of the main electrode (mm)
- D2 : Diameter of the ring electrode (mm)
- t : Thickness of sample (mm)

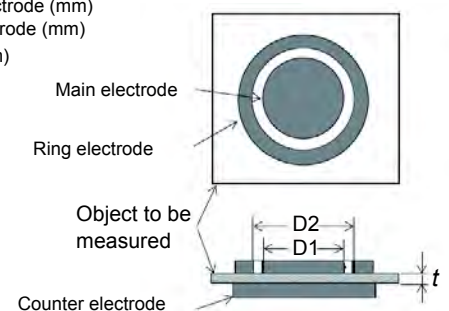

1.800.561.8187
www.itm.com
information@itm.com

Names of Parts

Top of SM9001

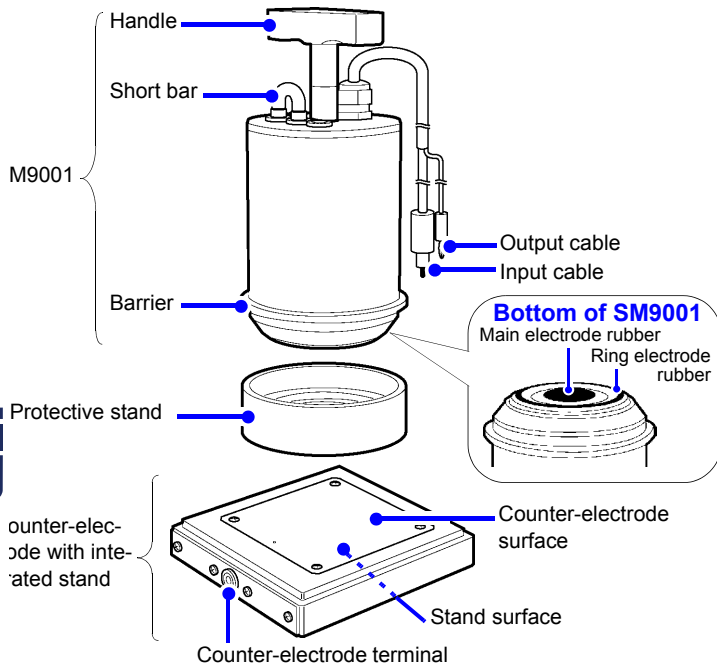
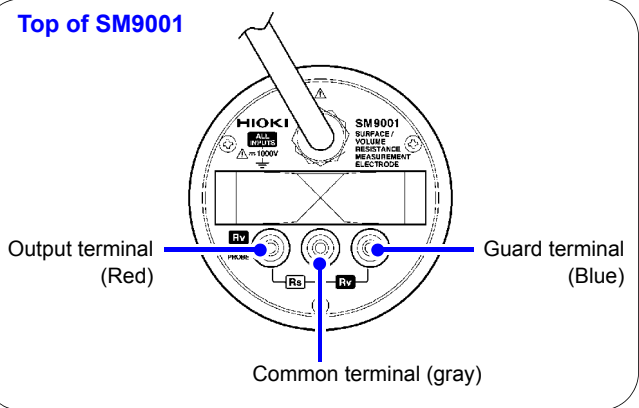

CAUTION

- To avoid breaking the cable, do not bend or pull it.
- Avoid stepping on or pinching cables, which could damage the cable insulation.
- The cable is hardened under the 0 degree or colder environment. Do not bend or pull it to avoid tearing its shield or cutting cable.
- Keep the cables well away from heat sources, as bare conductors could be exposed if the insulation melts.

NOTE

- When placing the SM9001 in contact with the sample, do so gently and from directly above the sample.
- Check the surface of the electrode rubber for dirt, foreign matter, scratches, or other impediments to proper operation.
- Place the measurement target (or when measuring volume resistance, the counter-electrode) on a level surface.
- While performing measurement, avoid contact with the SM9001. Avoid subjecting the SM9001 to excessive force by pulling on or twisting cables.
- Do not subject the electrode rubber to twisting (friction) or mechanical shock.
- If unable to obtain stable measurement results, clean the surface of the SM9001's electrode rubber with industrial-use ethanol (use a concentration of at least 95%). If cleaning fails to yield improvement, remove the SM9001's electrode rubber and clean the entire unit with industrial-strength ethanol (use a concentration of at least 95%). For more information, see "Removing and reattaching the electrode rubber."
- To protect the electrode rubber, place the SM9001 on its protective stand when not using it to measure samples and avoid sitting it directly on the bottom surface. When placing the SM9001 on the protective stand, do so carefully and avoid subjecting the stand to excessive force.

Measuring surface resistance

1. Connect the short bar to the surface resistance measurement [Rs] terminals (common terminal [gray] and output terminal [red]).
2. Place the sample on the stand surface of the counter-electrode with integrated stand and gently place the SM9001 on top of the sample at least 10 mm from the edge, lowering it from directly above.
3. Verify that no voltage is being output from the Super Megohm Meter. Connect the input cable to the Super Megohm Meter's input terminal and the output cable to the Super Megohm Meter's output terminal.
4. Operate the Super Megohm Meter to start measurement. For more information about measurement, see the Super Megohm Meter's instruction manual.

Measuring volume resistance

1. Connect the short bar to the volume resistance measurement [Rv] terminals (common terminal [gray] and guard terminal [blue]).
2. Place the sample on the counter-electrode surface of the counter-electrode with integrated stand and gently place the SM9001 on top of the sample at least 10 mm from the edge, lowering it from directly above so that it does not extend beyond the counter-electrode surface.
3. Connect the included counter-electrode connection cable to the output terminal (red) and the counter-electrode terminal.
4. Verify that no voltage is being output from the Super Megohm Meter. Connect the input cable to the Super Megohm Meter's input terminal and the output cable to the Super Megohm Meter's output terminal.
5. Operate the Super Megohm Meter to start measurement. For more information about measurement, see the Super Megohm Meter's instruction manual.

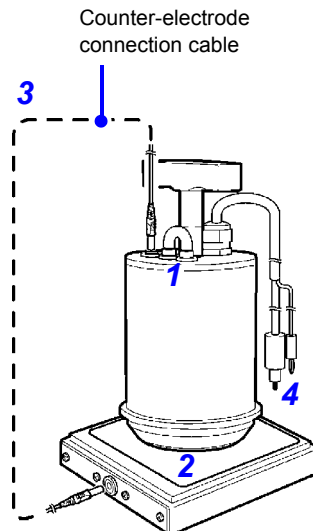

Pre-Operation Inspection

Before using the device, check it and verify that it operates properly to make sure that it suffered no damage during storage or transportation. Check the following before using the device.

Check Items	Diagnose and Solution
Is the insulation of the cable to be used damaged, or is bare metal exposed?	Do not use a damaged cable doing so may result in electric shock.
Is there a break in a cable? Between the main electrode rubber and the input cable's inner wire Between the guard terminal (blue) and the input cable's outer wire Between the output terminal (red) and the output cable	Have the SM9001 repaired if there is a break in a cable.
Is the electrode's internal resistance at least $1 \times 10^{14} \Omega$? • Place the SM9001 in a horizontal orientation and take a measurement while the main electrode and ring electrode are not in contact with anything. (Applied voltage: 100 V/1 min.)	Remove dirt and other foreign matter from between the main electrode and ring electrode.

Measurement Procedures

WARNING

When measuring insulation resistance, a dangerous voltage will be applied to the electrodes in the START, MEASURE, and CHARGE states. To avoid electric shock, do not touch the electrodes.

Maintenance and Service

- If damage is suspected, check the "Before Returning for Repair" section before contacting your dealer or Hioki representative.
- Use the original packing materials when transporting the device, if possible.

Cleaning

To clean the device, wipe it gently with a soft cloth moistened with water or mild detergent. Never use solvents such as benzene, acetone, ether, ketones, thinners or gasoline, as they can deform and discolor the case. Clean the electrode rubber with industrial-use ethanol (use a concentration of at least 95%).

About electrode rubber

Removing and reattaching the electrode rubber

- The electrode rubber can be removed by gripping it carefully so as not to scratch it and pulling it off.
- The electrode rubber has a top and a bottom. Check for proper orientation before reattaching it. The surface that makes contact with the measurement target is thinner, while the surface that makes contact with the metal portion of the SM9001 is thicker.
- Gently insert the electrode rubber and then fit it tightly against the metallic surface by pushing it against a level base such as the counter-electrode.

Contact your dealer or Hioki representative if:

- The electrode rubber no longer covers the adjacent metal
- The electrode rubber exhibits visible damage
- The electrode rubber is excessively dirty and efforts at cleaning prove to be ineffective

Before Returning for Repair

If abnormal operation occurs, check the following items.

Symptom	Check Items	Solution
The resistance value is abnormal.	Are the terminals connected properly?	Connect the terminals securely.
	Has the short bar been connected properly?	Connect the short bar to the proper pair of terminals for the type of measurement you intend to perform.
	Is the electrode rubber dirty?	Clean the electrode rubber.

SM9002 Verification Fixture for Surface Resistance Measurement

The SM9002 Verification Fixture for Surface Resistance Measurement is a system verification fixture for use in measuring surface resistance as required by Section 8.4 of JIS C 2170:2004 (IEC 61340-2-3:2000). The SM9002 is an option designed specifically for use with the SM9001 and cannot be used for system verification of other devices.

Specifications

General Specifications

Operating environment	Indoors, altitude up to 2000 m (6562 feet), Pollution degree 2
Operating temperature and humidity	18°C to 28°C (64.4°F to 82.4°F), 60% RH or less. (non-condensing)
Storage temperature and humidity	-10°C to 50°C (14°F to 122°F), 80% RH or less. (non-condensing)
Dielectric strength	Between electrodes (together) and SM9002 enclosure: 1120 V DC, for 15 seconds
Electrode structure	High-resistance: Chrome-plated metal (brass) Low-resistance: Gold-plated copper cladding formed on PC board
Dimensions	Approx. $\phi 100 \times 56H$ mm ($\phi 3.94" \times 2.20"H$)
Mass	Approx. 300 g (10.6 oz.)
Product warranty period	3 years

Measurement functionality

Measurement items	Low-resistance measurement Resistance measurement electrodes connected to a measuring instrument are secured to the inspection fixture, and a judgment is made concerning whether the system is functioning properly. (Test voltage: 10 V DC) Verification consists of a series of repeated measurements while varying the phase position of the fixture and electrodes by 90°.
	High-resistance measurement Resistance measurement electrodes connected to a measuring instrument are secured to the inspection fixture, and a judgment is made concerning whether the system is functioning properly. (Test voltage: 100 V DC)

Circuit design	Low-resistance measurement The circuit consists of contact electrodes arranged in a radial pattern at the center and ring measurement electrode positions and twenty $10 \text{ M}\Omega \pm 1\%$ resistors placed at an even interval. The circuit forms a $500 \text{ k}\Omega \pm 1\%$ parallel connection.
	High-resistance measurement The circuit consists of contact electrodes placed at the center and ring measurement electrode positions and one $1 \text{ T}\Omega \pm 5\%$ resistor.

Maximum rated voltage to earth	100 V DC
--------------------------------	----------

Appearance

High-resistance test surface

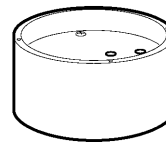

Low-resistance test surface

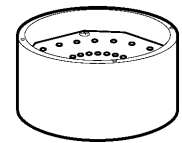

Using the fixture

The following describes how the fixture is used in a typical application. Customers needing to perform a rigorous verification process that complies with JIS C 2170:2004 should be sure to check the actual JIS document.

Low-resistance measurement

1. Connect the short bar to the surface resistance measurement [Rs] terminals (common terminal [gray] and output terminal [red]).
2. Gently place the SM9001 on the SM9002's low-resistance test surface, lowering it from directly above.
3. Apply 10 V and read the resistance value after 15 sec.
4. Stop applying the voltage. Lift up the SM9001 and rotate the SM9002 90°.
5. Repeat steps (3) and (4) until the SM9002 has been rotated through 360°.

If the acquired resistance values are both within 5% of 500 k Ω , then the system is operating properly.

High-resistance measurement

1. Connect the short bar to the surface resistance measurement [Rs] terminals (common terminal [gray] and output terminal [red]).
2. Gently place the SM9001 on the SM9002's high-resistance test surface, lowering it from directly above.
3. Apply 100 V and verify that a stable resistance value of $1 \text{ T}\Omega \pm 5\%$ is obtained.

NOTE

- Some Super Megohm Meter models are capable of generating a terminal-to-ground voltage of 1,000 V, but the SM9002 is rated for a maximum terminal-to-ground voltage of 100 V.
- Check the SM9002 test surface and the SM9001 electrode rubber for dirt, foreign matter, scratches, or other impediments to proper operation.
- While performing measurement, avoid contact with the SM9001. Avoid subjecting the SM9001 to excessive force by pulling on or twisting cables.
- Due to the delicate nature of the contact with the SM9001, you may obtain out-of-range measured values even if the product is operating properly if the SM9001 has not been placed on the surface from directly above. Remove and then reposition the SM9001 if the value is out of range.
- If unable to obtain stable measurement results, clean the surface of the SM9001's electrode rubber and the SM9002 test surface with industrial-use ethanol (use a concentration of at least 95%). If cleaning fails to yield improvement, remove the SM9001's electrode rubber and clean the entire unit with industrial-strength ethanol (use a concentration of at least 95%). For more information, see "Removing and reattaching the electrode rubber."
- Place the SM9002 on a level surface.
- The SM9002 should be stored in a pouch inside the SM9001's included carrying case.
- Do not touch the test surface or get it dirty.