



PW Series

Wet Media Differential Pressure Transducer

Product Overview

The PW Series pressure transducer measures the differential pressure across pumps, filters, heat exchangers, and other non-corrosive wet media. Several operational pressure ranges are available, and the analog output is user selectable (4-20 mA, 0-5 V, or 0-10 V). PW Series devices are warranted to meet accuracy specifications for a period of five years.

CE available

NOTICE

- This product is not intended for life or safety applications.
- Do not install this product in hazardous or classified locations.
- Read and understand the instructions before installing this product.
- Turn off all power supplying equipment before working on it.
- The installer is responsible for conformance to all applicable codes.

No responsibility is assumed by Veris Industries for any consequences arising out of the use of this material.

Product Identification

	Local Display	NIST	Operational Range ¹	US or EU
PW	<input type="checkbox"/>	<input type="checkbox"/>	<input type="checkbox"/>	<input type="checkbox"/>
	L = LCD Display X = No Display	N = NIST X = None	03 = 0-50 psig 04 = 0-100 psig 05 = 0-250 psig 06 = 0-3.5 barg ² 07 = 0-7.0 barg ² 08 = 0-17 barg ²	S = Standard ³ C = CE

¹ Select operational range according to maximum gauge pressure, NOT differential pressure.

Example: High gauge pressure=90 psig, Select 100 psig model (04).

² barg models use BSPT threads on sensor fittings.

³ Not available with barg units.

Specifications

Media Compatibility	17-4 PH stainless steel
Input Power	12 to 30VDC, 24VAC nom.
Maximum Current Draw	DC: 125mA; AC: 280mA
Output	3-wire transmitter; user-selectable 4-20mA/0-5V/0-10V ¹
Status Indication	Dual color LED
Proof Pressure	2x max. F.S. range
Burst Pressure	5x max. F.S. range
Accuracy at 25°C²	Ranges A, B, C: ±1% F.S. ³ Range D: ±2% F.S. ³
Surge Damping	Electronic; 5-second averaging
Temperature Compensated Range	0° to 50°C (32° to 122°F); TC Zero <1.5% of product F.S. per sensor; TC Span <1.5% of product F.S. per sensor
Sensor Operating Range	-20° to 85°C (-4° to 185°F)
Operating Environment	-10° to 55°C (14° to 131°F); 10-90% RH noncondensing
Long Term Stability	±0.25%
Zero Adjust	Pushbutton auto-zero and digital input (2-position terminal block)
Fittings	psig models: 1/8" NPT female thread, stainless steel 17-4 PH barg models: 1/8" BSPT female thread, stainless steel 17-4 PH
Physical	White powder-coated aluminum
PRESSURE RANGES	
0-50 psig	5/10/25/50 psid
0-100 psig	10/20/50/100 psid
0-250 psig	25/50/125/250 psid
0-3.5 barg	0.35/0.7/1.75/3.5 bard
0-7.0 barg	0.7/1.4/3.5/7.0 bard
0-17 barg	1.7/3.4/8.5/17.0 bard

To conform to EMC Standards, use shielded cabling. Technical information is available from the factory on request or on our website (www.veris.com/ce)

¹ Minimum input voltage for 4-20 mA operation: 250 Ω loop (1-5V) = 12 VDC; 500 Ω loop (2-10V) = 15 VDC

Minimum input voltage for volt operation: 0-5 VDC output = 12 VDC; 0-10 VDC output = 15 VDC

² Accuracy combines linearity, hysteresis, and repeatability.

³ F.S. is defined as full span of selected range in bidirectional mode.

Dimensions

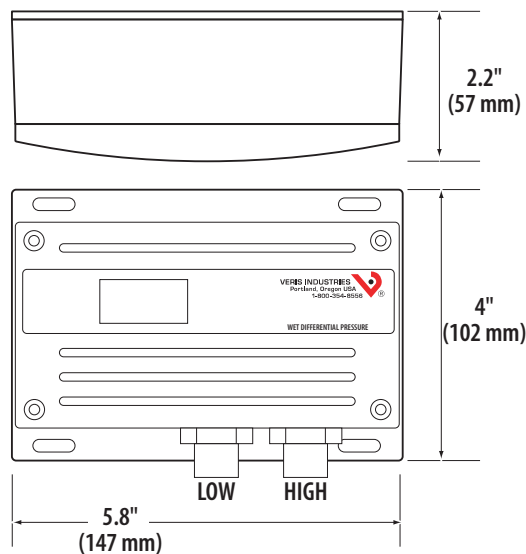

Installation



Observe precautions for handling static sensitive devices to avoid damage to the circuitry that is not covered under the factory warranty.

1. Find a suitable mounting position near the location to be measured. Mount the PW housing using the self-tapping screws provided.
2. Remove the lid from the housing to reveal the board. Wire the PW terminals to the power source and to the digital control system as shown. Configure the jumpers for desired operating parameters. Replace the cover.

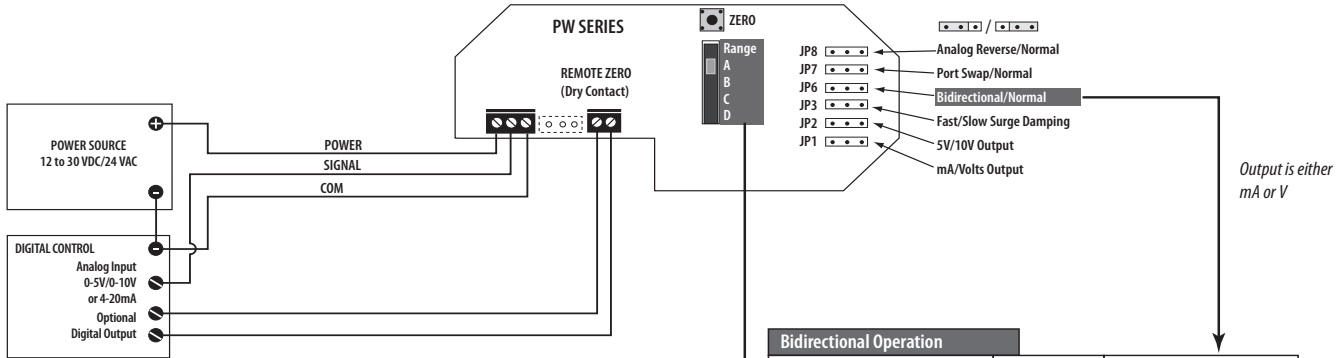

Bidirectional Operation				
Input Conditions		Result	Outputs Read	
HI PORT	LO PORT	DP	4-20mA	0-10V
100 psi	0 psi	+100 psi	20mA	10V
100 psi	50 psi	+50 psi	16mA	7.5V
50 psi	50 psi	0 psi	12mA	5V
50 psi	100 psi	-50 psi	8mA	2.5V
0 psi	100 psi	-100 psi	4mA	0V
17.0 bar	0 bar	+17.0 bar	20mA	10V
17.0 bar	8.5 bar	+8.5 bar	16mA	7.5V
8.5 bar	8.5 bar	0 bar	12mA	5V
8.5 bar	17.0 bar	-8.5 bar	8mA	2.5V
0 bar	17.0 bar	-17.0 bar	4mA	0V

e.g. PW-04
e.g. PW-08

Use the Range switch to select F.S. differential pressure.

Model	Range (psi)			
	A	B	C	D
PW-03	50	25	10	5
PW-04	100	50	20	10
PW-05	250	125	50	25

e.g. PW-04

Model	Range (bar)			
	A	B	C	D
PW-06	3.5	1.75	0.7	0.35
PW-07	7.0	3.5	1.4	0.7
PW-08	17.0	8.5	3.4	1.7

e.g. PW-08

Jumper	Options	Notes
JP1	Voltage (V) or Current (mA)	
JP2	0-10V or 0-5V output span	Use only if JP1 is set to V mode.
JP3	Slow or Fast	Slow mode provides 5 second averaging for surge damping.
JP6	Normal or Bidirectional	Normal: 0 to F.S. pressure Bidirectional: -F.S. pressure to +F.S. pressure; output reads 1/2 when pressure is zero.
JP7	Normal or Port Swap	Reverses polarity of the pressure ports (i.e. makes the LO port operate as the HI port and vice versa); used when the sensor is incorrectly plumbed.
JP8	Normal or Analog Reverse	Normal: output increases as pressure increases; Reverse: output is maximum when pressure differential is zero and decreases as pressure increases.

Installation (cont.)

3. Connect tubing to the high and low ports on the PW.

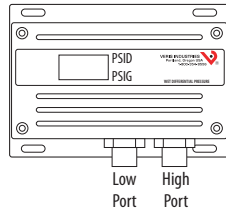

4. Connect the other ends of the tubing to a pipe or duct, across the pump, filter, or other pressure differential.

Notes

During operation, the LCD shows two pressure values. The value adjacent to the PSID label shows the differential pressure, while the value adjacent to the PSIG label shows the high port gauge pressure. The gauge pressure value is read from the high port if JP7 is in the Normal position. If this jumper is in the Port Swap position, the PSIG value is read from the low port, and the value is usually a negative number.

This product uses a half-wave rectifier power supply. If the installer is using a transformer to power the device, do not use the same transformer to power other devices utilizing non-isolated full-wave power supplies.

Optional: Connect the Zero terminals to the digital output (contact closure) of the control system. The Zero input is for dry-contact only. Do not apply voltage to the Zero terminals.

To use the auto zero function, press and hold the Zero button for 2 seconds or provide contact closure on the auxiliary 'Remote Zero' terminal to reset the output to zero pressure. To protect the device from accidental zeroing, this feature is only enabled when the detected pressure is within 5% of factory calibration.

LED Blink Codes

LED Color	Status
Solid Green	Normal operation.
Flashing Green	Low > High; use port swap jumper or bidirectional mode.
Solid Red	Differential pressure is too high; select a higher pressure range.
Flashing Red	Gauge pressure over sensor range; reduce line pressure or replace with a higher range device.