

NOTICE:

As a result of a temporary parts shortage, the 4-position slide switch used for range selection has been replaced with a 5-position slide switch in a limited period of production runs. See pages 3-4 for details.



PWR Series

Wet Media Remote Pressure Transducer

Product Overview

The PWR Series remote pressure transducers are designed for differential pressure applications. The sensors are remotely installed on existing plumbing runs. The PWR is available with either armored (6 ft.) or shielded (10 or 20 ft) sensor cables, and it requires a 15 to 30 Vdc or 24 Vac power source to generate its output. The PWR is warranted for a period of five years.



NOTICE

- This product is not intended for life or safety applications.
- Do not install this product in hazardous or classified locations.
- Read and understand the instructions before installing this product.
- Turn off all power supplying equipment before working on it.
- The installer is responsible for conformance to all applicable codes.

If this product is used in a manner not specified by the manufacturer, the protection provided by the product may be impaired. No responsibility is assumed by the manufacturer for any consequences arising out of the use of this material.

Product Identification

	Display	NIST	Operational Range	Media	Cable Length	Cable
PWR	<input type="checkbox"/> L = LCD	<input type="checkbox"/> X = Standard	<input type="checkbox"/> 03 = 0 to 50 psid 04 = 0 to 100 psid 05 = 0 to 250 psid	<input type="checkbox"/> S = Water	<input type="checkbox"/> 006 = 6 ft (1.8 m) 010 = 10 ft (3.1 m) 020 = 20 ft (6.1 m)	<input type="checkbox"/> Blank = Standard* A = Armored**

*Standard cable available only in 10 ft and 20 ft lengths.

**Armored cable available only in 6 ft length.

Note: Extension of total cable length greater than 20 feet may result in reduced accuracy.

Specifications

Media Compatibility	17-4 PH stainless steel
Input Power	15 to 30 Vdc, 24 Vac nom. 50/60 Hz*
Maximum Current Draw	DC: 125 mA; AC: 280 mA
Output	3-wire transmitter; user-selectable 4 to 20mA/0 to 5V/0 to 10V
Status Indication	Dual color LED
Proof Pressure	2x max. F.S. range**
Burst Pressure	5x max. F.S. range**
Accuracy at 25°C***	Ranges A and B: ±1% F.S. typical Range C: ±1.5% F.S. typical Range D: ±2% F.S. typical (For less than or equal to 20 ft. (6.1 m) cable length)
Surge Damping	Electronic; 1 or 5 second averaging
Long Term Stability	±0.25%
Zero Offset (Bidirectional and Port Swap Modes Only)	0.5%
Zero Adjust	Pushbutton auto-zero and digital input (2-position terminal block)
Fittings	¼" NPT male thread, stainless steel 17-4 PH; Overall thread length: 0.59" (conforms to ANSI/ASME B1.20.1 standard)
OPERATIONAL RANGES	
0 to 50 psig	5/10/25/50 psid
0 to 100 psig	10/20/50/100 psid
0 to 250 psig	25/50/125/250 psid

Specifications (cont.)

OPERATING CONDITIONS	
Temperature Compensated Range	0 to 50 °C (32 to 122 °F) TC Zero <1.5% of product F.S. per sensor; TC Span <1.5% of product F.S. per sensor
Sensor Operating Range	-20 to 85 °C (-4 to 185 °F)
Operating Environment	-10 to 50 °C (14 to 122 °F); 10 to 90% RH non-condensing
COMPLIANCE INFORMATION	
Approvals	RoHS, IP65 at sensor, CE

* VFD systems and system wiring generate fields that can disrupt electrical devices. Ensure that these fields are minimized and are not affecting the sensor or sensor wiring.

** F.S. is defined as full span of selected range.

*** Accuracy combines linearity, hysteresis, and repeatability.

Dimensions

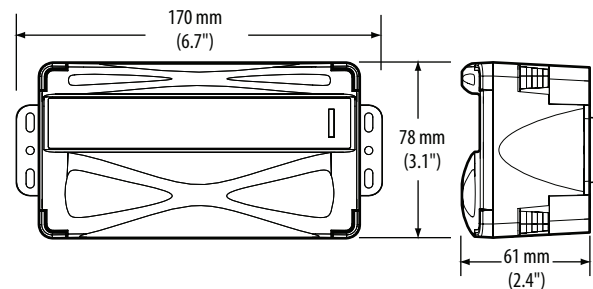

Installation

⚠ Disconnect power from the power source before beginning the installation.



ATTENTION

OBSERVE PRECAUTIONS FOR HANDLING ELECTROSTATIC SENSITIVE DEVICES TO AVOID DAMAGE TO THE CIRCUITRY THAT IS NOT COVERED UNDER FACTORY WARRANTY.

1. Mount the housing using the included screws. Avoid locations where excessive vibrations occur.
2. Remove the housing cover by pressing the corner tabs. There are two tabs on each side of the housing. One side is shown below.

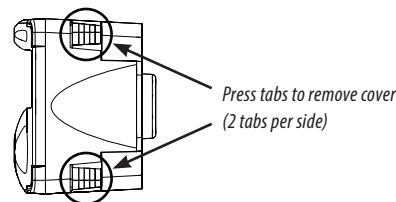

3. Run the digital control and power source wiring and connect to the left-most terminal block.
4. The sensors and monitor assembly are matched at the factory and calibrated as a unit. They must be kept paired to obtain the accuracy stated in the product specifications. Verify that the serial numbers on the sensors match the serial number on the main housing.

Installation (cont.)

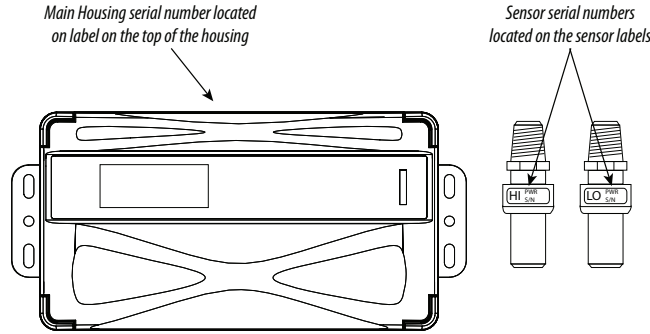

- Run wires from the remote pressure sensor cables and connect to the pair of 4-terminal blocks at the right side of the board. To maintain the correct calibration, it is important not to confuse the high side and the low side. To assist, the sensors are labeled, "HI" and "LO."

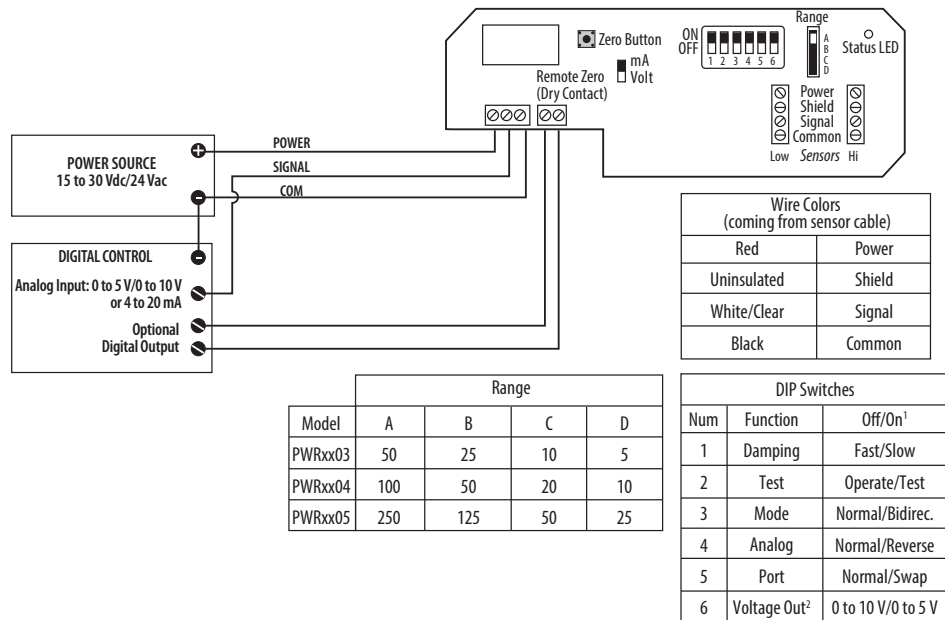

¹. "Off" position is the default setting for all DIP switches.
². Ignored in mA mode.

NOTICE:

As a result of a temporary parts shortage, the 4-position slide switch used for range selection has been replaced with a 5-position slide switch in a limited period of production runs. This will have a minor impact on how the range selection works on the affected models. The 5-position switch will be used in models produced between these dates:

- Start Date: January 21, 2025 (Date Code: 2503)
- End Date: February 7, 2025 (Date Code: 2506)

The extra (fifth) position will align with the "RANGE" text printed on the product PCB. When this position is selected, the product will treat this the same as if range "D" is selected.

The presence of the 5-position switch can be determined one of two ways.

- Look at the date code printed on the product label. If the date code falls between the starting date and ending date listed above, inclusive of those values, then the product will have a 5-position range switch.
- Look at the range selection switch. The switch body will extend slightly beyond the edge of the PCB.

Installation (cont.)

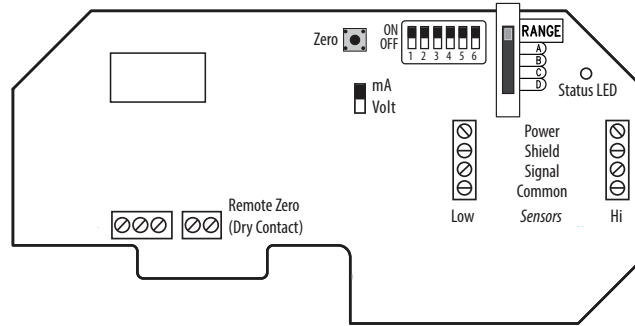

Model	Range (PSI)				
	Extra	A	B	C	D
PWRxx03	5	50	25	10	5
PWRxx04	10	100	50	20	10
PWRxx05	25	250	125	50	25

6. If the sensors are installed on the wrong side, they can be reversed in one of two ways:
 - Swap the cables at the sensor end.
 - Swap the headers at the control unit end.
7. Adjust the switches on the board as desired.
8. Reconnect power to the power source. Check that the green LED illuminates, indicating normal operation. If not, check the wiring.
9. Re-affix the cover onto the housing, ensuring that the cover is properly seated. Do not operate the PWR without the housing cover in place.
10. Choose sensor mounting locations that minimize cable length. Keep the sensor's electronics and the connector dry at all times during the installation process.
 - Make sure that the wires coming from the sensor remain straight for at least three inches (3") from the end of the sensor connector. This ensures that the wires do not put any stress on the connector seal.
 - Wires that bend too close to the connector may stretch the seal and allow water to reach the sensor wiring. If this happens, the IP65 rating may be invalidated.
11. Use plumbing connections of appropriate "tees" or equivalent, made of compatible material. Observe safety precautions for plumbing connections. Release pressure from the system. Tighten sensor connections according to ANSI B1.20.3 (hand tighten plus one turn).

Configuration

Test Mode

Test mode overrides the output to full-scale. If the PWR is configured for current (mA) operation, Test mode sets the output to 20.0 mA. If configured for voltage (VDC) operation, Test mode sets the output to 5.0 VDC or 10.0 VDC (depending on the position of the output selection switch).

Status LED

LED	Status
Solid Green	Normal operation.
Flashing Green	Low > High; use port swap jumper or bidirectional mode.
Solid Red	Differential pressure is too high; select a higher pressure range.
Flashing Red	Gauge pressure over sensor range; reduce line pressure or replace with a higher range device.
Alternating Red/Green Flash	Sensor input is below sensor range. Verify that the sensor is connected correctly.

Auto Zero Function

To automatically reset the output to zero pressure, press and hold the Zero push-button for two seconds or provide contact closure on the auxiliary remote tare terminal. To protect the unit from accidental tare, this feature is enabled only when the detected pressure is within 5% of factory calibration.