

FLUKE®

PV350

Pressure/ Vacuum Transducer Module

Instruction Sheet

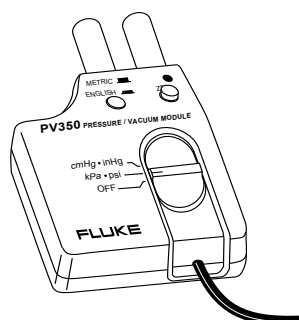

Introduction

The PV350 Pressure/Vacuum Transducer Module (the module) measures gauge pressure; the difference between atmospheric (barometric) pressure and the pressure (or vacuum) applied to the pressure port on the transducer. It then converts that measurement to 1 mV dc per unit. A module and a high-performance digital multimeter (DMM) with min/max function become a datalogger capable of measuring peak high and peak low.

Box Contents

- Pressure/Vacuum Transducer Module
- 1/4 in. male flare to 1/4 in. female pipe thread connector
- 9 V alkaline battery
- Instruction Sheet
- Quick Reference Guide

Safety Information

⚠ Warning

To avoid eye injury, always wear approved safety glasses when working with this instrument.

To avoid injury from pressure explosion:

- **Be sure that pressure is removed before disconnecting any hoses or tubing from the PV350 transducer.**
- **Follow accepted safety procedures for systems on which pressure or vacuum measurements are made.**
- **Make sure the PV350 is serviced by a qualified technician.**

PN 926873 May 1992 Rev. 6, 5/15

© 1999-2015 Fluke Corporation, All rights reserved.

All product names are trademarks of their respective companies.

- To ensure that the module is used safely, follow all safety and operating instructions in this Instruction Sheet. If the module is not used as described in this Instruction Sheet, the safety features of the module might be impaired.
- Do not use the module if the module or fittings look damaged, or if you suspect that the module is not operating properly.
-  This symbol on the module indicates that an operator should refer to an explanation in the instruction sheet.
- Follow accepted safety procedures for the systems on which pressure or vacuum measurements are being made.

Materials Compatibility

The PV350 is compatible with industrial gases and liquids that are compatible with 316 stainless steel. To determine the compatibility of a liquid or gas, refer to the manufacturer's specifications. When making measurements on more than one type of pressure system, make sure the fluids or gases in those systems are compatible. If they are not, contamination or damage to the system being measured may result.

Cleaning

Clean the module using a soft cloth and mild soap and water. Do not immerse the PV350 in liquids.

Clean the transducer and connectors after each use with a cleaner appropriate for the liquid or gas connected during measurement. Refer to the manufacturer's instructions for the proper cleaning material.

Measuring Pressure and Vacuum

Caution

The sensor diaphragm can be damaged by solid or sharp objects. Never insert any object into the inlet port.

Clean the sensor immediately after use with appropriate solvents (refer to the solvent manufacturer's instructions).

Note

Fluke recommends that Teflon sealing tape (or its equivalent) be used in fitting threads to ensure good seals between the PV350 and any hoses or fittings.

1. Plug the PV350 into the DMM (red polarity dot to volts input) and set the multimeter to mV dc.
2. Check the battery voltage (see Testing the Battery).
3. Press the English/Metric button to select the desired units.
4. Slide the switch to the desired setting.
5. Before applying pressure, zero the module by turning the ZERO potentiometer until the DMM displays zero. (Zero on the range you will be using and rezero the DMM whenever the scale is changed.)

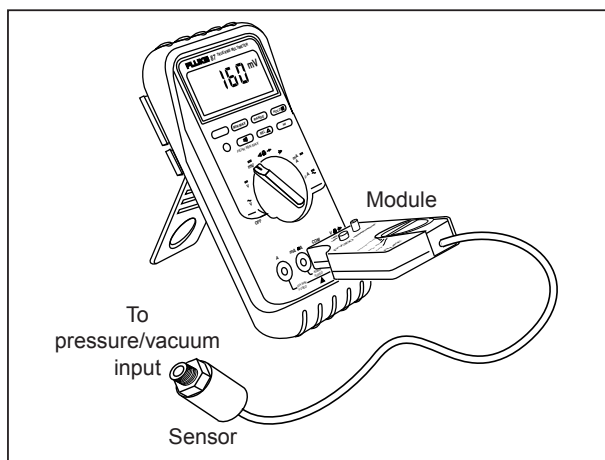

Figure 1. Operation

Note

The Relative or Zero function on your DMM (if available) can be used instead of the ZERO potentiometer to zero the meter. Refer to the multimeter's user manual for instructions on using this function. Zeroing the meter does not affect the module's specified accuracy.

6. Apply pressure/vacuum to the PV350 and read the DMM display.
 - When measuring pressure, if the DMM displays OL, switch the multimeter range from millivolts to dc volts. Increasing the range to dc volts moves the decimal position three places to the left (500 psi displays as 0.500 V).
 - When measuring vacuum the DMM displays a minus sign.

Testing the Battery

1. Turn the DMM and the module OFF and connect the PV350 to the DMM.
2. Turn the DMM on and set the DMM to the mV dc range.
3. If the DMM displays less than 100 mV, replace the battery.

How to Replace the Battery

⚠⚠ Warning

To avoid electrical shock, disconnect the module from all devices before opening the case. Be sure to completely reassemble the module before attempting to use it.

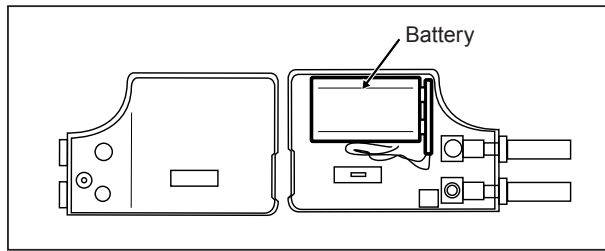

Figure 2. Battery Replacement

1. Turn the module OFF and unplug it from the DMM.
2. Remove the screw from the back of the module, separate the case, and replace the battery.
3. To reassemble, line up the holes in the case with the METRIC/ENGLISH switch and zero knob. Then snap the two halves together. Reinstall the screw.

Typical Applications

Refer to Figures 3 and 4 for typical applications.

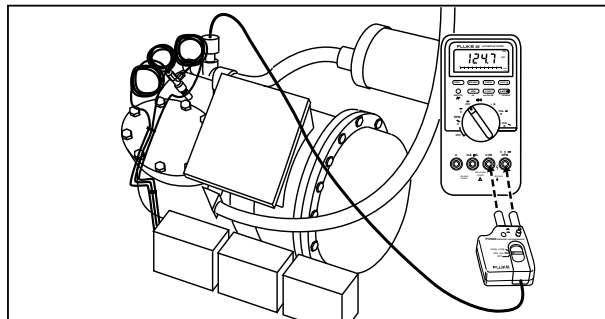

Figure 3. Pressure for HVAC/R Super Heat Measurements

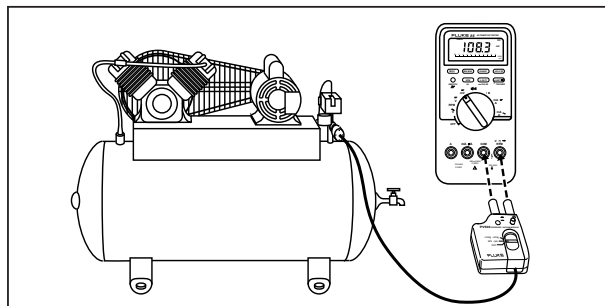

Figure 4. Measure Pneumatic Pressures

Conversion Factors

psi = inches of H ₂ O x (3.6127 x 10 ⁻²)	inches of H ₂ O = psi x 27.68
psi = mm of H ₂ O x (1.4223 x 10 ⁻³)	mm of H ₂ O = psi x 703.1
psi = cm of H ₂ O x (14.223 x 10 ⁻³)	cm of H ₂ O = psi x 70.3
psi = bar x (14.503)	bar = psi x 0.0689
psi = lbs/ft ² x (6.9444 x 10 ⁻³)	lbs/ft ² = psi x 144
psi = mbar x (1.4503 x 10 ⁻²)	mbar = psi x (68.9513)
psi = Pascals x (1.4503 x 10 ⁻⁴)	Pascals = psi x (6.895 x 10 ³)
All H ₂ O conversion factors are @ 4°C	

Specifications

The following specifications apply at 23 ±5 °C for 1 year after calibration when the module is zeroed prior to each measurement.

Pressure

Range	Accuracy
0 psi to 500 psi: (0 kPa to 3447 kPa)	±0.25 % of reading ±0.3 psi ±0.25 % of reading ±2.1 kPa)

Vacuum

Range	Accuracy
0 in-Hg to -29 in-Hg (0 cm-Hg to -76 cm-Hg)	±0.25 % of reading ±0.5 in-Hg (±0.25 % of reading ±1.3 cm-Hg)

Temperature coefficient: Add 0.05 % of reading per °C for temperature ranges -10 °C to 18 °C and 28 °C to 55 °C.

Output: 1 mV per unit (psi, kPa, cm-Hg or in-Hg)

Resolution: Determined by the resolution of the measuring device.

RFI Specification: Typically <1 % error from 80 to 200 MHz at 3 V/m.

Electromagnetic Compatibility (EMC)

International IEC 61326-1: Portable; IEC 61326-2-2; CISPR 11: Group 1, Class A

Group 1: Equipment has intentionally generated and/or uses conductively-coupled radio frequency energy that is necessary for the internal function of the equipment itself.

Class A: Equipment is suitable for use in all establishments other than domestic and those directly connected to a low-voltage power supply network that supplies buildings used for domestic purposes.

Korea (KCC) Class A Equipment (Industrial Broadcasting & Communication Equipment)

Class A: Equipment meets requirements for industrial electromagnetic wave equipment and the seller or user should take notice of it. This equipment is intended for use in business environments and not to be used in homes.

USA (FCC) 47 CFR 15 subpart B. This product is considered an exempt device per clause 15.103.

Meter Input Impedance: ≥1 MΩ

Maximum working pressure: 500 psi

Burst Pressure: 1000 psi

PV350 English Instruction Sheet
Page 6

Storage Temperature: -40 °C to 71 °C (Battery removed)

Operating Environment

Temperature	Humidity
-10 °C to 10 °C	Non-condensing
10 °C to 30 °C	0 °C to 95 % Relative Humidity
30 °C to 40 °C	0 °C to 75 % Relative Humidity
40 °C to 50 °C	0 °C to 45 % Relative Humidity
50 °C to 55 °C	0 °C to 35 % Relative Humidity

General

Weight: 12 oz, (336 grams)

Battery: Standard 9 V Alkaline battery (NEDA #1604, IEC 6LR61)

Battery Life: 300 hours (typical)

Electrical Cable: Black PVC, will withstand up to 105 °C

Cable Length: 8 ft

Pressure Port Connection: 1/4 in. NPT

Connector: Brass 1/4 in. male flare to 1/4 in. female pipe thread

List of Replaceable Parts

Part Number	Description
614487	Battery, Primary, 9 V, 0-15 mA
2813197	Case Bottom, PV350
2816172	Case Top, PV350
913207	Fitting, BR, SAE, 45, 1/4 FP
926873	PV350 Instruction Sheet
926881	PV350 Quick Reference Guide