

NAVAC

Empowering you to work smarter

Smart Refrigerant Charging Machine

NRC62D

User Manual



Failure to follow warnings could result in death or serious injury.

**SAVE THIS MANUAL
FOR FUTURE REFERENCE**

CONTENTS

TECHNICAL SPECIFICATIONS	01
SAFETY PRECAUTIONS	01
WORKING PRINCIPLES AND APPLICATION	02
CONNECTING TO THE EQUIPMENT	03
MACHINE PARTS AND FUNCTIONS	03
INSPECTIONS BEFORE OPERATION	06
OPERATION PROCEDURES	06
ROUTINE USE AND MAINTENANCE	08
SPECIAL MAINTENANCE OPERATION	10
EXPLODED VIEW	12
REPAIR PARTS LIST	13
TROUBLESHOOTING	14

1. TECHNICAL SPECIFICATIONS

Compatible Refrigerants	R11, R12, R13, R22, R23, R32, R113, R114, R123, R124, R134a, R290, R401A, R401B, R402A, R402B, R404A, R406A, R407A, R407C, R408A, R409A, R410A, R413A, R414B, R416a, R417A, R420A, R422A, R422B, R422D, R424A, R426A, R427A, R428A, R434A, R437A, R442A, R448A, R449AR450A, R452A, R454B, R502, R507A, R508B, R513A, R600a, R728, R744, R1234yf
Power Supply	115V / 60Hz
Evacuation Rate	6 CFM
Charging Rate	4 lbs/min
Motor Power	1/3 HP
Current	3.2A
Operating Temperature	30-104°F
Dimension	19.7" x 10" x 14.5"
Weight	39 Lbs

2. SAFETY PRECAUTIONS

Safety Instructions

1. This evacuation and charging machine designed for use **only** by trained HVACR professionals, and can be damaged or dangerous if operated **incorrectly**.
2. For your safety and correct operation, **please** read the operation manual **carefully** before use.
3. Never connect vcharging machine to a pressurized system, and **always** verify system is at atmospheric pressure or **below** before connecting hoses to an HVACR system.
4. Protective gloves and goggles should be worn during operation in case refrigerant gas or liquid comes in contact with skin or eyes.
5. Do not smoke while operating evacuation or charging equipment.
6. Do not use machine near **flammable** gases, open flames, or other ignition source.
7. **Please** do not use equipment in direct sun or in rain, cover if needed, leaving adequate room for ventilation.
8. **Always** make sure the equipment has good ventilation.

Precautions:

1. The smart refrigerant charging machine is for use with air conditioning and refrigeration systems **only**.
2. The red **high-pressure** hose is connected to the high pressure (liquid) valve on A/C-R systems and **blue** low pressure hose to the low-pressure (suction) valve.
3. Before operation, verify the type of refrigerant used to insure compatibility.

4. Charge cooling systems with the correct type of refrigerant and correct weight recommended by the manufacturer and calculated for associated piping.
5. Verify that power supply is 115V to the charging machine before powering on. Make sure the power supply is grounded.
6. Make sure all valves in the refrigerant charging machine are in the OFF position before connecting hoses to the system to be evacuated and charged.
7. Keep process hoses away from all moving parts, and any excessive heat in the system.
8. Check the oil level and condition in the charging machine before operation, change oil if needed.
9. Please do not alter the position of switch valve on refrigerant storage tank.
10. Only certified refrigerant tanks can be used.
11. Do not use vacuum pump oil in air conditioning systems, or refrigeration oil in vacuum pumps.
12. Keep high/low-pressure stop valves in the OFF position when the machine is not used. Protective caps should be kept on the high-pressure, low-pressure, and refrigerant inlet port connectors to prevent moisture, dirt, and air from entering the charging equipment that may adversely affect performance and service life.
13. Power extension cords should be no more than 75 feet long to prevent voltage drop.
14. Always follow safety precautions while moving and handling refrigerant storage tanks. Although refrigerant is non-toxic, odorless, non-corrosive and non-flammable, technicians must avoid inhalation of high-concentrations of vapor which displaces air, causing oxygen deprivation. Avoid skin contact with liquid refrigerant which may cause frostbite. Avoid phosgene gas, an acidic vapor formed by decomposition of refrigerant burned by open flame.

Note:

1. There may be a small amount of oil mist spraying from the oil fill port at the beginning of equipment evacuation. This is normal. The oil mist will become less with time goes on, until it disappears.
2. In the process of evacuation, the vacuum display will be temporarily disabled, if it comes in contact with trace amounts of refrigerant, and it will automatically return to normal display after the refrigerant has been evacuated.

Precautions at operation and use of refrigerant

Under the normal circumstances, refrigerant is a pressurized liquid. For ease of use and transportation, it is stored in a certified cylinder. Special attention should be paid during use. The technician should avoid inhalation of highly concentrated gaseous refrigerant, even in a very short time, because inhalation of the vapor may cause loss of consciousness or death. Wear the protective gloves and goggles during use to prevent liquid from contacting skin and eyes in case of release.

3. WORKING PRINCIPLES AND APPLICATION

1. NRC62D Smart Refrigerant Charging Machine is a precision multi-function piece of equipment, used to evacuate and precisely charge air-conditioning and refrigeration systems. It consists of a vacuum pump, a leak detection system, and programmable charging machine with scale. After simple programming, the machine first evacuates and leak tests the system to be charged, and then charges the pre-programmed amount of refrigerant, and finally pressure tests the system.
2. The entire process offers convenience, safety, energy savings, accuracy, and environmental protection. The charging machine is used while installing or servicing a wide variety of air conditioning and refrigeration equipment, from ductless split units to commercial package and split systems.
3. The automated charging machine has a memory function so that should a power failure occur, the isolation valves close, the program is saved, and you can resume operation by restarting the system by simply pressing the start button.

4. CONNECTING TO THE EQUIPMENT

Install the high-pressure (red) and low-pressure (blue) hoses as shown to connect to air conditioning or refrigeration system. The red hose is connected to the "HP (high pressure)" connection on the charging machine, and the blue to the "LP (low pressure)" connection. The inlet port of refrigerant is connected to the refrigerant cylinder. Purging the hose while making the connection to the charging machine. Be sure to position the cylinder in the proper orientation for charging, per the instructions from the manufacturer. Also note that a refrigeration manifold is NOT used for this operation, as internal solenoid valves isolate the system once all functions are concluded.

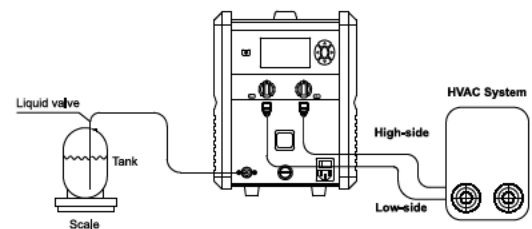

5. MACHINE PARTS AND FUNCTIONS

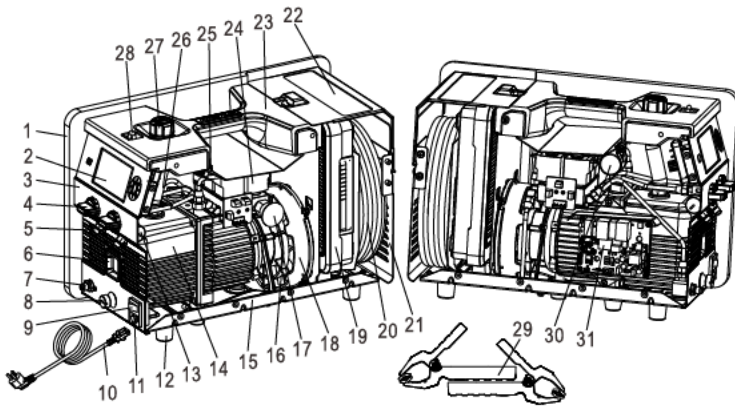

- | | |
|-------------------------------------|-------------------------------------|
| 1. Housing | 17. Vacuum Sensor |
| 2. Control Panel | 18. Wind Scooper |
| 3. Front Plate | 19. Wireless Electronic Scale |
| 4. High/Low-Pressure Stop Valve | 20. Refrigerant Hoses |
| 5. High/Low-Pressure Hose Connector | 21. Back Panel |
| 6. Oil Level Window | 22. Rotation Cover |
| 7. Refrigerant Inlet Port | 23. Handle |
| 8. Vacuum Pump Oil Drain | 24. Solenoid Valve Assembly |
| 9. Power Switch | 25. USB Port |
| 10. Power Cable | 26. Oil Filling Conduit |
| 11. Power Socket | 27. Filler Cap |
| 12. Rubber Feet | 28. Strap Bending Pin |
| 13. Pressure Sensor | 29. High and Low Temperature Probes |
| 14. Vacuum Pump | 30. Start Capacitor |
| 15. Baseplate | 31. DC Motor Control |
| 16. Fan | |

Display on control panel

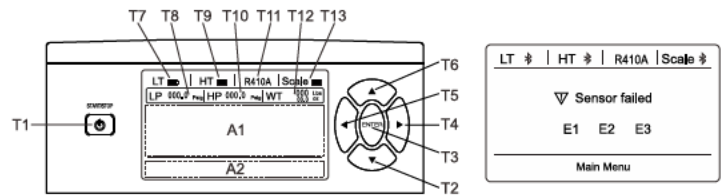

Digital display area

- A1: Main display area
A2: Current procedure

Status and Warning

- E1: High temperature probe error
E2: Low temperature probe error
E3: Vacuum sensor error

⚠ If these errors occur, contact our dealer or technical support.

Function button and indication

- T1: Start/Stop button: Press to start or stop. Hold 3 seconds to return to main menu.
T2: Press to go to the down option. In setting the figures, press to decrease the value.
T3: Confirm to operate.
T4: Press to go to the right option.
T5: Press to go to the left option. Hold 3 seconds to return to parameter setup.
T6: Press to go to the up option. In setting the figures, press to increase the value.
T7: Low temperature probe and its battery signals. Bluetooth signal shows if it is not connected.
T8: LP reading
T9: High temperature probe and its battery signals. Bluetooth signal shows if it is not connected.
T10: HP reading
T11: Current refrigerant
T12: Weight reading
T13: Scale and its battery signals, Bluetooth signal shows if it is not connected.



6. INSPECTIONS BEFORE OPERATION

1. Open the carton
Open it after checking the external carton. Please read the user manual carefully at least one time and keep the documents and accessories in their proper place.
2. Check work area for unsafe conditions, such as open heat source or fire source in the area.
3. Check oil level and condition in vacuum pump, making sure the oil level is in the middle; otherwise, change oil as described in the routine maintenance section.
4. Check valves
Verify the high/low-pressure valves and fill valve are closed, and all system switches are OFF.
5. Open the back cover at the rear of the charging machine and take out the wireless electronic scale. Put it onto flat dry ground and turn on the scale.
6. Verify that refrigerant used in the system is the same as that in the refrigerant cylinder.
7. Take out hoses and power cable from the case at the rear of the charging machine.
8. Verify 115V power source, then turn on power supply switch.
9. Connection
Connect one end of the blue hose to "LP (low pressure)" connection on the charging machine and the other end with the suction line on the equipment. Connect one end of the red hose with "HP (high pressure)" connection on the charging machine and the other end with the liquid line connection on the equipment. Connect one end of another refrigeration hose (yellow) to the valve on the refrigerant cylinder and the other end to the refrigerant fill port of the equipment.

Note:

The system can be evacuated by a single hose connection. In this case, either red or blue hose connection will work.

7. OPERATION PROCEDURES**7.1. Main Menu**

LT 	HT 	R410A	Scale 
Initial Setup			
Auto mode: Evacuation + Charging by Weight			
Manual mode: Evacuation			
Charging by Weight			
Charging by SC/SH			
System Monitor			
Purging			
Main Menu			

Initial Setup	Set up the refrigerant, pressure, vacuum, temperature, weight, target vacuum, sensor zero, bluetooth sync, etc.
Evacuation + Charging By Weight	Automatic evacuation, raising test, and charging.
Evacuation	Evacuate the system by setting the target vacuum.
Charging By Weight	Set the target weight and charge.
Charging By SH/CH	Manual charge by temperature.
System Monitoring	Display the SH/CH readings.
Purging	Purge the refrigerant within the machine.

8. ROUTINE USE AND MAINTENANCE

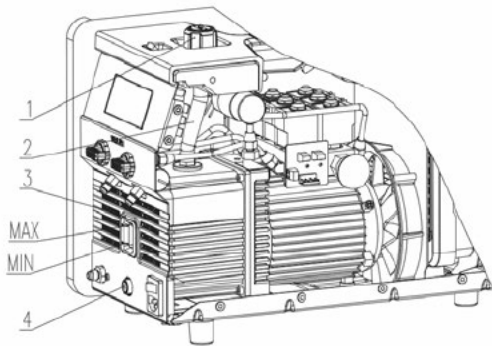
**Vacuum pump**

1. Vacuum pump oil has three major functions: pump lubricant, pump cooling, and pump sealant. During the evacuation process, the pump oil will absorb moisture being evacuated from the system, causing it to be less effective as a lubricant and pump vane seal, extending evacuation time and possibly causing the pump to overheat.
2. Only special purpose vacuum pump oil is to be used as required.

Note:

In order to properly check the oil level in the vacuum pump, run the vacuum pump for one minute and check oil level in the vacuum pump sight glass.

Adding Vacuum Pump Oil

When the oil level is lower than the MIN position in oil level window, vacuum pump oil must be added. Use the following procedure:

1. Disconnect the power plug to the charging machine.
2. Remove the oil fill cap and add vacuum pump oil to the inlet under the fill cap. Add oil a little at a time until the oil level reaches the middle position between MAX and MIN marks on the oil level window. Place back the oil fill cap and tighten.

Note:

When the pump runs, oil level must be between the upper and lower lines of MAX and MIN. Too low oil level will degrade performance of the pump, while too high oil level will cause a large quantity of oil mist to discharge from the oil fill port.

Replace vacuum pump oil

We recommend that the oil be changed just before evacuating each A/C-R system to insure the pump oil is in a clean condition as this is the key factor in determining if the pump can achieve the required vacuum levels. In order to maintain the optimum operation of the pump, we recommend that you use NAVAC vacuum pump oil. This oil is made using a unique process and can maintain proper viscosity during normal operation and temperatures, and it's also helpful for cold startup. Should the NAVAC oil not be available, reputable brands of special purpose vacuum pump oil may be used.

Note:

Should the pump oil become opaque, dirty, or full of moisture, promptly change oil.

1. Run vacuum pump for 1 minute to warm oil.
2. Disconnect power supply to the charging machine.
3. Remove oil fill cap and loosen the oil drain valve. Slant the pump body and remove the oil drain valve, draining used oil into an appropriate container and dispose of properly.
4. After draining oil, tighten the oil drain valve. Fill with new vacuum pump oil until the oil level reaches the line just below MAX. Tighten the oil filler cap. Run briefly (less than one minute) to verify proper oil level (between MIN and MAX) before use.



9. SPECIAL MAINTENANCE OPERATION

9.1.1 Wireless refrigerant scale



1. Connect power to the Charging Machine and turn on the power switch.
2. Open the rotating cover on the back of the machine and take out the wireless refrigerant scale and remove scale keypad; put it on a flat, dry, and stable surface.
3. Press the scale power switch for 1 second to turn on the wireless refrigerant scale, and press the power button of the scale keypad to turn it on.
4. Charging machine automatically connects with the scale by bluetooth.
5. Go to "Zero Scale" in "Initial Setup".
6. Press "YES" to zero.

9.1.2 Wireless refrigerant scale buttons



No.	Button	Function Description
1		Weight scale ON/OFF power button
2		Wireless sync bluetooth button

9.1.3 Process for synchronizing wireless communication

1. Make sure the scale is not weight loaded. Turn on the charging machine and scale. If the scale signal on charging machine and the blue indicator on scale flash, it means the sync does not succeed.
2. Go to "Initial Setup", "Bluetooth Sync", "Scale Bluetooth", "Sync". Press "ENTER" to sync.
3. If sync succeed within 1 minute, the bluetooth signal is on. If not, the signal is grey.

Note: for more scale operation, refer NAVAC NRS2i01 scale manual.

9.2.1 Temperature probe operation

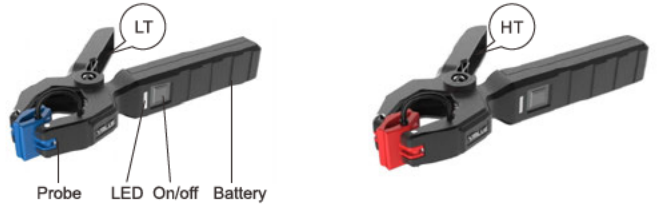

9.2.2 LED

Item	Status
Red flash	Low battery
Yellow flash	Not sync
Green flash	Sync

9.2.3 Probe parameter

Measuring range: -40~302 F
 Accuracy: ±1.3 F (-4 ~185 F)
 Resolution: 0.1 F
 Units: F, °C
 Operating temperature: -4~122 F
 Storage temperature: -4~140 F
 Auto shut-off when 5 minute of not sync
 Tube size: Φ6 ~ 1.4"
 Battery type: 3×AAA
 Battery life: > 400 hrs
 Bluetooth distance: ≥ 20 ft
 Dimensions: 7.2" × 4" × 1.1"

9.2.4

1. Turn on charging machine and go to main menu.
2. Place batteries in probes.
3. Press power button 1s to turn on.
4. Auto sync between charging machine and probes. After successful sync, probe battery signals show on.

9.2.4 Process for synchronizing

1. Below re-sync operation for sync failure or new temperature probe.
2. When "HT", "LT" signals and probe yellow flash, it means not sync.
3. Go to "Main Menu", "Initial Setup", "High Temp Sensor Bluetooth/ Low Temp Sensor Bluetooth", "Sync". Press "ENTER" to operate.
4. If sync succeed within 1 minute, the bluetooth signal is on. If not, the signal is grey.

9.2.6

Item	Status
Red flash	Battery is close out.
Auto shut-off	Battery is out soon.
Yellow flash	Not sync.

When scale or temperature probes can not measure correctly due to personal improper drop or impact, return them to NAVAC dealer to repair or calibrate.

EXPLODED VIEW

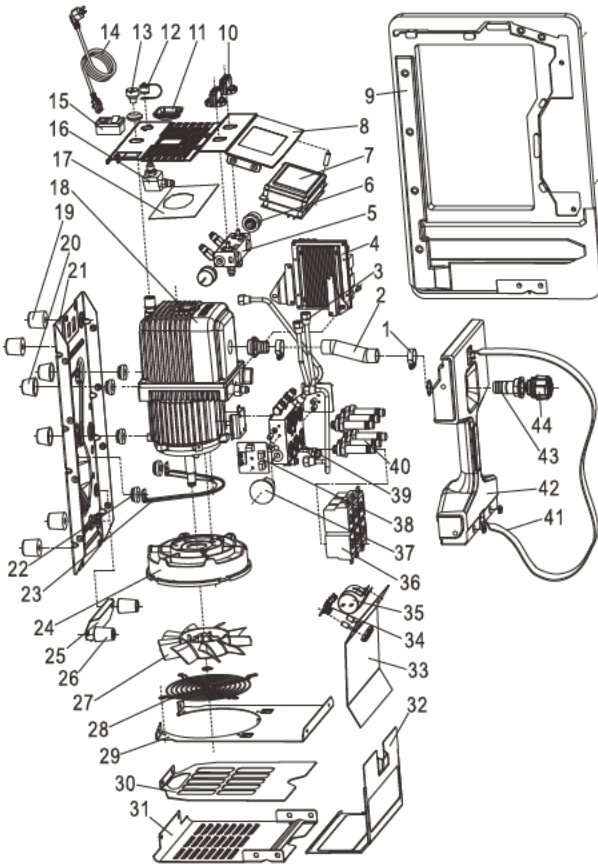

REPAIR PARTS LIST

Ref No.	Part No.	Description	Qty
1	CRP-1	Hoop	2
2	CRP-2	Oil Housing Conduit	1
3	CRP-3	Copper Pipes Assy	1
4	CRP-4	Driver	1
5	CRP-5	Check Valve Assy	1
6	CRP-6	Pressure Sensor Assy	2
7	CRP-7	Control Panel Assy	1
8	CRP-8	Front Plate Assy	1
9	CRP-9	Left/Right Shell	1
10	CRP-10	Knob	2
11	CRP-11	Oil Level Window	1
12	CRP-12	Valve Cap Assy	3
13	CRP-13	Oil Drain Cap	1
14	CRP-14	Power Cord	1
15	CRP-15	Power Socket	1
16	CRP-16	Non-Return Valve Assy	1
17	CRP-17	Dustproof Screen	1
18	CRP-18	Vacuum Pump	1
19	CRP-19	Rubber Feet I	4
20	CRP-20	Rubber Feet II	3
21	CRP-21	Base Plate Assy	1
22	CRP-22	Rubber Buffer	5
23	CRP-23	Valve Body	1
24	CRP-24	Wind Scooper	1
25	CRP-25	Iron Core Assy	1
26	CRP-26	Rubber Feet III	2
27	CRP-27	Fan	1
28	CRP-28	Fan Protection Net	1
29	CRP-29	Septum	1
30	CRP-30	Septum I	1
31	CRP-31	Back Board	1
32	CRP-32	Cover Board	1
33	CRP-33	Plate	1
34	CRP-34	Handle Assy	1
35	CRP-35	Starting Capacitor	1
36	CRP-36	Solenoid Valve Winding	6
37	CRP-37	Vacuum Sensor Assy	1
38	CRP-38	Solenoid Valve Connecting Plate	2
39	CRP-39	Valve Body Assy	1
40	CRP-40	Iron Core Assy	6
41	CRP-41	Strap	1
42	CRP-42	Handle Assy	1
43	CRP-43	Connecting Base	1
44	CRP-44	Exhaust Filter and Noise Reducer	1

