



Low-Profile Scales Ideal for General Shipping and Animal Weighing Applications

The Courier 5000 Series shipping scales feature a sturdy low-profile design with stainless steel top, making them tough enough for shipping applications, and easy to clean for small veterinary applications. Data is clearly legible on a large, bright 1.1 in/28 mm display, and UPS system communication protocol is included. Our proprietary Weight Alert™ mode will warn users if packages are too heavy, for example, to be sent by post or truck.

Unique Features:

- Easy-to-use scales for general shipping use with painted steel base. Stainless steel pan holds up to daily use and is easy to keep sanitary. Adjustable display for mounting to adapt to your workspace.
- The Dynamic Weighing/Display Hold application is ideal for large boxes and packages as it retains weight data on the display - also ideal for animals in veterinary use.
- AC adapter power included. Simple USB type C for data and power connection – includes UPS software protocol string. Can also run using disposable battery power.

COURIER™ 5000 Shipping Scales

Specifications

Model	i-C52M6R	i-C52M3OR	i-C52M50R	i-C52M50L	i-C52M100L	i-C52M200L	i-C52M200X
Capacity × Default Readability	6 kg x 0.002 kg 6,000 g x 2 g 12 lb x 0.005 lb 192 oz x 0.1 oz 12 lb x 0.1 oz	30 kg x 0.01 kg 30,000 g x 10 g 60 lb x 0.02 lb 960 oz x 0.5 oz 60 lb x 0.5 oz	50 kg x 0.02 kg 50,000 g x 20 g 100 lb x 0.05 lb 1,600 oz x 1 oz 100 lb x 1 oz		100 kg x 0.05 kg 200 lb x 0.1 lb 3,200 oz x 2 oz 200 lb x 2 oz		200 kg x 0.1 kg 400 lb x 0.2 lb 6,400 oz x 5 oz 400 lb x 5 oz
Maximum Displayed Resolution	1:3,000		1:2,500		1:2,000		
Weighing Units	kg, g, lb, oz, lb:oz (kg, lb, oz, lb:oz for models above 100 kg)						
Application Mode	Weighing, Dynamic Weighing/Display Hold, Totalization, Weight Alert™						
Display	1.1 in / 28 mm digit height, 5-digit, 7-segment LCD display with white backlight						
Keyboard	4 mechanical function keys						
Construction	ABS Plastic Indicator Housing Painted steel base with stainless steel platform (adjustable feet for L and X bases)						
Cable Length	6.6 ft / 2 m (full extension)						
Stabilization Time	1 second						
Power	Dry cell battery: 3 x AA (LR6) Batteries (not included) or AC Power Adapter: 100-240VAC ~ 0.5A 50/60Hz; Power output: 5.0 VDC 1.0 A or USB cable (USB connection to PC, cable length: 6.6 ft / 2 m) Battery life: 100 hours continuous use with backlight off						
Zero Range	2% or 100% of capacity						
Interface	Standard USB Type-C						
Operating Temperature Range	14 °F to 104 °F / -10 °C to 40 °C						
Safe Overload Capacity	150% of capacity						
Platform Dimensions (L x W x H)	13.0 x 12.6 x 1.7 in / 329 x 319 x 43.5 mm			20.5 x 15.7 x 2.1 in / 520 x 400 x 52.9 mm			35.4 x 23.6 x 2.0 in / 900 x 600 x 50.9 mm
Net Weight	9 lb / 4.1 kg			18.7 lb / 8.5 kg			38.4 lb / 17.4 kg
Shipping Weight	10.6 lb / 4.8 kg			21 lb / 9.5 kg			42.3 lb / 19.2 kg
Shipping Dimensions	15.6 x 15.2 x 6.1 in / 395 x 385 x 155 mm			23.6 x 19.1 x 3.9 in / 600 x 485 x 100 mm			38.8 x 26.8 x 4.1 in / 985 x 680 x 105 mm

Outline Dimensions

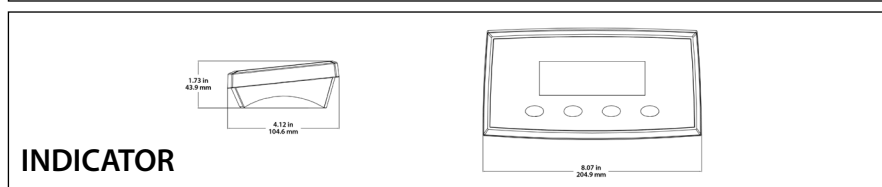
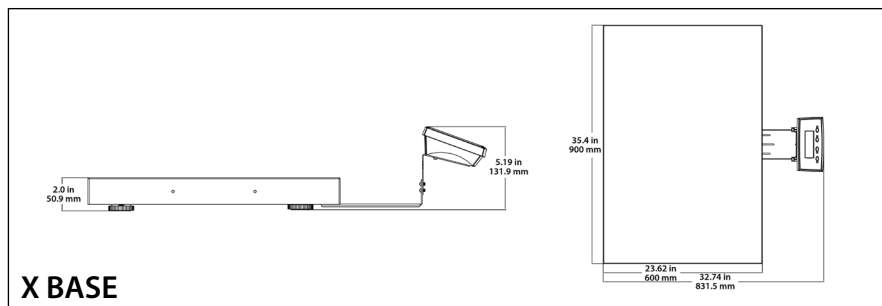
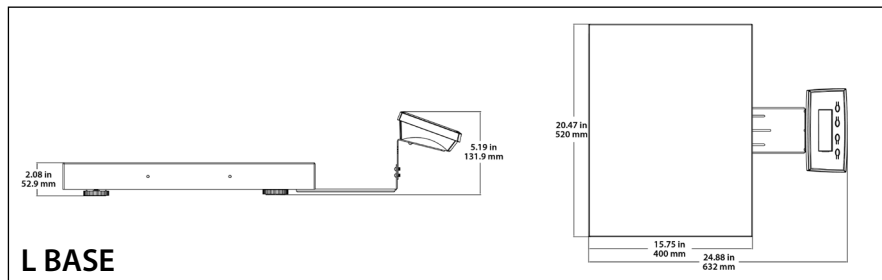
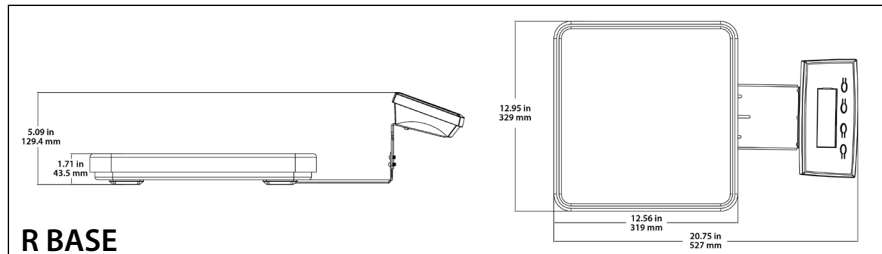

Compliance

- **Product Safety:** IEC/EN 61010-1; UL certified power supply
- **Electromagnetic Compatibility:** FCC Part 15 Class A; Canada ICES-003 Class A; IEC/EN 61326-1 Class B, basic environments
- **Compliance Marks:** CE
- **Other:** WEEE, RoHS

Accessories

Remote Column Kit 38.6 in / 980 mm Painted Steel
30795819

Remote Column Kit 13 in / 330 mm Painted Steel
30800931

Coiled Extension Cable 9m i-C52 i-C31
30809920

Rubber Mat Kit Antiskid for X base
30548975

80776844_A 20230609 © Copyright OHAUS Corporation

