

Declaration of Conformity

INSTRUMENT CO.,

GOM-801H

are with confirmed to comply with the requirements set out in the Council Directive on the approximation of the Law of Member States relating to Electromagnetic Compatibility (93/36/EEC, 92/31/EEC, 93/68/EEC) and Low Voltage Equipment Directive (93/36/EEC, 93/68/EEC).
 The evaluation regarding the Electromagnetic Compatibility and Low Voltage Equipment Directive, the following standards were applied:

| | |
|---|---|
| EMC | |
| EN 61326-1: Electrical equipment for measurement, control and laboratory use — EMC requirements (1997+A1: 1998 +A2:2001+A3:2003) | |
| Conducted and Radiated Emission EN 55011: 1998+A1:1999 + A2:2002 Class B | Electrostatic Discharge IEC 61000-4-2: 2001 |
| Conducted Harmonic EN 61000-3-2: 2000 | Radiated Immunity IEC 61000-4-3: 2002+A1:2002 |
| Voltage Fluctuation EN 61000-3-3: 1995+A1:2001 | Electrical Fast Transients IEC 61000-4-4: 1995+A1:2001+A2:2001 |
| ----- | Surge Immunity IEC 61000-4-5: 2001 |
| ----- | Conducted Susceptibility IEC 61000-4-6: 2001 |
| ----- | Power Frequency Magnetic Field IEC 61000-4-8: 2001 |
| ----- | Voltage Dips/ Interrupts IEC 61000-4-11: 2004 |

| |
|---|
| Safety |
| Low Voltage Equipment Directive 73/23/EEC & amended by 93/68/EEC |
| EN 61010-1: 2001 |

| CONTENTS | PAGE |
|--|-----------|
| 1. PRODUCT INTRODUCTION | 1 |
| 2. SPECIFICATIONS | 2 |
| 3. PRECAUTIONS BEFORE OPERATION | 4 |
| 3-1. UNPACKING THE INSTRUMENT | 4 |
| 3-2. LINE VOLTAGE | 4 |
| 4. PANEL INTRODUCTION..... | 5 |
| 5. CIRCUIT DESCRIPTION | 7 |
| 6. OPERATION INTRODUCTION | 9 |
| 6-1. PRELIMINARY OPERATION..... | 9 |
| 6-2. MEASUREMENT OF RESISTOR | 9 |
| 6-3. MEASUREMENT OF SWITCH..... | 10 |
| 7. MAINTENANCE..... | 11 |
| 7-1. LINE FUSE REPLACEMENT | 11 |
| 7-2. CLEANING..... | 11 |

SAFETY TERMS AND SYMBOLS

These terms may appear in this manual or on the product:



WARNING. Warning statements identify condition or practices that could result in injury or loss of life.



CAUTION. Caution statements identify conditions or practices that could result in damage to this product or other property.



WARNING: This equipment is not for measurements performed for CAT II, III and IV.

The following symbols may appear in this manual or on the product:



DANGER
High Voltage



ATTENTION
refer to Manual



**Protective
Conductor
Terminal**



**Earth(ground)
Terminal**

FOR UNITED KINGDOM ONLY

NOTE: This lead/appliance must only be wired by competent persons

WARNING: THIS APPLIANCE MUST BE EARTHED

IMPORTANT: The wires in this lead are colored in accordance with the following code:

| | |
|----------------|--------------|
| Green/ Yellow: | Earth |
| Blue: | Neutral |
| Brown: | Live (Phase) |

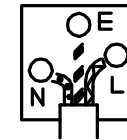

As the colors of the wires in main leads may not correspond with the colors marking identified in your plug/appliance, proceed as follows:

The wire which is colored Green & Yellow must be connected to the Earth terminal marked with the letter E or by the earth symbol  or colored Green or Green & Yellow.

The wire which is colored Blue must be connected to the terminal which is marked with the letter N or colored Blue or Black.

The wire which is colored Brown must be connected to the terminal marked with the letter L or P or colored Brown or Red.

If in doubt, consult the instructions provided with the equipment or contact the supplier.

This cable/appliance should be protected by a suitably rated and approved HBC mains fuse: refer to the rating information on the equipment and/or user instructions for details. As a guide, cable of 0.75mm² should be protected by a 3A or 5A fuse. Larger conductors would normally require 13A types, depending on the connection method used.

Any mounded mains connector that requires removal /replacement must be destroyed by removal of any fuse & fuse carrier and disposed of immediately, as a plug with bared wires is hazardous if a engaged in live socket. Any re-wiring must be carried out in accordance with the information detailed on this label.

1. PRODUCT INTRODUCTION

The Digital Milliohm Meter features with its accuracy and readability. The circuit of this instrument has equipped with the voltage regulator and temperature compensation in order for its accuracy not to be influenced by the unstable AC power source and the alternation of temperature.

The Digital Milliohm Meter is specially produced for the manufacturers of the low resistor, switch, relay, jacks, plugs, connectors sockets or the electrolytic capacitor for the QC or IQC purpose, it also can be applied to measure the initial contact resistance.

DM-801H DC MILLI-OHM METER

USER MANUAL

SPECIFICATIONS

specifications are operated under the essential conditions as follows:

A 1-year calibration cycle.

An operating temperature of 18 to 28°C (64.4 to 82.4°F).

Relative humidity not exceeding 80%.

Accuracy is expressed as \pm (percentage of reading + digits).

The instrument requires 30 minutes warm-up time to achieve rated accuracy.

| | | |
|---------------------------|--|-------------|
| Model | 3 1/2 Digital Panel Meter. | |
| Test Current | 10uA, 100uA, 1mA, 10mA, 0.1A, 1A Accuracy:0.2% | |
| Go/Lo Comparison Accuracy | 0.5% | |
| Test Ranges | 20, 200m Ω , 2, 20, 200 Ω , 2, 20k Ω totally 7 full scale ranges. | |
| Accuracy | \pm 0.2% rdg+4 digits(\pm 0.2% rdg+6 digits for 20m Ω range only) | |
| | Range | Current |
| | 20, 200m Ω | 1A |
| | 2 Ω | 0.1A |
| | 20 Ω | 10mA |
| | 200 Ω | 1mA |
| | 2k Ω | 100 μ A |
| | 20k Ω | 10 μ A |

GOM-801H DC MILLI-OHM METER

USER MANUAL

| | |
|------------------------------|---|
| Environment | |
| Operation Environment | Indoor use, altitude up to 2000m. Ambient Temperature 0°C to 40°C. Relative Humidity 80% (Maximum). Installation category II Pollution Degree 2 |
| Storage Temperature | -10°C to 70°C. |
| General | |
| Power source | AC 100V/120V/220V/230V \pm 10%, 50/60Hz, 25VA |
| Accessories | Test Lead \times 1, Instruction manual \times 1 |
| Dimension | 245(W) \times 95(H) \times 280(D) m/m |
| Weight | Approx. 2 kg |



WARNING : To avoid electrical shock, the power cord protective grounding conductor must be connected to ground.



CAUTION : To avoid damaging the instrument, do not use it in a place where ambient temperature exceeds 40°C .



CAUTION : The maximum input voltage on the testing terminal is limited at +10V DC. Besides, do not input the voltage reversely.

GOM-801H DC MILLI-OHM METER

USER MANUAL

PRECAUTIONS BEFORE OPERATION

Unpacking the Instrument

The product has been fully inspected and tested before shipping from the factory. Upon receiving the instrument, please unpack and inspect it to check if there is any damage caused during transportation. If any sign of damage is found, notify the bearer and/or the dealer immediately.

Line Voltage



WARNING. To avoid electrical shock the power cord protective grounding conductor must be connected to ground.

AVERISS: Pour éviter les chocs électriques, le fil de terre du cordon secteur doit impérativement être relié à la terre.

When line voltages are changed, replace the required fuses shown as below:

| Model | Line voltage | Range | Fuse | Line voltage | Range | Fuse |
|----------|--------------|----------|--------|--------------|----------|-------|
| GOM-801H | 100V | 90-110V | TT0.3A | 220V | 198-242V | T0.2A |
| | 120V | 108-132V | 250V | 230V | 216-250V | 250V |



WARNING. To avoid personal injury, disconnect the power cord before removing the fuse holder.

GOM-801H DC MILLI-OHM METER

USER MANUAL

4. PANEL INTRODUCTION

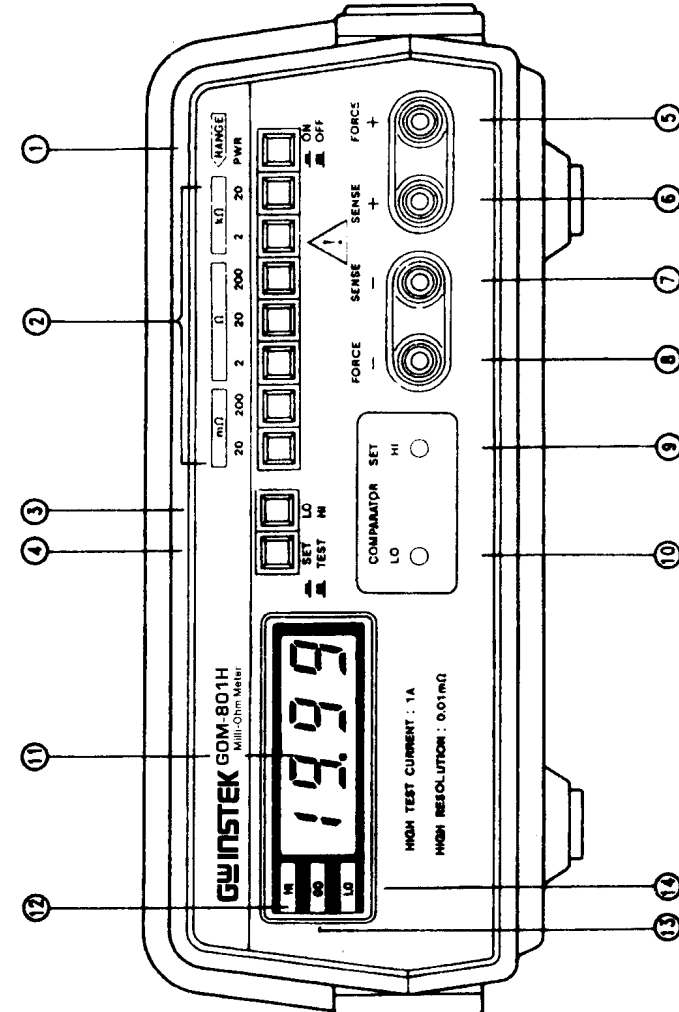

Figure 4-1. Front Panel

Front Panel

| | |
|----------------------|--|
| Power Switch | Power on/off switch. |
| Range | 7 steps: 20, 200mΩ, 2, 20, 200Ω, 2 and 20kΩ . |
| HI/LO | Set the “SET/TEST” switch to “SET” position, then select HI/LO for high or low value setting. |
| SET/TEST | This button can be used for testing or HI/LO value setting. |
| FORCE Terminal “+” | Test terminal. |
| SENSOR Terminal “+” | Test terminal. |
| SENSOR Terminal “-” | Test terminal. |
| FORCE Terminal “-” | Test terminal. |
| HI of Comparator Set | For high value setting. |
| LO of Comparator Set | For low value setting. |
| Panel Meter | To indicate the test value. |
| HI Indicator | This indicator will be lighted up when the test value is higher than the setting of high value. |
| GO Indicator | This indicator will be lighted up when the test value between high and low setting. The buzzer will be sounded up 2~5 seconds when the GO indicator is on. |
| LO Indicator | This indicator will be lighted up when the test value is lower than the setting of low value. |

5. CIRCUIT DESCRIPTION

- **DVM Circuit**

The DVM is an A/D converter by using IC U301.

- **10 or 100 Times Signal Amplifier**

The signal amplifier uses IC U401.

- **Test Range selected buttons**

There are 7 steps of Test ranges to be selected. It will not affect its accuracy due to the alternation or temperature.

- **Constant Current Source**

The circuit uses IC U201 and U202 and transistors Q203 and Q204 to produce constant current.

- **Comparator Set and HI, GO and LO Indicators**

The setting is consists of the resistors and the variable resistors. The comparator use IC U403 and U404. The HI, GO and LO indicators use transistors Q401~Q407.

- **Voltage Regulator Circuit**

The power supply has regulated output of $\pm 5V$ and $\pm 15V$ voltage, which are regulated by using Q201, Q202 and Q301 resistors to control D201, D202 and D301 zener diodes. The +5V voltage regulator circuit uses IC U302 voltage regulator.

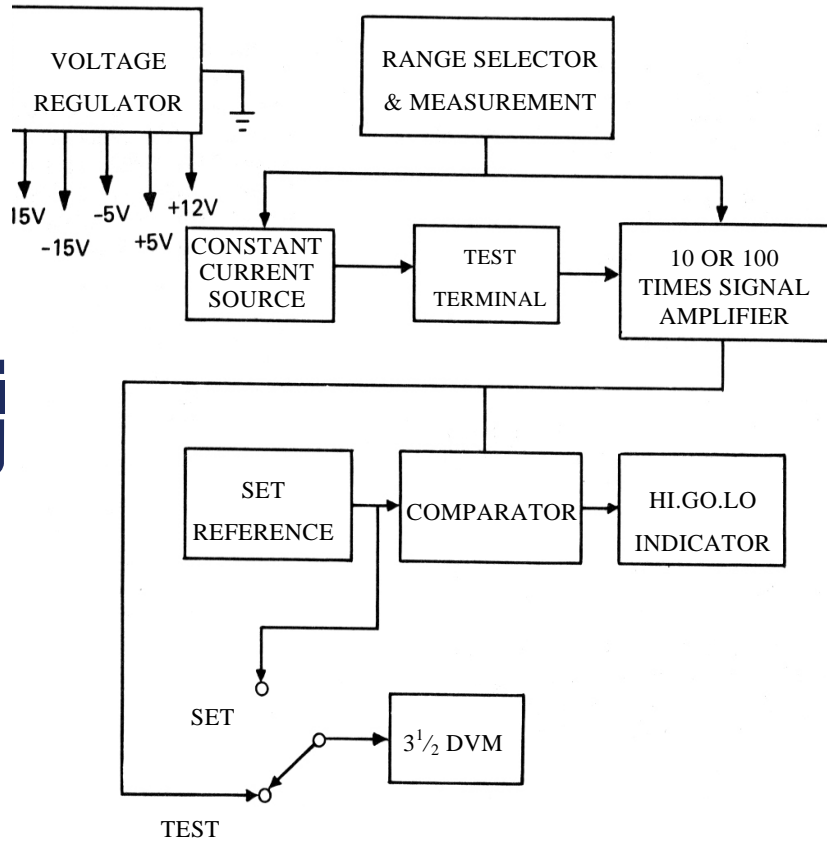

Fig. 5-1

6. OPERATION INTRODUCTION

6-1. Preliminary Operation

1. Set the power off.
2. Make sure that line voltage is correct for the input power voltage.
3. Plug power cord into the power outlet.
4. Turn on the instrument and allow about 10 minutes of warm up time to stabilize the instrument.

6-2. Measurement of Resistor

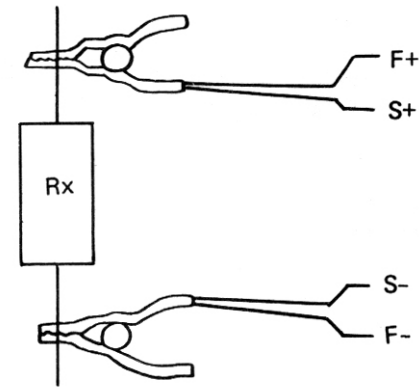
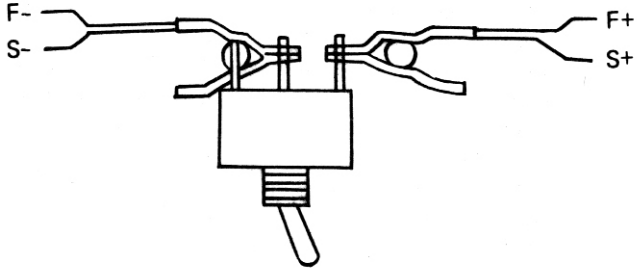

Fig. 6-1

1. Connect an unknown resistor to the test terminals as shown in Fig. 6-1.
2. Set the range to the position where the reading value can be obtained.

Measurement of Switch**Fig. 6-2**

1. Connect the switch to be tested as shown in Fig. 6-2.
2. Set the range to the position where the reading value can be obtained.

7. MAINTENANCE

Qualified personnel execute the following instructions only. To avoid electrical shock, do not perform any servicing other than the operating instructions unless you are qualified to do so.

7-1. Line fuse replacement

If the fuse blows, the meter would not work. Try to determine and correct the cause of the blown fuse, then replace the fuse with correct rating and type shown as below:

| FUSE RATING AND TYPE | |
|----------------------|--------|
| 100/120V | TT0.3A |
| 220/230V | T0.2A |



WARNING: For continued fire protection, replace only with 250V fuse of the specified type and rating, and disconnect the power cord before proceeding fuse replacement.

7-2. Cleaning

To keep the instrument clean, wipe the case with a damp cloth and detergent. Do not use abrasives or solvents.