

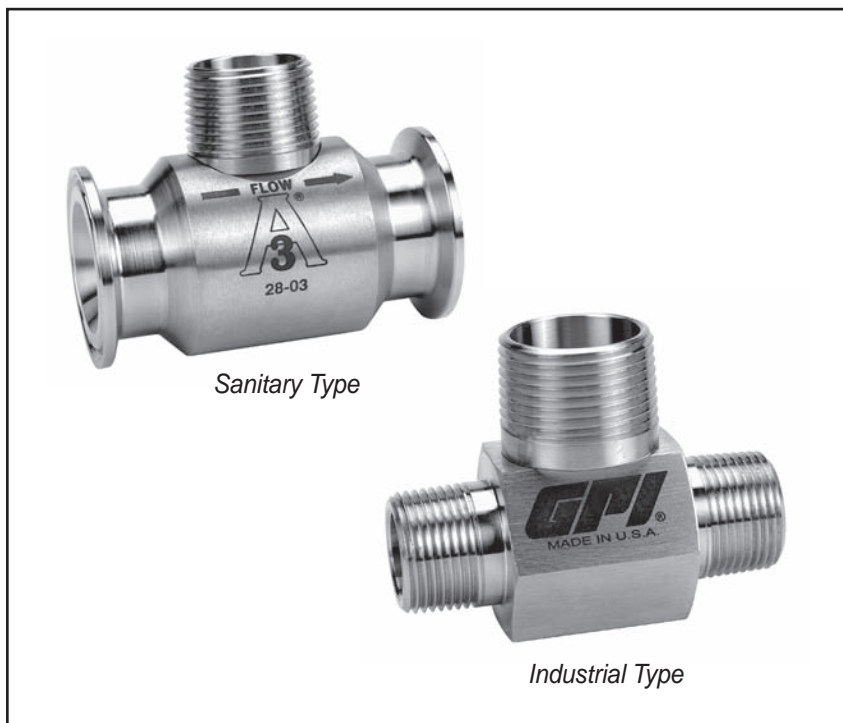

# G SERIES TURBINES

## Owner's Manual



03/13

Rev. D 921977-02

## TABLE OF CONTENTS

General Information.....	2
Installation .....	3
Maintenance .....	4
Troubleshooting.....	11
Specifications .....	12
Service.....	14

### To the owner...

Congratulations on receiving your GPI G Series Turbine. We are pleased to provide you with a product designed to give you maximum reliability and efficiency.

Our business is the design, manufacture, and marketing of liquid handling, agricultural, and recreational products. We succeed because we provide customers with innovative, reliable, safe, timely, and competitively-priced products. We pride ourselves in conducting our business with integrity and professionalism.

We are proud to provide you with a quality product and the support you need to obtain years of safe, dependable service.



Victor Lukic, President  
Great Plains Industries, Inc.

## GENERAL INFORMATION

This manual will assist you in installing and maintaining your GPI G Series Turbine. For best results, take the time to fully acquaint yourself with all information about all components of your G Series Turbine. If you need assistance, contact the distributor from whom you purchased your turbine.

2

## Product Description

GPI G Series Turbine flowmeters are volumetric flow measurement devices. The moving fluid is used to turn a rotor, which is suspended in the flow stream. The rotating speed of the rotor is proportional to the fluid velocity or flowrate. As the blades from a spinning rotor pass by a magnetic sensor, an AC voltage pulse is generated and transmitted to the readout instrument. Each pulse is equal to a given volume of liquid, therefore "x" number of pulses are equal to a gallon, litre, pound, barrel, etc.

## Turbine Sizing

GPI G Series Turbines are identified by the internal diameter of the inlet and outlet.

Model 050	½ inch (0.6-6.0 GPM)
Model 051	½ inch (0.8-6.0 GPM)
Model 075	¾ inch (1.6-16 GPM)
Model 075E	¾ inch (2.3-23 GPM)
Model 100	1 inch (6.7-67 GPM)
Model 150	1 ½ inch (17.7-177 GPM)
Model 200	2 inch (33-330 GPM)
Model 300	3 inch (60-600 GPM)

Turbine flowmeters should be sized in accordance to the actual flowrate and not the process pipe size. For example: a process having a flowrate of 10-20 GPM in a 1-½" process line requires either a Model 075E or Model 100 turbine flowmeter.

Another important factor to take into consideration when sizing a turbine flowmeter is instantaneous flowrate. This is extremely important when sizing a turbine flowmeter where the volume is measured per hour or per day. For example, an application where the total output is 500 barrels per day, occurring in a five hour period; the recommended turbine flowmeter should be sized according to the instantaneous flowrate:

$$(500 \div 5) \times 24 \text{ or } 2,400 \text{ barrels per day}$$

Thus, requiring an 1 ½ inch turbine flowmeter.

## INSTALLATION

Turbine flowmeters are affected by both upstream and downstream process configurations. Turbine flowmeters should always be installed with a minimum of 10 pipe diameters upstream and 5 pipe diameters downstream. The only exception is the placement of the pumps, valves, etc., on the upstream end. When this occurs, 20 diameters of straight pipe should be used. The direction of flow is indicated by the arrow on the turbine. All turbine flowmeters are designed to measure flow in only one direction.

Check the items that follow once the turbine flowmeter is installed in the process line. This will ensure a successful start-up.

1. Install magnetic pickup (Figure 1).
2. Make sure that the new or correct K-factor is entered into the readout device.

**NOTE:** The K-factor is printed on the turbine body. The calibration report included with the product provides several points along the flow curve.

### Initial Start-Up

Turbine flowmeters can be installed in the horizontal or vertical position. When installing a turbine flowmeter in the vertical position, it is important that the direction of flow be up through the turbine flowmeter.

A spool should be installed in place of the turbine flowmeter during initial start-up of a new process line. The process line should be purged, thus eliminating any solids contained in the line. Once this is completed, the spool can be removed and the turbine flowmeter installed.

**NOTE:** Control valves should always be installed downstream of the turbine flowmeter.

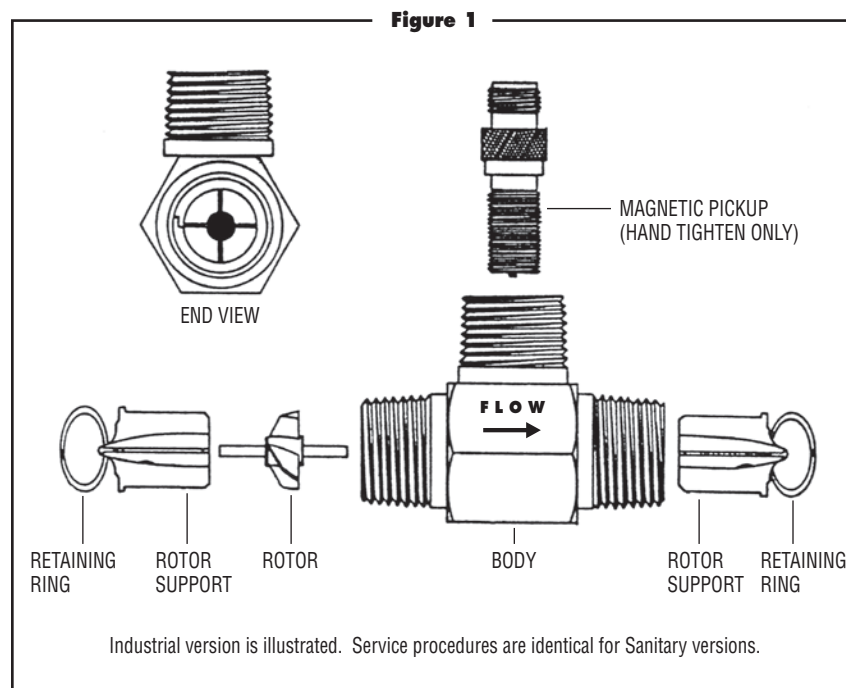

The turbine flowmeter should be installed in a location where the process line will remain full of liquid at all times. Otherwise, when the process line becomes empty and a valve is opened, the high velocity fluid hitting the turbine flowmeter rotor can cause severe damage.

When there is trapped air in the process line, an air eliminator should be used. This trapped air causes air pockets and these air pockets will cause the rotor to spin at a faster rate than liquid, thus resulting in incorrect readings, which results in an overstatement of actual flowrate and volume. This condition can damage the flowmeter.

**⚠ WARNING**

**If liquid being measured contains large solids, install a filter or strainer. Without the use of a filter or strainer, damage can occur to the internal components.**

In process lines where particulates are present, a filter/strainer should be used. Refer to the table below for the recommended mesh size.

Turbine Flowmeter Size	Mesh Size
½ inch	40
¾ inch	40
1 inch	40
1 ½ inch	18
2 inch	14
3 inch	14

## MAINTENANCE

### Cleaning Procedures

G Series Sanitary Turbines are designed to be compatible with commercially accepted methods of both CIP (Cleaned-In-Place) mechanical

cleaning as well as intermittent SIP (Steam-In-Place) cleaning methods.

If CIP or SIP cleaning methods are not available, manual COP (Cleaning-Out-of-Place) methods can be used.

Care must be taken during system start-up, chemical cleaning, air purge or steam cleaning processes to ensure that the turbine rotor does not over speed as damage can result to the rotor and/or bearing. Maximum allowable over range for G Series Turbines is 125% of maximum rated flowrate for intermittent periods.

A minimum fluid velocity of 5 foot per second (1.5 meter per second) must be maintained during the CIP process to ensure adequate cleaning.

**Reference:** 3-A Accepted Practices for Permanently Installed Product and Solution Pipelines and Cleaning Systems Used in Milk and Milk Product Processing Plants, Number 605-XX as amended for procedures and recommended flowrates.

The following flowrates are recommended by the 3-A Recommended Practices 605-XX to achieve 5 FPS or 1.5 MPS in the respective Sanitary Tube size:

SANITARY TUBE SIZE		Flowrate
O.D.	I.D.	
<b>INCHES</b>		
1.0	.875	9.4 GPM
1.5	1.375	24 GPM
2.0	1.875	43 GPM
<b>CENTIMETERS</b>		
2.5	2.22	35.6 LPM
3.8	3.50	90.8 LPM
5.1	4.75	163 LPM

Temperature limit for SIP cleaning is primarily limited by the temperature rating on the magnetic pickup. If the pickup temperature rating will be exceeded during SIP cleaning,

remove it during the cleaning process or a higher temperature rated pickup should be specified. Internal components of the G Series Sanitary Turbine must be limited to less than 285° F (140° C). The temperature and pressure rating of gaskets and clamps used in the installation must also be taken into consideration when determining cleaning parameters.

Minimum requirements for effective sterilization with SIP cleaning are to maintain 250° F (121° C) at the coldest point in the system for a minimum of 30 minutes. This requires a minimum of 15.3 psig (106 kPa) saturated steam pressure. Normal recommended maximums for SIP cleaning on G Series meters is 285° F (140° C) and 39 psig (269 kPa) saturated steam pressure.

### Disassembling the Turbine

1. Disconnect the turbine flowmeter cable from the magnetic pickup. Refer to Figure 1.
2. Remove the magnetic pickup.
3. Ensure that the process line is depressurized and empty prior to removal of the turbine flowmeter. Remove the turbine flowmeter from the process line.
4. Using a small screwdriver or similar tool, insert it into the radius notch of the retaining ring, pull away from the groove and up, removing the retaining ring from one end of the turbine flowmeter. This will allow the support to slide out of the turbine flowmeter body. Remove the rotor before proceeding to the other support.

**NOTE:** To remove the other support, simply repeat this operation.

5. Once the turbine flowmeter is taken apart, inspect the turbine flowmeter body for signs of wear or defects. The body bore should be smooth and show no evidence of wear.

**NOTE:** Do not install a new replacement kit into a turbine flowmeter body that shows significant signs of wear.

6. Examine the rotor for broken and/or bent blades. Remove any foreign matter.
7. Examine the supports for signs of deterioration, such as wear marks and/or burrs along the outer edge of the support vanes.
8. When the rotor or the supports show any sign of deterioration, a new replacement kit should be installed. Do not install a new replacement kit into a defective turbine flowmeter body.

### Replacement Kits

A replacement kit is comprised of all the internal component parts within the turbine flowmeter. A replacement kit consists of the following:

Parts Description	Quantity
Rotor Assembly	1
Support Assembly*	2
Retaining Ring	2

\* The support assemblies come complete with bushings and thrust balls, which are factory installed. Proper selection of bearing material is critical when ordering a new replacement kit.

GPI supports are identical in design, thus eliminating assembly error. Each support incorporates a thrust bearing, which allows for bidirectional flow and prevents damage to the rotor and/or supports in the event the turbine flowmeter is installed backwards with respect to the direction of flow.

Notice that the direction of flow is displayed on the body of the turbine flowmeter. This is important when installing the rotor and also denotes the direction in which the turbine flowmeter was calibrated.

**NOTE:** GPI rotors are tapered on one end (except 1/2" and 3/4"). The tapered end should be installed on the inlet side. See Figure 1. The 1/2" and 3/4" rotors are marked with a point on the hub and should be installed with the marked side of the rotor hub on the inlet side.

1. Install a support on the inlet side (where the flow starts), placing a vane between the notches in the turbine flowmeter body. Install a retaining ring – this will keep the support in place.
2. Place the rotor with the shaft in the support that has not been installed. Hold the turbine flowmeter body with the open end down and slide the rotor and support into the turbine flowmeter body. Make sure the vane is placed between the notches.

3. Once the support is in place, install the retaining ring.
4. Blow into the turbine flowmeter to ensure the rotor spins freely. Installation of the replacement kit is complete and the turbine flowmeter can be reinstalled into the process line.
5. Install the magnetic pickup. **HAND TIGHTEN ONLY.**

**NOTE:** Be sure to use the proper magnetic pickup, cable and connector for the application.

6. Enter the new K-factor supplied with the replacement kit into the electronic readout device. (Refer to the calibration report.)

**NOTE:** All internal replacement kits are factory calibrated and are supplied with a five point calibration report.

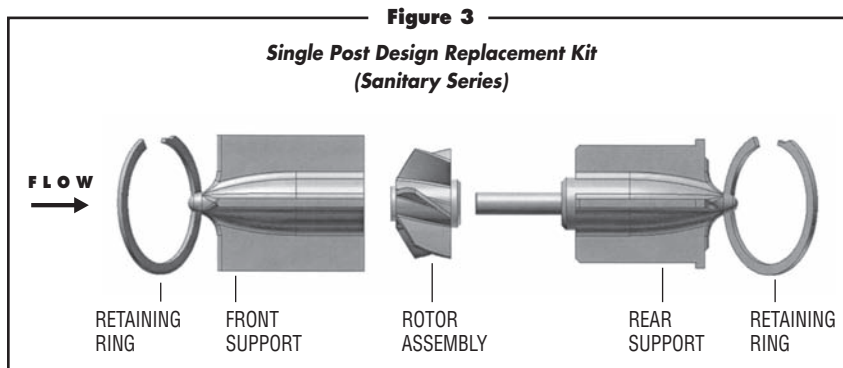
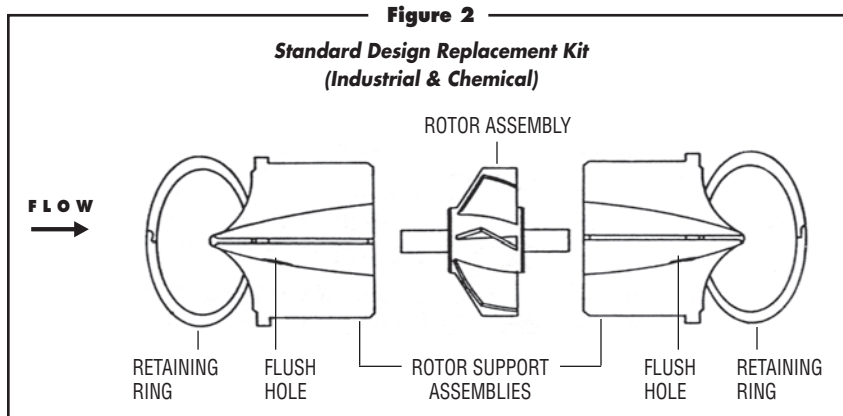

<b>Replacement Kits for Industrial Turbine Flowmeters</b>					
Size	Flow Range (Litres Per Minute)	Tungsten Carbide*		High Density Plastic*	
		Model	Part No.	Model	Part No.
½ in.	2.2-22 LPM			GNP-050 GSCP-050	80508032
½ in.	3.0-22 LPM	GNT-051 GFT-051	80518031	GNP-051 GSCP-051	80518032
		GNT-051H GFT-051H	80518081		
¾ in.	6-60 LPM	GNT-075 GFT-075	80758031	GNP-075 GSCP-075	80758032
		GNT-075H GFT-075H	80758081		
¾ in. E	8.7-87 LPM	GNT-075E GFT-075E	80768031	GNP-075E GSCP-075E	80768032
		GNT-75EH GFT-75EH	80768081		
1 in.	25.2-252 LPM	GNT-100 GFT-100	81008031	GNP-100 GSCP-100	81008032
		GNT-100H GFT-100H	81008081		
1 ½ in.	67-670 LPM	GNT-150 GFT-150	81508031	GNP-150 GSCP-150	81508032
		GNT-150H GFT-150H	81508081		
2 in.	125-1,250 LPM	GNT-200 GFT-200	82008031	GNP-200 GSCP-200	82008032
		GNT-200H GFT-200H	82008081		
3 in.	227-2,270 LPM	GNT-300 GFT-300	83008031		

\* Sleeve Bearing

<b>Replacement Kits for Sanitary Turbine Flowmeters (GSCPS)</b>			
Size	Flow Range (Gallons Per Minute)	Single Post	
		Model	Part No.
1 in.	6.7 - 67 GPM	GSCPS	81008074
1 ½ in.	17.7 - 177 GPM	GSCPS	81508074
2 in.	33 - 330	GSCPS	82008074

## Magnetic Pickups

GPI offers two types of magnetic pickups: Standard and Wire Lead. See Figure 4.

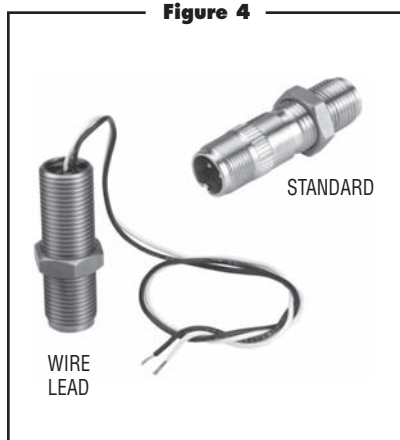

When choosing a magnetic pickup, the turbine meter and electronics are generally already known. Electronics can be either Local or Remote. Remote electronics include GPI Remote Displays or output to customer supplied equipment. Follow the next three steps when choosing a magnetic pickup.

1. Select your size: ½ in. or ¾ to 3 in.
2. Choose Local or Remote/Output. Local uses a wire lead pickup. Remote/Output requires a connector.
3. Choose either Sine Wave or Square Wave as your signal type. Sine Wave does not require external power for sensor and can be used with battery powered displays. Square Wave means sensor power is required.

<b>Selection Guide for ½ in. Turbine Meters</b>			
<b>Magnetic Pickup Type</b>	<b>Part No.</b>	<b>Application</b>	<b>Cable Type</b>
Wire Lead Low Drag	81006001	Use with Model 051. Meter mount electronics. Temperature range: -100° F to +250° F. Sine wave output.	None
Low Drag	81006000	Use with Model 051. Remote mount electronics. Temperature range: -450° F to +450° F. Sine wave output.	S
High Temp, Low Drag	81007001	Use with Model 051. Remote mount electronics. Temperature range: -450° F to +800° F. Sine wave output.	None
RF Digital	81005002	Use with Models 050 or 051. Temperature range: -40° F to +248° F. Square wave, open collector output. 7-30 VDC required.	D
<b>Selection Guide for ¾ in. to 3 in. Turbine Meters</b>			
Wire Lead Standard	81003000	Meter mount electronics. Temperature range: -100° F to +250° F. Sine wave output.	None
Standard	81001000	Remote mount electronics. Temperature range: -100° F to +250° F. Sine wave output.	S
Herm/High Temp.	81002000	Remote mount electronics. Temperature range: -450° F to +450° F. Sine wave output.	H or T
High Temp. Standard	81007000	Remote mount electronics. Temperature range: -450° F to +800° F. Sine wave output.	H or T
Active Digital	81004000	Remote mount electronics. Temperature range: -40° F to +248° F. Square wave, open collector output, 5-32 VDC required. Signal Output: 0-10 V, NPN.	D

### Magnetic Pickup Enclosures

Pickup Enclosures are optional on G Series Turbine Meters. Choose from three pickup enclosures: Model N4A

is the weatherproof enclosure. For explosion-proof enclosures, choose N7A for the enclosure without the terminal strip or the N7AT with the terminal strip. See Figure 5.

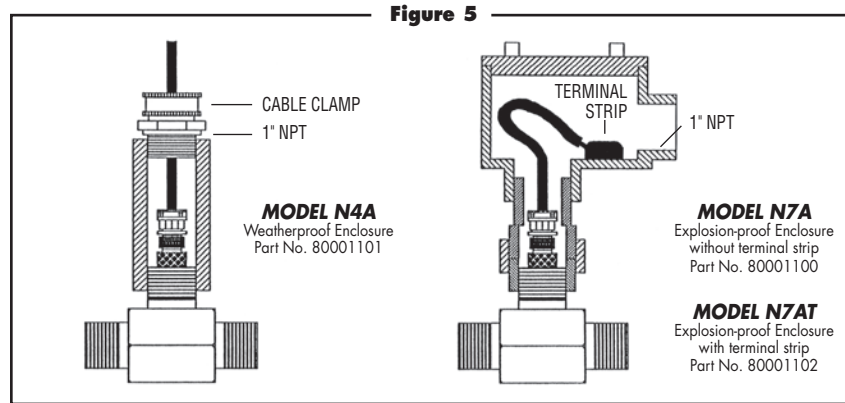

### Cable Assemblies

Cable Assemblies include the connector.

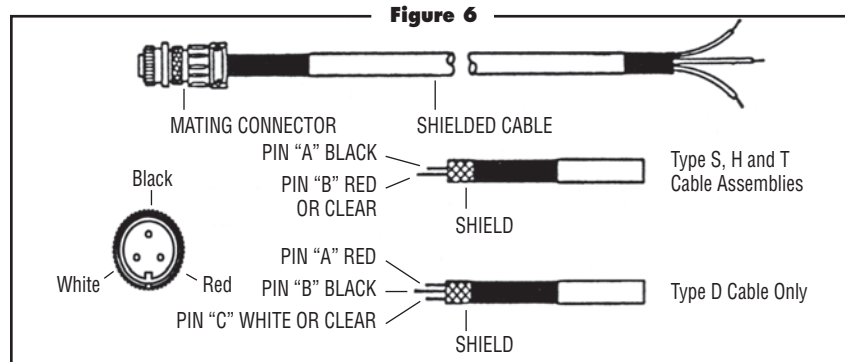

### Cable Length Selection Guide

Cable Length	Type "S" Standard (2 Conductor)	Type "D" Digital or RF (3 Conductor)	Type "H" Water Resistant (2 Conductor)	Type "T" Hi-Temperature (2 Conductor)
8 inch	83001001	83002001	83003001	83004001
5 feet	83001005	83002005	83003005	83004005
10 feet	83001010	83002010	83003010	83004010
15 feet	83001015	83002015	83003015	83004015
20 feet	83001020	83002020	83003020	83004020
25 feet	83001025	83002025	83003025	83004025
30 feet	83001030	83002030	83003030	83004030
40 feet	83001040	83002040	83003040	83004040
50 feet	83001050	83002050	83003050	83004050
75 feet	83001075	83002075	83003075	83004075
100 feet	83001100			
125 feet	83001125			

## FLOW RANGES

Size	Gallons Per Minute		Litres Per Minute		Frequency Output
	Min.	Max.	Min.	Max.	
½ in.	0.6	6.0	2.2	22	100 - 1000 Hz
½ in.	0.8	6.0	3.0	22	125 - 1000 Hz
¾ in.	1.6	16	6.0	60	100 - 1000 Hz
¾ in. E	2.3	23	8.7	87	100 - 1000 Hz
1 in.	6.7	67	25.2	252	100 - 1000 Hz
1 ½ in.	17.7	177	67.0	670	100 - 1000 Hz
2 in.	33	330	124.9	1249	100 - 1000 Hz
3 in.	60	600	227.1	2271	50 - 500 Hz

## DIMENSIONS

Size	NPT & Flared		Flanged		Sanitary Clamp		Tri-Clover Clamp	
	Height	Length	Height	Length	Height	Length	Height	Length
½ in.	2.562	2.750	—	—	—	—	2.562	2.750
½ in.	2.562	2.750	—	—	—	—	2.562	2.750
¾ in.	2.625	3.250	2.00	5.50	—	—	2.625	3.250
¾ in. E	2.625	3.250	2.00	5.50	—	—	2.625	3.250
1 in.	2.75	3.562	2.125	5.50	2.75	3.562	2.75	3.562
1 ½ in.	3.00	4.594	2.50	6.00	3.00	4.594	3.00	4.594
2 in.	3.25	6.063	3.00	6.50	3.25	6.063	3.25	6.063
3 in.	3.50	10.00	3.75	10.00	—	—	—	—

Dimensions are provided in inches.

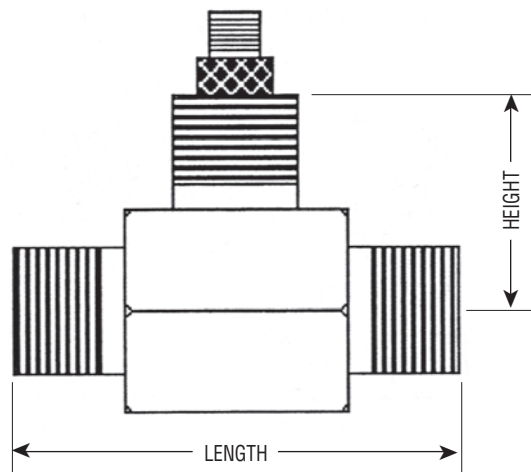

(For optional low profile models, subtract 1 inch from height.)

## TROUBLESHOOTING

Symptom	Probable Cause	Solution
A. MORE VOLUME/ OUTPUT THAN DISPLAYED OR REGISTERED	<ol style="list-style-type: none"> <li>1. Rotor may drag due to foreign matter obstruction.</li> <li>2. Magnetic pickup not screwed down all the way into the turbine flowmeter body. This causes it not to detect all the rotor blades as they pass.</li> <li>3. Turbine flowmeter installed backwards.</li> <li>4. Turbine flowmeter rotor installed backwards.</li> <li>5. K-factor is too high in electronic/readout device.</li> </ol>	<p>Check for debris inside the meter. Clean and reassemble.</p> <p>Screw the magnetic pickup all the way down into the turbine flowmeter body. Hand-tighten only.</p> <p>Install the turbine flowmeter in accordance with the process flow direction.</p> <p>Install the turbine flowmeter rotor in accordance with the process flow direction.</p> <p>Verify K-factor used. K-factor should be decreased.</p>
B. LESS VOLUME/ OUTPUT THAN DISPLAYED OR REGISTERED	<ol style="list-style-type: none"> <li>1. Caused by trapped air in the process line.</li> <li>2. K-factor is too low in electronic/readout device.</li> </ol>	<p>Install an air eliminator upstream of turbine flowmeter.</p> <p>Verify K-factor used. K-factor should be increased.</p>

## SPECIFICATIONS

**Accuracy\*:**  $\pm 0.5\%$  of the true flow at any point within the linear range of the turbine flowmeter.

**Linearity\*:**  $\pm 0.5\%$  of the mean K-factor throughout the linear range.

**Repeatability\*:**  $\pm 0.1\%$  of the indicated flow throughout the linear range.

**Response Time:**  
**½ in. to 2 in.:** 2-5 milliseconds for step change in flowrate.  
**3 in.:** 10-25 milliseconds for step change in flowrate.

**Frequency Output:**  
 (over the linear range)  
**½ in. (051):** 125 - 1000 Hz  
**½ in. to 2 in.:** 100 - 1000 Hz  
**3 in.:** 50 - 500 Hz

**Voltage Output:**  
**½ in. to 2 in.:** Approx. 100 mV @ 100 Hz to 1.0-volt (r.m.s.) @ 1000 Hz  
**3 in.:** Approx. 80 mV @ 50 Hz to 800 mV (r.m.s.) @ 500 Hz

**Maximum Overrange:** to 125% of maximum flowrate for intermittent periods.

**Operating Temperature:**  
 GNP: -100° F to +185° F (-74° C to +85° C)  
 GNT: -100° F to +225° F (-74° C to +107° C)  
 GNT (High Temp): -450° F to +800° F (-268° C to +427° C)  
 GSCP: -100° F to +185° F (-74° C to +85° C)  
 GSCPS: -100° F to +225° F (-70° C to +107° C)

\* Data based on water calibration @ 77° F (25° C).

## Standard Materials of Construction

### GNT, GBT, GFT and GIT

Housing and Supports: 316 Stainless Steel  
 Rotor: CD4MCu Stainless Steel  
 Shaft: Tungsten Carbide  
 Sleeve Bearings: Tungsten Carbide  
 Thrust Bearings: Tungsten Carbide  
 Retaining Rings: 300 Series Stainless Steel

### GNP, GBP, GFP, GIP and GSCP

Housing and Supports: 316 Stainless Steel  
 Rotor: CD4MCu Stainless Steel  
 Shaft: 316 Stainless Steel  
 Sleeve Bearings: PTFE Rulon®  
 Thrust Bearings: 440C Stainless Steel  
 Retaining Rings: 300 Series Stainless Steel

### GSCPS

Housing and Supports: 316 Stainless Steel  
 Rotor: Nickel Plated CD4MCu Stainless Steel  
 Shaft: 316 Stainless Steel  
 Sleeve/Thrust Bearing: PEEK  
 Retaining Rings: 300 Series Stainless Steel

Figure 7

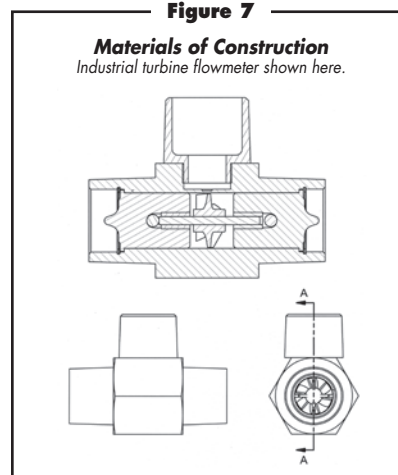

## Flow Related Formulas

<b>GPM</b> = $\frac{\text{Hz} \times 60}{\text{K-factor}}$	Pulses Per Litre = $\frac{\text{K-factor}}{3.785}$	Pounds Per Hour = $500 \times \text{S.G.} \times \text{GPM}$
<b>Hz</b> = $\frac{\text{GPM} \times \text{K-factor}}{60}$	Pulses Per Barrel = $\text{K-factor} \times 42$	Pounds Per Gallon = $\text{S.G.} \times 8.33 \text{ (Water)}$
<b>K-factor</b> = $\frac{\text{Hz} \times 60}{\text{GPM}}$	Pulses Per Cubic Meter = $\frac{\text{K-factor}}{.003785}$	<b>BPH</b> = $\text{GPM} \times 1.42857$
	Pulses Per Pound = $\frac{\text{K-factor}}{\text{Pounds Per Gallon}}$	<b>BPD</b> = $\text{GPM} \times 34.286$
	<b>GPM</b> = $\frac{\text{Pounds Per Hour}}{500 \times \text{S.G.}}$	<b>BPM</b> = $\text{GPM} \times 0.238$
		<b>GPS</b> = $\text{GPM} \times .01666$
		<b>GPD</b> = $\text{GPM} \times 1440.0$
		<b>GPM</b> = $\text{BPD} \times .029167$
		<b>GPM</b> = $\text{BPH} \times 0.7$
		<b>CFM</b> = $\text{GPM} \times .13368$

BPH = Barrels Per Hour	Minute
BPD = Barrels Per Day	GPS = Gallons Per Second
BPM = Barrels Per Minute	GPD = Gallons Per Day
CFM = Cubic Feet Per	GPM = Gallons Per Minute

### Pressure Drop vs. Flowrate

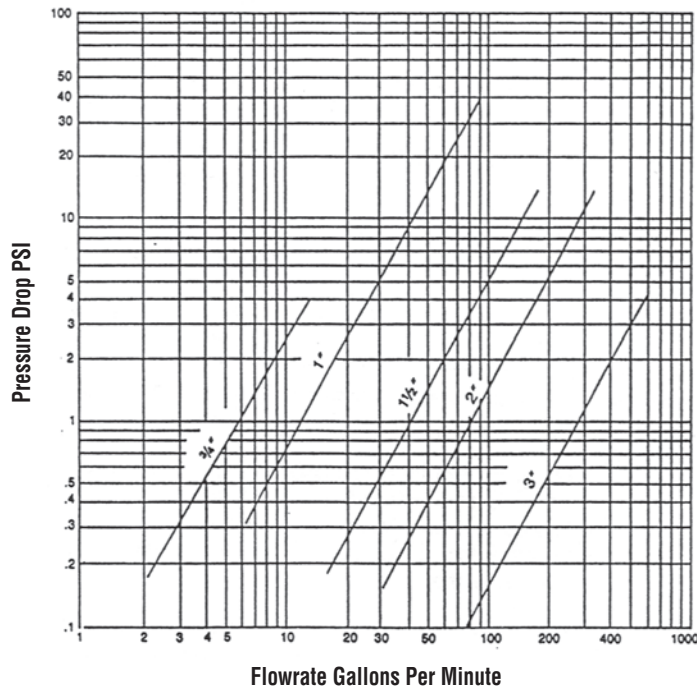

For estimating pressure drops on liquids other than water, use the following formulas:

$$P = [\text{VISC (CPS)}]^{1/4} \times [\text{S.G.}]^{3/4} [\text{PHO}]$$

Where: CPS = Absolute Viscosity in Centipoise  
 SG = Specific Gravity  
 PHO = Pressure Drop at the Operating Flowrate from the Chart

## SERVICE

For warranty consideration, parts, or other service information, please contact your local distributor. If you need further assistance, call the GPI Customer Service Department in Wichita, KS, during normal business hours.

**1-888-996-3837**

To obtain prompt, efficient service, always be prepared with the following information:

1. The model number of your turbine.
2. The serial number of your turbine.
3. Specific information about part numbers and descriptions.

For warranty work always be prepared with your original sales slip or other evidence of purchase date.

## Returning Parts

Please contact the factory before returning any parts. It may be possible to diagnose the trouble and identify needed parts in a telephone call. GPI can also inform you of any special handling requirements you will need to follow covering the transportation and handling of equipment which has been used to transfer hazardous or flammable liquids.

### CAUTION

**Do not return turbines without specific authority from the GPI Customer Service Department. Due to strict regulations governing transportation, handling, and disposal of hazardous or flammable liquids, GPI will not accept turbines for rework unless they are completely free of liquid residue.**

### CAUTION

**Turbines not flushed before shipment can be refused and returned to the sender.**