



# FB-BOOST

## BLDC IGNITION-PROOF REFRIGERANT RECOVERY UNIT

**20%<sup>OVER</sup>**  
**FASTER**  
THAN COMPETITION\*



Evaluated for performance in accordance with Sec. 608 of the Clean Air Act (Feb 29, 1996) using AHRI-740-2016 test methods.

ISA 12.12.01:2016 Ed.7  
Nonincendive Electrical Equipment  
For Use In Class I and II, Division 2 and  
Class III, Divisions 1 And 2 Hazardous  
(Classified) Locations

THIS EQUIPMENT HAS BEEN VERIFIED BY UNDERWRITERS LABORATORIES INC. TO MEET U.S. EPA'S MINIMUM REQUIREMENTS FOR RECOVERY EQUIPMENT INTENDED FOR USE WITH ALL SYSTEMS CONTAINING REFRIGERANTS FROM AHRI-740-2016 CATEGORIES III, IV, AND V. UL CONTROL NUMBER SA45599.



### OPERATING MANUAL

\*Speed based on vapor recovery for certain refrigerants.

1.800.561.8187

www.itm.com

information@itm.com

Thank you for selecting the **F6-BOOST Refrigerant Recovery Unit**. The F6-BOOST Refrigerant Recovery Unit provides users over 20% faster recovery rates than competitor models. The unique 2-cylinder, oilless compressor and long-lasting pistons are contained in a light-weight, ergonomically designed, easy-to-use unit. The F6-BOOST gives the user fast and reliable refrigerant recovery of ARHI groups III, IV, and V refrigerants.

Only qualified personnel trained in the handling of refrigerants should operate this piece of equipment. Working with refrigerants under pressures presents numerous safety risks and hazardous.

**Read and understand this operator’s manual and all safety materials before using. Failure to properly use this unit can result in personal injury and/or equipment damage.**

## TABLE OF CONTENTS

Box Contents . . . . .	2
F6-BOOST Features . . . . .	2
F6-BOOST General Safety Instructions . . . . .	3
F6-BOOST Flammable Refrigerant Safety Instructions . . . . .	4
F6-BOOST Refrigerant Storage Cylinder Safety. . . . .	5
F6-BOOST Specifications. . . . .	6
F6-BOOST Unit Layout . . . . .	7
F6-BOOST Unit Operation . . . . .	8
Direct Recovery . . . . .	8
Purge Procedure. . . . .	9
Liquid Push-Pull Recovery . . . . .	9
F6-BOOST Troubleshooting. . . . .	10
F6-BOOST Electrical and Plumbing Diagrams . . . . .	11
F6-BOOST Part Numbers. . . . .	11

## BOX CONTENTS

- F6-BOOST Refrigerant Recovery Unit
- 10' Locking power cord 115v
- Padded shoulder strap
- Operation Manual

## F6-BOOST FEATURES

- Dual voltage (100-240VAC 50/60Hz)
- Powerful 1.25 HP BLDC (Brushless DC) motor driven oil-less compressor
- Ignition-proof design tested and approved to ISA 12.12.01:2016 Ed.7
- High air flow fan with a micro-channel condenser to keep the unit running cool
- Variable speed motor (based on load)
- 2-piece, oilless piston seal design with long-lasting, durable elastomer, easy-to-replace piston seals
- Non-pressurized vented crank case (prevents refrigerant from damaging bearings or seals)
- Built in purge functionality (self clearing or pump down) to prevent cross contamination
- High pressure 550 PSIG cutout switch
- Easy-to-use interface with 2" high/low gauges
- Auto shut-off when recovery is complete
- Status Indicator light
- Optional stainless steel interior model for medical related industries
- Compact light-weight 24lb unit with robust, high-impact, injection-molded case
- Recessed folding handle with rubber grip and padded shoulder strap
- 10' locking power cable and velcro cord wrap
- 1 year OTC; 2-year repair and return warranty

# F6-BOOST GENERAL SAFETY INSTRUCTIONS

Please read, follow and understand the contents of this entire manual, with special attention given to Danger, Warning and Caution statements.

**FOR USE BY PROFESSIONALLY TRAINED AND CERTIFIED OPERATORS ONLY. MOST STATES, COUNTRIES, ETC., MAY REQUIRE USER TO BE LICENSED. PLEASE CHECK WITH YOUR LOCAL GOVERNMENT AGENCY.**

**DANGER:** The recovery tank used with this contains liquid refrigerant. Overfilling recovery tank may cause a violent rupture resulting in severe injury or even death. **As a minimum, please use a scale to continuously monitor recovery tank weight.**

**DANGER: EXPLOSION RISK!** This equipment can be used in Class I and II, Division 2 and Class III, Divisions 1 And 2 Hazardous (Classified) Locations. Technicians should be fully trained on services in this hazardous location.

**DANGER: ELECTRICAL SHOCK HAZARD:** Always disconnect power source when servicing this equipment.

**WARNING:** Do not use equipment in the vicinity of spilled or open containers of gasoline or other flammable substances.

**WARNING:** All hoses may contain liquid refrigerant under pressure. Contact with refrigerant may cause frostbite or other related injuries. Wear proper personal protective equipment such as safety goggles and gloves. When disconnecting any hose, please use extreme caution.

**WARNING: TO REDUCE RISK OF FIRE:** Avoid use of an extension cord because extension cord may overheat. If you must use an extension cord, use 10 awg minimum.

**WARNING:** Avoid breathing refrigerant vapors and lubricant vapor or mist. Breathing high concentration levels may cause heart arrhythmia, loss of consciousness, or even cause suffocation. Exposure may irritate eyes, nose, throat and skin. Please read manufacturer's Material Safety Data Sheet for further safety information on refrigerants and lubricants.

**WARNING:** Make certain all safety devices are functioning properly before operating equipment.

**CAUTION:** To avoid cross contamination of refrigerant and potential leakage to the atmosphere, proper hoses and fittings should be used and checked for damage.

**CAUTION:** To avoid overfilling refrigerant tank, read and follow manufacturer's recommended filling instructions for refrigerant being recovered.

**CAUTION:** This equipment is intended for use of one refrigerant at a time. Mixing of different refrigerants will cause your recovered supply of refrigerant to become contaminated.

Note: It is very expensive to destroy mixed or damaged refrigerants.



# F6-BOOST FLAMMABLE REFRIGERANT SAFETY INSTRUCTIONS

The following are additional safety recommendations when servicing HVAC&R equipment containing flammable refrigerants. These instructions do not replace existing occupational hazardous procedures or other local, state and/or federal agency regulations.

Technicians working on HVAC&R systems with flammable refrigerants should have detailed knowledge and skills in handling flammable refrigerants, personal protective equipment, refrigerant leak prevention, handling of cylinders, leak detection and monitoring, and proper disposal of contaminated refrigerants. Additional knowledge of legislation, regulations, and standards relating to flammable refrigerants may also be required. Check your local occupational safety codes.

The area of service should be marked as Temporary Hazardous or Flammable Zone. This will be a 3 meter (10 feet) perimeter around the HVAC&R equipment being serviced. No smoking signs or other hazardous zone signs should be posted. Local supervisor should be notified of the hazardous zone's existence.

The following are recommended practices when servicing flammable HVAC&R equipment:

- A flammable gas detector should be used to monitor the air in the Temporary Flammable Zone.
- A dry powder or CO2 fire extinguisher must be available at the service location.
- An ignition proof ventilation fan should be used to provide a minimum of 5 air changeovers per hour.
- Ensure the HVAC&R equipment has been disconnected from electrical service.
- All potential ignition sources within the Temporary Flammable Zone must be disabled.
- When connecting service equipment such as vacuum pumps, scales, recovery units, etc. to a power source, the connection must be made outside the Temporary Hazardous Zone perimeter.
- A grounding strap must be used between the recovery unit's metal INLET or OUTLET port and recovery tank's unpainted metal fitting. The grounding strap is used to dissipate any static electricity build up that can occur, especially during liquid recovery.
- Once the recovery process of the flammable refrigerant is complete, the HVAC&R system should be purged with 100% Nitrogen. Do not use air.

**DANGER - EXPLOSION RISK: Do not mix flammable refrigerants with air. All precautions must be taken to eliminate the mixing of air with flammable refrigerants, including monitoring the recovery cylinder of air or oxygen content.**

# F6-BOOST REFRIGERANT STORAGE CYLINDER SAFETY

Check with your federal and/or state regulations on the proper vessel to store refrigerant. In the USA, DOT CFR 40 is required when filling and transporting refrigerant storage vessels.

This unit is designed to be used with 400 PSIG rated storage vessels. In the USA, this is denoted by a DOT rating of 4ABA400 or 4BW400.

When recovering or filling a refrigerant storage vessel, never fill beyond 80% of its water capacity (WC). Filling a tank at 70F to 90% and then putting it in a hot service van will cause the liquid to expand until it becomes 100% full. The hydrostatic force of the refrigerant could rupture the tank causing rapid venting or explosion. See illustration in Diagram 1 below.

To calculate the maximum weight of a storage tank you will need to get two ratings from the tank. One is WC (water capacity) and the other is TW (empty tank weight). The maximum tank weight (MTW) is calculated as follows:

$$MTW = .8 \times WC + TW$$

Turn on the scale and tare to Zero. Place storage tank on scale. Read the weight. Compare that to the MTW calculated above. If the scale weight is below MTW, the difference is the amount of storage capacity you have in the tank. If the scale weight is above MTW, you have a tank that is overfilled.

If an overfill condition does exist on a storage tank, place in a cool area and transfer some of the refrigerant into another storage tank until the weight is below MTW.

Always use a calibrated scale to monitor the total weight of the tank when recovering or filling refrigerant into a storage tank. Devices such as tank overfill floats should stop the recovery unit, but do not stop the flow of refrigerant to the storage tank.

If the scale or an overfill device does detect tank full condition, the recovery unit should be turned off and the storage tank valves closed.

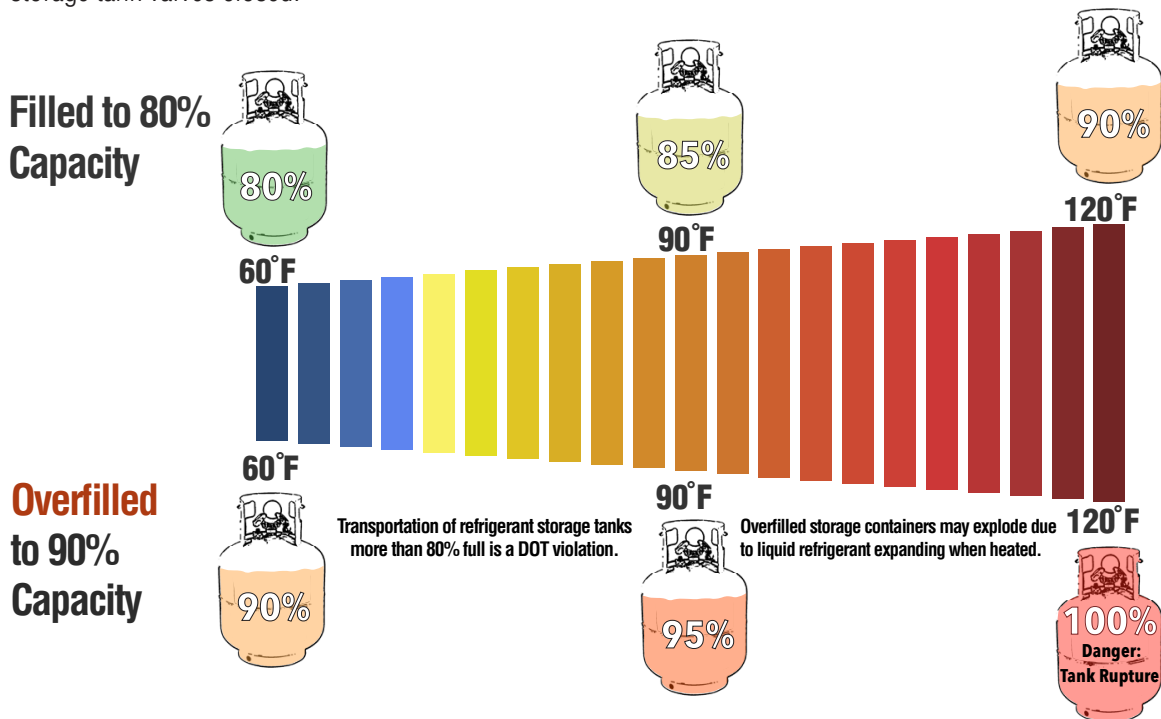

# F6-BOOST SPECIFICATIONS

<b>REFRIGERANTS</b>	<b>AHRI740 Class III</b> (120 - 169 PSIG @ 105°F Liquid Saturation)	R12, R134a, R401C, R406A, R500
	<b>AHRI740 Class VI</b> (170 - 269 PSIG @ 105°F Liquid Saturation)	R22, R401A/B, R402B, R407C/D/E/F, R408A, R409A, R411A/B, R412A, R502, R509A
	<b>AHRI740 Class V</b> (270 - 355 PSIG @ 105°F Liquid Saturation)	R402A, R404A, R407A/B, R410A/B, R507A
	<b>AHRI740 Class V, Type A2L pending</b> (270 - 355 PSIG @ 105°F Liquid Saturation)	R-32 pending
<b>POWER SUPPLY</b>		100-240VAC 1ph 50/60Hz
<b>MOTOR POWER</b>		1.25 HP
<b>MOTOR TYPE</b>		Variable Speed Brushless DC, 1200-3000 RPM
<b>MAXIMUM CURRENT</b>		13.0 amps
<b>COMPRESSOR TYPE</b>		2 Cylinder Oilless Reciprocating, Air Cooled
<b>HIGH PRESSURE CUTOUT (MANUAL RESET)</b>		550 PSIG
<b>OPERATING TEMPERATURE RANGE</b>		32°F to 120°F
<b>DIMENSIONS</b>		14.5" x 9.5" x 12.0"
<b>WEIGHT</b>		24lb
<b>CERTIFICATIONS</b>		Ignition-proof design tested and approved to ISA 12.12.01:2016 Ed.7

## ARHI740-2016 Performance Data certified by UL

Refrigerant	Direct Vapor	Direct Liquid	Push-Pull Liquid	High Temp. Vapor Rate
<b>R22</b>	0.77 lb/min	12.40 lb/min	13.43 lb/min	0.75 lb/min
	(0.35 kg/min)	(5.61 kg/min)	(6.08 kg/min)	(0.34 kg/min)
<b>R134a</b>	0.68 lb/min	9.97 lb/min	10.11 lb/min	
	(0.31 kg/min)	(4.53 kg/min)	(4.59 kg/min)	
<b>R410A</b>	0.76 lb/min	11.08 lb/min	15.34 lb/min	
	(0.34 kg/min)	(5.03 kg/min)	(6.96 kg/min)	
<b>R32 (estimate)</b>	0.76 lb/min	11.08 lb/min		
	(0.35 kg/min)	(5.03 kg/min)		

# F6-BOOST UNIT LAYOUT



## MANIFOLD VALVES and POSITIONS for operation

The unit is designed with a manifold containing 3 ball valves for Recovery, Liquid Push-Pull, and Purge (Self-Clearing or Pump Down) operations. The following table shows the proper position for each ball valve vs. the Operation.

Operation	INLET/PURGE Valve Position	OUTLET Valve Position	RECOVER/PURGE Valve Position
Recovery	OPEN	OPEN	RECOVER
Purge	PURGE	OPEN	PURGE
Liquid Push-Pull	OPEN	OPEN	PURGE
Off	CLOSE	CLOSE	RECOVER

# F6-BOOST OPERATION

## Direct Liquid or Vapor Recovery

The following are additional safety recommendations when servicing HVAC&R equipment containing refrigerant. This is the most common method of recovery operation for HVAC&R systems containing less than 20 kg of refrigerant. For larger systems PUSH-PULL LIQUID RECOVERY method can help speed up the process.

The following are step by step instructions on how to operate the recovery unit in Direct Liquid or Vapor Recovery.

The following is recommended to maximize recovery rates:

- A. Use the shortest length of 3/8" ID refrigeration hose on the suction side of the unit.
- B. If the refrigerant is clean, remove all suction side filters, screens, etc.
- C. Remove all Schrader type valve cores and any valve depressors from the hoses and service valves.
- D. Use an evacuated DOT tank.
- E. If the unit trips off on High Pressure, change the recovery cylinder.

1. Place a Refrigerant Storage Tank on a scale to determine the current weight of the tank.

**DANGER:** Make sure the storage tank has enough capacity for the recovery process. See Page 5 for refrigerant capacity and refrigerant storage tank safety guidelines.

2. Connect refrigerant hoses as shown in diagram below.
3. Turn the OUTLET valve to OPEN. Open Refrigerant Storage tank valve.
4. Turn the RECOVER/PURGE to RECOVER position
5. Plug in the unit into 115v or 230v power source. The Indicator LED will flash GREEN.
6. Push the START button. The Indicator LED will turn solid green. Once the unit's compressor starts turn the INLET valve to the OPEN position. If liquid refrigerant is being recovered and a slugging noise is heard, turn the INLET valve into the LIQUID region until the slugging noise subsides.

Monitor the electronic scale for weight gained during recovery and ensure the tank is not being overfilled. If approaching tank full conditions, push the Power Switch to OFF position and close tank valve. Replace tank with an empty one. Push the Power Switch to ON position to resume recovery operation.

7. The unit will automatically shut off after 2 minutes when the INLET pressure drops below 10" hg vac. The Indicator LED will turn solid YELLOW.
8. Monitor the Inlet gauge for a few minutes, if the pressure rises above 0 PSIG restart the unit by pushing the START button.

When Recovery is complete, proceed to Purge Procedure.

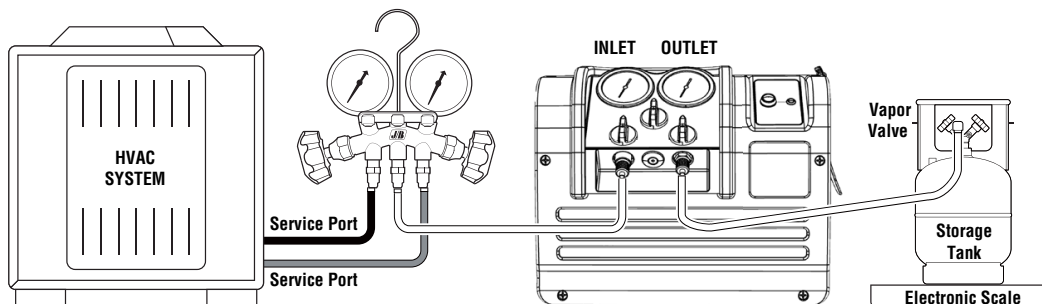

## Purge Procedure

It is necessary to clear out the unit's condenser of residual refrigerants. The unit utilizes a purge or self-clearing feature. Note: Failure to do this process will lead to cross-contaminated refrigerant.

1. Once recovery is done, turn the RECOVER/PURGE valve to the PURGE position
2. Push the START button. The Indicator LED will turn solid GREEN.
3. Turn the INLET valve to the PURGE position

4. Monitor the INLET gauge.
5. The unit will automatically shut off after 2 minutes\* when the internal condenser pressures drops below 10" hg vacuum. The Indicator LED will turn solid YELLOW.
6. Close all tank valves, hose valves and the unit's valves. Disconnect all hoses.

Purge is now complete. The unit is ready for the next refrigerant.

\*Note: Purge can be manually stopped before the 2 minute timer automatically turns off the unit.

## Liquid Push-Pull Recovery

The LIQUID PUSH-PULL RECOVERY operation is used on large HVAC&R Systems containing more than 20KG of liquid refrigerant. The unit must have an access valve that is located in the part of the system were liquid refrigerant is present.

The following are step by step instructions on how to operate the recovery unit in LIQUID PUSH-PULL RECOVERY.

1. Place a Refrigerant Storage Tank on a scale to determine the current weight of the tank.

**DANGER:** Make sure the storage tank has enough capacity to recover the refrigerants. See Page 5 for Tank Capacity and safety issues on refrigerant storage tanks.

**WARNING:** Liquid recovery rates can be very fast. Overfilling a tank can happen quite quickly if the unit is not monitored properly.

2. Connect refrigerant hoses as shown in diagram below.
3. Turn the OUTLET valve to OPEN. Open Refrigerant Storage tank valve.
4. Turn the RECOVER/PURGE to PURGE position
5. Plug in the unit into 115v or 230v power source. The Indicator LED will flash GREEN.
6. Push the START button. The Indicator LED will turn solid GREEN. Once the unit's compressor starts, turn the INLET valve to the OPEN position.

Monitor the electronic scale for weight gained during recovery and ensure the tank is not being overfilled. If approaching tank full conditions, push STOP button and close tank valve. Replace tank with empty one. Push START to resume recovery operation.

7. Monitor the scale to see if liquid refrigerant is no longer being pushed into the refrigerant storage tank. Close Tank Vapor Valve.
8. Once the INLET pressure drops below 10" hg vac, the unit will automatically shut off after 2 minutes and the Indicator LED will turn solid YELLOW.

LIQUID PUSH-PULL Recovery is now complete; proceed to Direct Vapor Recovery on page 8 to complete the recovery process.

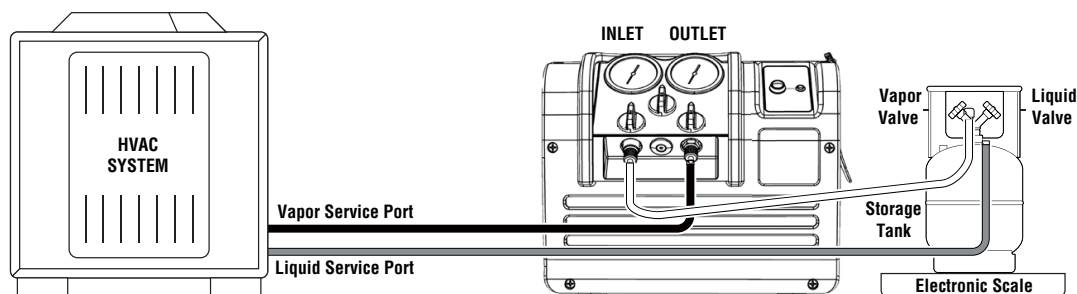

# F6-BOOST TROUBLESHOOTING

Problem	Possible Cause	Solution
Unit will not turn ON	Unit not properly plugged in or no power at power source	Check power cord to ensure properly plugged into power source and IEC inlet
	Defective Power Switch or PCB	Replace defective electrical component
Recovery process is slow	Plugged INLET Filter	Check INLET port filter, Clean or replace
	Valve core on system being recovered not fully depressed	Check core depressor on connecting hoses
	Compressor seals are worn	Rebuild compressor, replace piston seal
Unit does not pull a vacuum	Loose hose connections on IN Side	Tighten hose connections
	Compressor seals are worn	Replace piston seals

RED LED Code	Fault Indicated	Possible Solution
2 Flashes	Optional Tank Overfill Sensor has been activated	Tank overfill sensor has activated. Replace recovery tank.
		Tank overfill sensor cord not connected. Either connect to a recovery tank equipped with overfill sensor, or install a shorting plug on the end of the Tank Overfill Sensor cord.
3 Flashes	High Pressure Switch as been activated	Pressure on the discharge of the unit exceeded 550 PSIG. Check to make sure all valves in the discharge pathway are open. Once corrected, the pressure switch will reset. If equipped with manual high pressure switch, push reset button.
		Excessive pressure in recovery tank. Replace recovery tank.
4 Flashes	Motor Fault	Let cool down for 5-10 minutes and restart.
		Compressor Mechanism is jammed. Repair will be required to fix the compressor mechanism.

# F6-BOOST ELECTRICAL AND PLUMBING SCHEMATICS

## Electrical Schematic – Universal Voltage

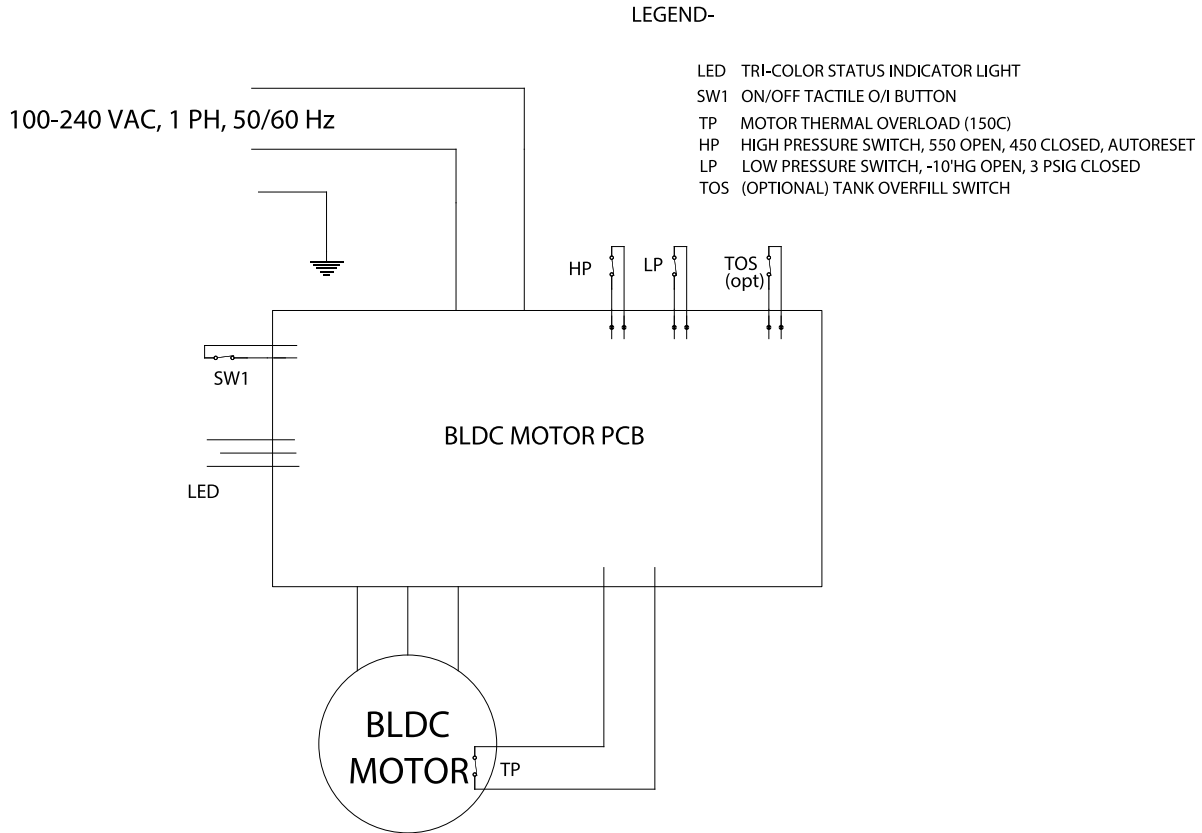

## Plumbing Schematic

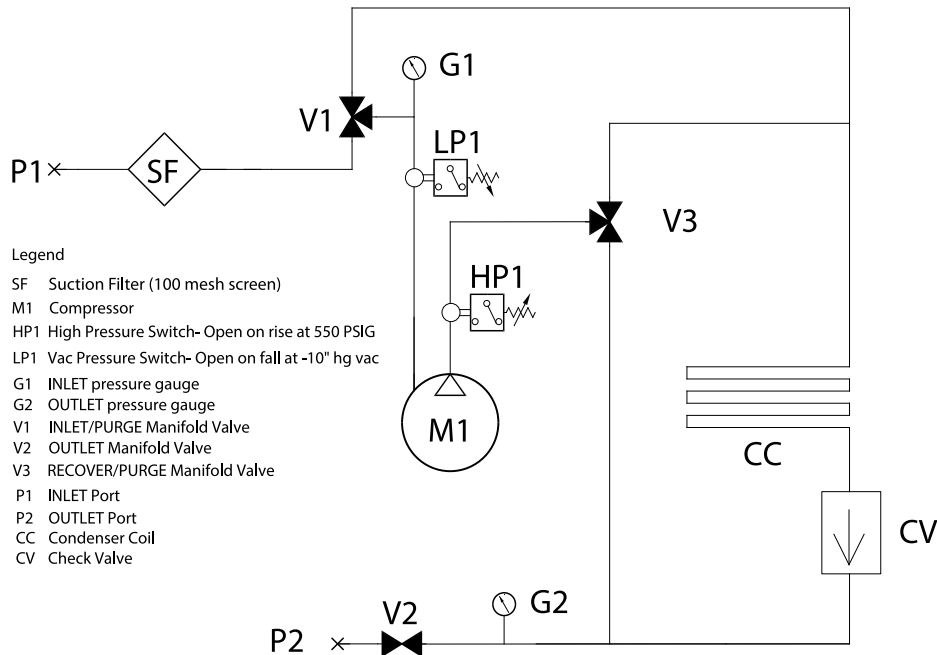

# F6-BOOST PART NUMBERS

PART NO.	DESCRIPTION
<b>F6-BOOST</b>	BLDC Ignition-Proof Refrigerant Recovery Unit
<b>F6-BOOST-SS</b>	BLDC Ignition-Proof Refrigerant Recovery Unit (Stainless Steel)
<b>F6-BOOST-TOC</b>	Optional tank overflow switch

## RETURN FOR REPAIR

Every effort has been made to provide reliable, superior quality products. However, in the event your instrument requires repair, please contact JB Customer Service Department to obtain a Return Goods Authorization (RGA) number. Ensure that all returned products are packed to avoid any damage in shipment. Paperwork should be placed in a separate plastic bag and should include JB's assigned RGA number, a description of the problem and any customer assigned repair or purchase order number, if applicable.

### Contact Customer Service for RGA number:

800.323.0811 Toll  
800.552.5593 Toll Fax

### Products should be shipped with freight prepaid to:

**JB Industries**  
RGA# \_\_\_\_\_  
601 N. Farnsworth Ave.  
Aurora, IL 60505

## WARRANTY

The F6-BOOST is warranted against defects in materials and workmanship for 2 years from date of purchase. 1 year OTC and 2- year repair and return warranty. JB products are guaranteed when used in accordance with our guidelines and recommendations. Warranty is limited to the repair, replacement, or credit at invoice price, (our option) of products which in our opinion are defective due to workmanship and/or materials. In no case will we allow charges for labor, expense or consequential damage. Repairs performed on items out of warranty will be invoiced on a nominal basis; contact wholesaler for details. Additional product information available online at [www.jbind.com](http://www.jbind.com).

**WARNING:** This product can expose you to chemicals including lead which are known to the State of California to cause cancer and birth defects or other reproductive harm. For more information go to [www.P65Warnings.ca.gov](http://www.P65Warnings.ca.gov).



# JB INDUSTRIES

0821