



## EV/DV300 Series Power Meter User's Manual

**ACCUENERGY**

1.800.561.8187

www.**itm**.com

information@itm.com

**Copyright© 2013 V3.1**

This manual may not be reproduced in whole or in part by mimeograph or any other means without the written permission of Accuenergy Tech.

The information contained in this document is believed be accurate at the time of publication, however, Accuenergy assumes no responsibility for any errors which may appear here and reserves the right to make changes without notice. Please ask the local representative for latest product specifications before ordering.

Please read this manual carefully before doing installation, operation and maintenance of the meter. Following symbols are used in this manual and on meter to alert the dangerous or prompt in the operating or setting process.



Danger symbol, failure to observe the information may result in injury or death.



Alert symbol, alert the potential danger.



Prompt symbol, this symbol is used where the meter may be damaged.

The meter must be well grounding before being operated or done maintenance. Installation and maintenance of the meter should only be performed by qualified personnel that have appropriate training and experience with high voltage and current device.

# CONTENTS

<b>Chapter 1: Introduction .....</b>	<b>6</b>
1.1 Description of EV/DV300 .....	6
1.2 Application Area.....	7
1.3 EV/DV 300 Series .....	7
<b>Chapter 2 Installation .....</b>	<b>10</b>
2.1 Appearance and Dimensions .....	10
2.1.1 Appearance .....	10
2.1.2 Dimension (mm) .....	11
2.2 Installation .....	11
Installation Steps.....	12
2.3 Wiring.....	13
Safety Earth Connection .....	14
Auxiliary power .....	14
Voltage Input.....	15
Current Input.....	16
2.4 I/O Wiring Method.....	18
<b>Chapter 3: Operation and Setting.....</b>	<b>24</b>
3.1 Display Panel and Keys.....	24
3.2 Metering Data Reading .....	25
3.3 Meter Parameter Setting .....	29
<b>Chapter 4: Communications.....</b>	<b>38</b>
4.1 Modbus Protocol Introduction .....	38
4.2 Format of Communication .....	40
4.3 Data Address Table .....	46
<b>Appendix.....</b>	<b>51</b>
Appendix A Technical Data and Specification.....	51
Appendix B Ordering Information .....	54

# *EV/DV300 Series Power Meter*

## **Chapter 1: Introduction**

---

### **1.1 Description of EV/DV300**

### **1.2 Application Area**

### **1.3 Meter Overview**

## Chapter 1: Introduction

### 1.1 Description of EV/DV300

#### Powerful and Economical

EV/DV300 series power meter is designed for three phase electrical parameter measurement by using of latest microprocessor and digital signal process technology. It can True-RMS measure Voltage, Current, Power, Reactive Power, Power Factor, Frequency and Energy. The meter can be well used in high harmonic environment especially in middle and low voltage power system, electric apparatus, power system automation and factory automation. All the measuring electrical data are available via digital RS485 communication port running Modbus™ Protocol. The meter also got some flexible I/O ports that made the metering, monitoring, remote controlling and Analog output in one unit possible. This can save large cost for user in setting up electric power automation system.

#### Small Size & Easy Install

EV/DV300 series was designed in compact size DIN96\*96 and reduced depth 60mm. It is suitable for small cabin installed in switch gear. Easy install and remove on panel by using clips.

#### Display Clear and Easy to Use

Large character LCD characters with blue back light made the display easy to read even under the dark light. All the Value reading and parameter setting can be access by using 4 panel keys or communication port. The meter parameters are protected in EEPROM, which will maintain its content after the meter is power off.

#### High Level Reliability and Safety

Multi-isolation and anti-interference methods were adopted in the EV/DV design according to the industry standards. The meter can be installed in hazard industry area. Also the meter was tested under IEC standards and EMC standards. The meter house was design by using glass polymer which is durable and inflaming retarding.

## 1.2 Application Area

EV/DV 300 series meter can be used to replace analog meter, panel meter, transducer and small RTU in power distribution or power automation system. As it adopted true-RMS measuring method, the EV/DV 300 series are competent for measuring voltage and current in high distortion nonlinear load system, such as VVVF, Electric Ballast, Computer etc. It's application area includes:

- Power Distribution Automation
- Intelligent Electric Switch Gear
- Industrial Automation
- Building Automation
- Energy Management Systems
- Industry Apparatus

## 1.3 EV/DV 300 Series

EV 300 series meter has functions of measuring, communication and I/O. EV36x is single measuring function meter with communication port, while EV38x and 390 is multi-function meter with communication port. For detail please refer to Table1.1.

DV300 series meter has functions of measuring and AO. DV30x is single measuring function meter while DV32X and DV330 are multi-function meters. For detail please refer to Table1.2.

Table 1.1 EV300 Series Power Meter

	Item	EV361	EV362	EV382	EV384	EV387	EV390
Metering	Voltage V	●		●		●	●
	Current I		●	●		●	●
	Power P				●		●
	Reactive Power Q				●		●
	Apparent Power S						●
	Power Factor PF				●		●
	Frequency Hz						●
Energy	Energy kWh					●	●
	Reactive Energy kVarh					●	●
I/O	Digital Input 2 DI	●	●	●	●	●	●
	DI Expanding 4 DI	⊙	⊙	⊙	⊙	⊙	⊙
	Relay Output/ Energy pulse Output 2 RO/DO	⊙	⊙	⊙	⊙	⊙	⊙
	Analog Output/ 24Vdc Power AO/PO	⊙	⊙	⊙	⊙	⊙	⊙
Comm	RS485 Modbus Protocol	●	●	●	●	●	●
Metering	Voltage V	●		●		●	●
	Current I		●	●		●	●
	Power P				●		●
	Reactive Power Q				●		●
	Apparent Power S						●
	Power Factor PF				●		●
	Frequency Hz						●
Energy	Energy kWh					●	●
	Reactive Energy kVarh					●	●
I/O	Analog Output AO	⊙	⊙	⊙	⊙	⊙	⊙
	Energy pulse Output DO	⊙	⊙	⊙	⊙	⊙	⊙

● Function ; ⊙ Option ; Blank NA

# *EV/DV300 Series Power Meter*

## Chapter 2: Installation

---

### 2.1 Appearance and Dimensions

### 2.2 Installation Steps

### 2.3 Wiring

### 2.4 I/O Wiring Method



## Chapter 2: Installation

### 2.1 Appearance and Dimensions

#### 2.1.1 Appearance

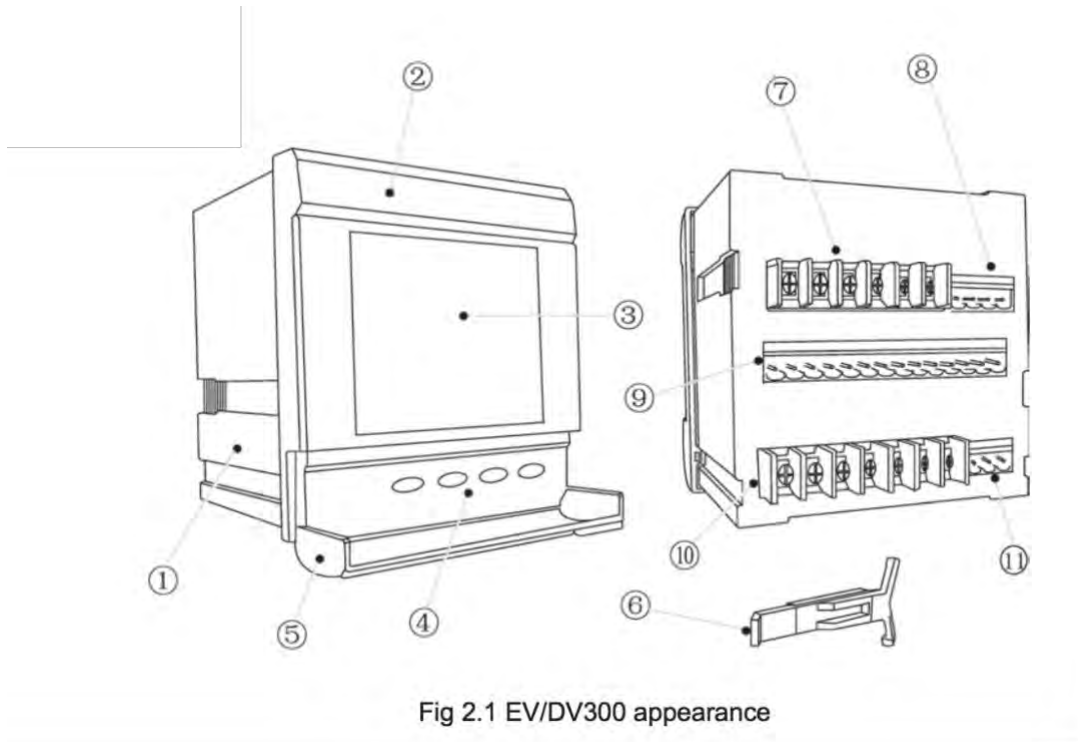

Fig 2.1 EV/DV300 appearance

Table 2.1 Part Name of Meter

Part Name	Description
1. House	Meter house is made of high Strength inflaming retarding glass-Polymer
2. Front Panel	Front Part of the meter
3. Display panel	LCD display panel
4. Key	Used to change display and setting the parameters
5. Key door	Used to protect pressing keys by mistake
6. Clip	Used to fasten the meter on the Electric panel
7. Current input terminal	Terminals for Current signal input
8. Terminal for DI	Terminals for 2 DI (DI1, DI2)
9. Terminal for I/O option	Terminals for 4DI(DI3, DI4, DI5, DI6), 2RO/DO and 2AO/1PO
10. Voltage Input Terminal	Terminals for Voltage input and power supply
11. Terminal for Comm	Terminals for RS485 port

### 2.1.2 Dimension (mm)

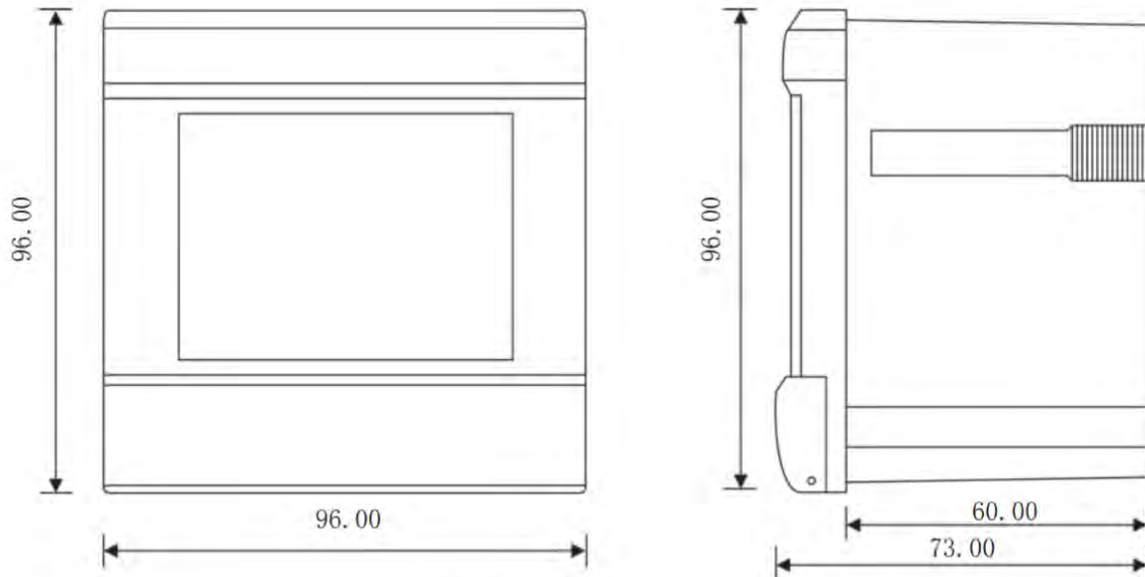
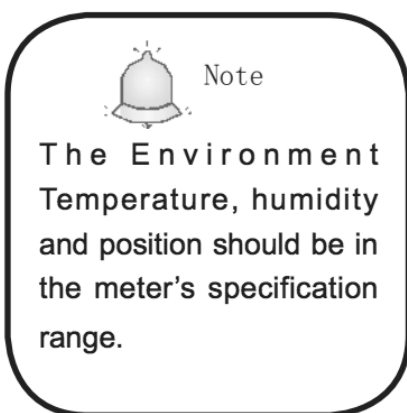

Fig 2.2 Dimension

## 2.2 Installation



Before installation, please make sure that the environment should satisfy the following conditions.

### 1. Temperature

EV/DV300 meter's working temperature range are from  $-20^{\circ}\text{C}$  to  $70^{\circ}\text{C}$ . If the meter is used beyond this range, it will result in unnormal performance or even permanent damage of the meter. EV/DV300 meter's storage temperature range is from  $-40^{\circ}\text{C}$  to  $85^{\circ}\text{C}$ .

### 2. Humidity

EV/DV300 meter's working humidity is from 0 to 95% non-condensing.

### 3. Position

EV/DV meter should be installed in dry and dust free environment and avoid heat, radiation and high electrical noise source.

## Installation Steps

### 1. Panel Cutting

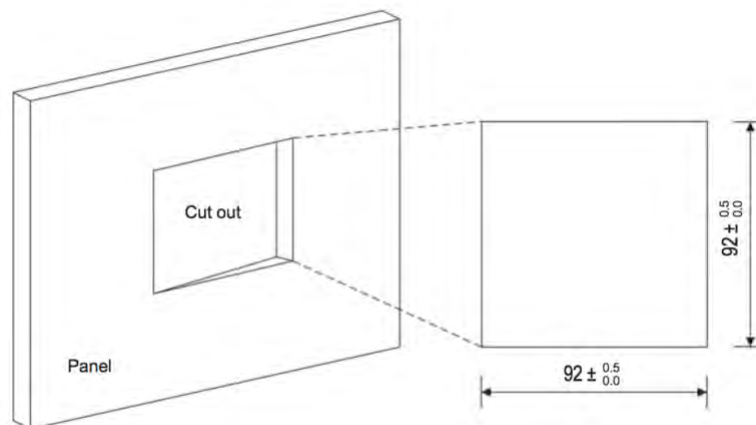

Fig 2.3 Panel Cutting

2. Secondly, remove the clips from the meter and insert the meter into the square hole from the front side.

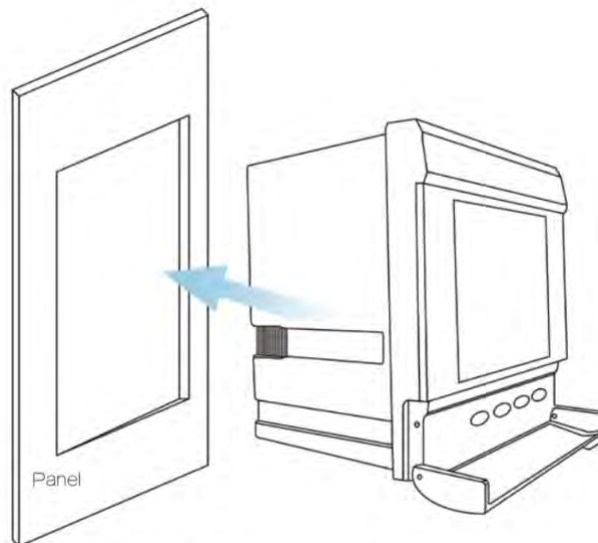

Fig 2.4 Put the meter into square hole

3. Finally, put clips back to the meter from the backside and push the clips tightly so that the meter is fixed on the panel.

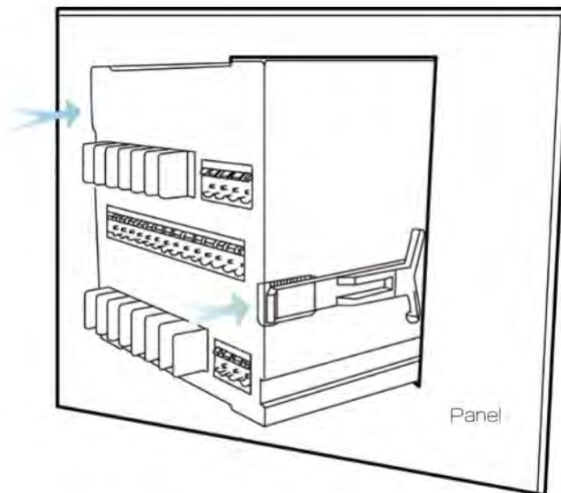
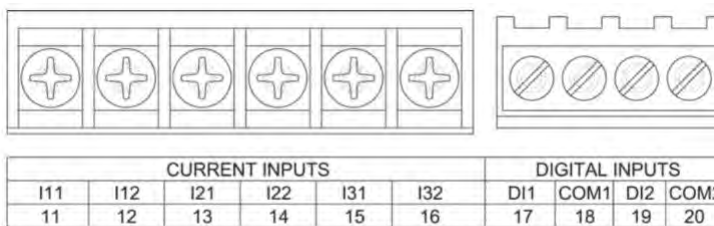

Fig 2.5 Use the clips to fasten the meter on the panel

## 2.3 Wiring

### Terminal Strips

There are 3 groups of terminals on the back of the meter, top, middle and lower one. The top group is for current input and 2 DIs. The middle group is for IO option and the lower group is for voltage input and communication.



a. Top group for current input, DI1 and DI2

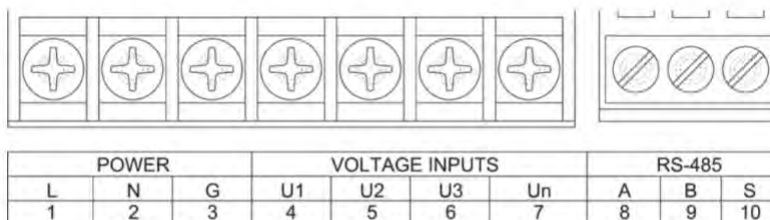

b. Lower group for Aux power, voltage input and Communication

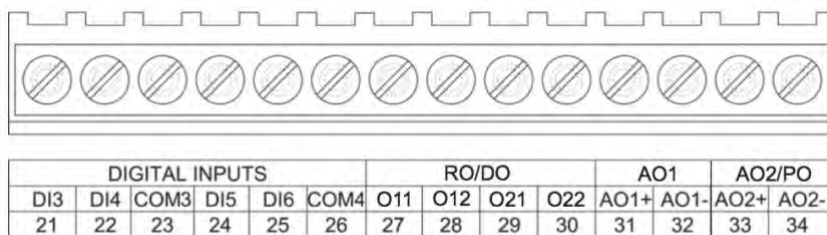

c. middle group for IO option

Fig 2.6 Terminal Groups

### Safety Earth Connection



**DANGER**

Only the qualified personnel could do the wire connection work. Make sure the power supply is cut off and all wires are not live. Failure to observe it may result in severe injury

Before doing the meter wiring connection, please make sure that the switch Panel has a safety Earth system. Connect the meter safety earth terminal to the switch gear safety earth system.

The following safety earth symbol is used in the user’s manual.



Fig 2.7 Safety earth symbol



**NOTE**

Make sure the voltage of power supply is the same as what the meter needed for its auxiliary power.

### Auxiliary power

The auxiliary power supply of the Acuvim meter is 85~264Vac (50/60Hz) or 100~280Vdc. Typical power consumption of the meter is less than 2.5W. Other type Aux. Power supply is available on order option.

Please contact our local sales representative.

Typical wiring of Aux. power supply is as following Fig 2.8.

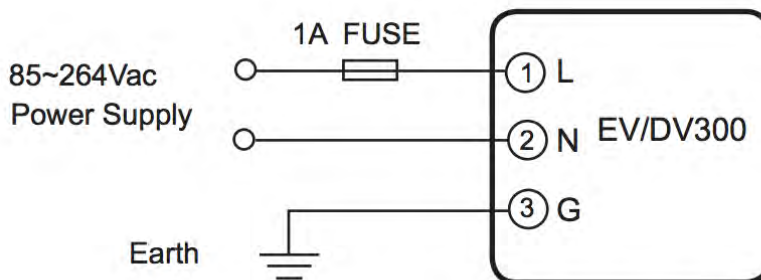

Fig 2.8 Wiring of Power Supply

The wire number of voltage input could be AWG16~22 or 0.6~1.5mm<sup>2</sup>. A fuse or circuit breaker should be used in Aux. power supply circuit. Fuse could be selected Long Time Delay 1A/250Vac one. No. 3 terminal must be connected to the safety earth system of switch gear. An isolated transformer or EMI filter should be used in the auxiliary power supply loop if there is power quality problem in the power supply. As in Fig 2.9.

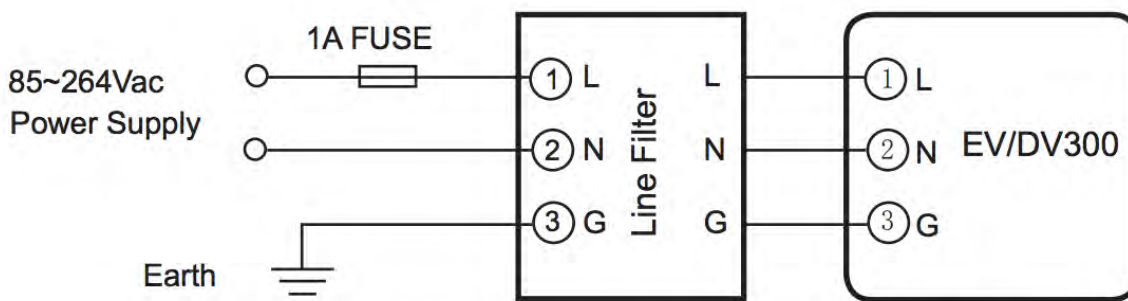

Fig 2.9 Wiring of Aux. Power Supply with power line filter



**NOTE**

The secondary of PT cannot be shorted, otherwise it may cause the severe damage of the instrument.

**Voltage Input**

Two Voltage Input options of EV/DV300 meter are 100Vac and 400Vac.

100Vac option is suitable for low voltage system that less than 120Vac in high or medium voltage system that the secondary of PT is 100Vac.

400Vac option is suitable for low voltage system that is less than 480Vac. The voltage input could be directly connected to the terminal of EV/DV300 without the use of PT.

A fuse (1A) or circuit breaker should be used in voltage input circuit. The wire number of voltage input could be AWG16~22 or 0.6~1.5mm<sup>2</sup>

**Note:** The secondary of PT cannot be shorted, otherwise it may cause the severe damage of the instrument. One end of the PT secondary should be connected to the earth. Please refer to the wiring diagram.

## Current Input

In a practical engineering application, CTs should be installed in the loop of measuring. Normally the secondary of CT is 5A. 1A is possible in the ordering option. A CT of accuracy over 0.5% (rating over 3VA) is recommended and it will influence the measuring accuracy. The wire between CT and meter should be as shorter as possible. The length of the wire may increase the error of the measurement.



### NOTE

The CT loop should not be open circuit in any circumstance when the power is on. There should not be any fuse or switch in the CT loop and one end of the CT loop should be connected to the ground.

The wire number of current input could be AWG15~16 or 1.5~2.5 mm<sup>2</sup>.

### Wiring of Un

Un is the reference point of electric potential for measuring. Low resistance may increase the measuring accuracy. Connecting point of Un has relation with system wiring method. Please referring to the wiring diagram.

### Wiring of the meter

Wiring method of EV/DV300 series meter will be introduced in the following paragraph. Please make sure that the primary and secondary voltage and current levels of PT and CT are suitable for the meter. The correctness of measuring result depends on the correct wiring and parameter setting of the meter.

- 1. Wye mode, 3CT  
(Wiring mode set 0)

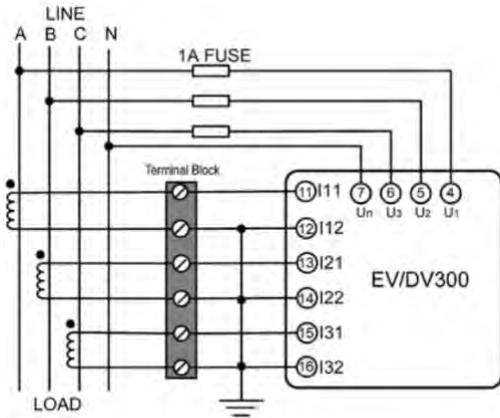

Fig 2.10 3LN, 3CT

- 2. Star mode, 2CT  
(Wiring mode set 0)

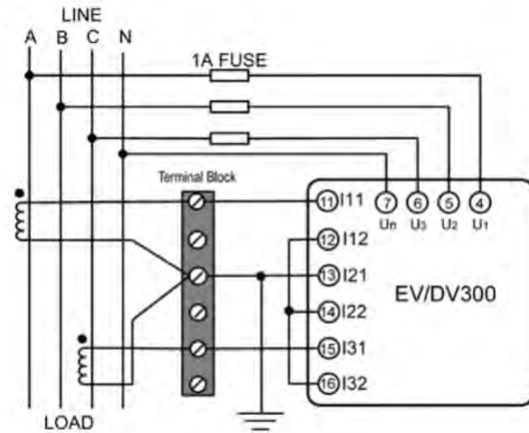

Fig 2.11 3LN, 2CT

- 3. Delta mode  
(Wiring mode set 2)

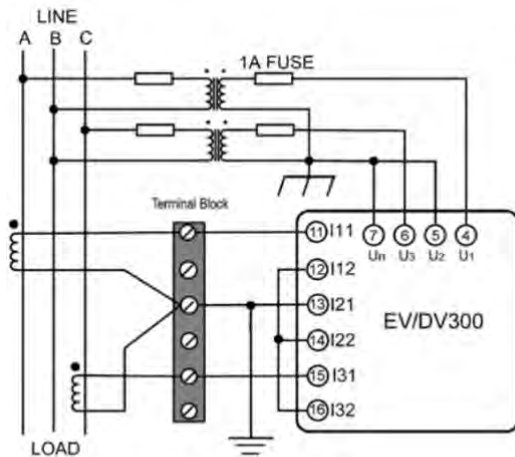

Fig 2.12 2LL, 2CT

- 4. Star mode  
(Wiring mode set 1)

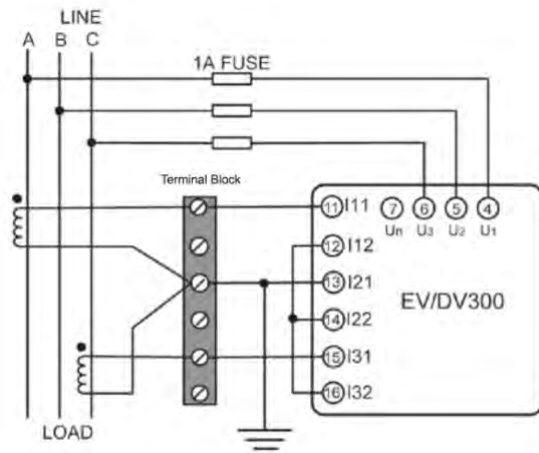

Fig 2.13 3LL, 2CT

5. Single Phase 2 wire  
(Wiring mode set 0)

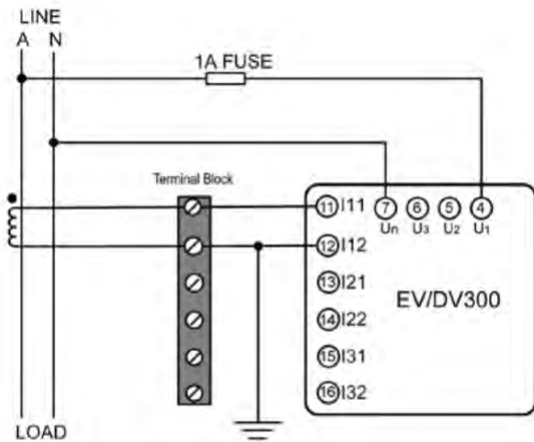

Fig 2.14 Single Phase 2 wire

6. Single Phase 3 wire  
(Wiring mode set 0)

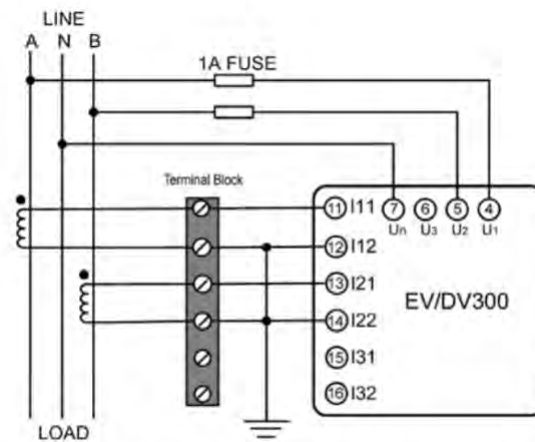

Fig 2.15 Single phase 3 wire

## 2.4 I/O Wiring Method

I/O option for EV/DV300 series meter can be 6 digital input, 2 relay output (or 2DO), 2 analog output (or 1PO) and a RS485 communication port.

### Digital Input

There are 2 digital inputs in the EV300 series meter (can be extended to 6 digital input) can be used as monitoring switch status and other digital input. DI1, COM1 (17, 18), DI2, COM2(19,20), DI3, COM3 (21, 23), DI4, COM3 (22, 23), DI5, COM4 (24, 26), DI6, COM4 (25, 26) are the terminal name and number. DI3 and DI4 use COM3 together while DI5 and DI6 use COM4. The simplified digital input diagram is as Fig 2.15:

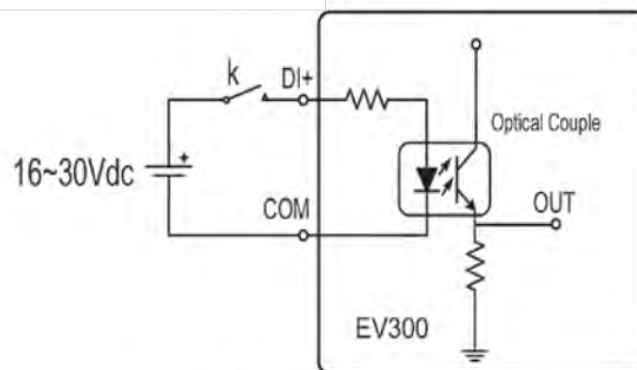

Fig 2.15 Digital Input Diagram

The voltage of the power supply connected with switch K is 16~30Vdc. The DI voltage can be higher for purpose of anti-noise if the loop is too long, but the Max current should be less than 10mA.

The wire number of DI could be AWG22~16 or 0.5~1.5mm<sup>2</sup>.

### Relay Output

There are 2 optional relay output used for electric switch control in EV300. Terminal name and number are R11, R12 (27,28) and R21, R22 (29,30).

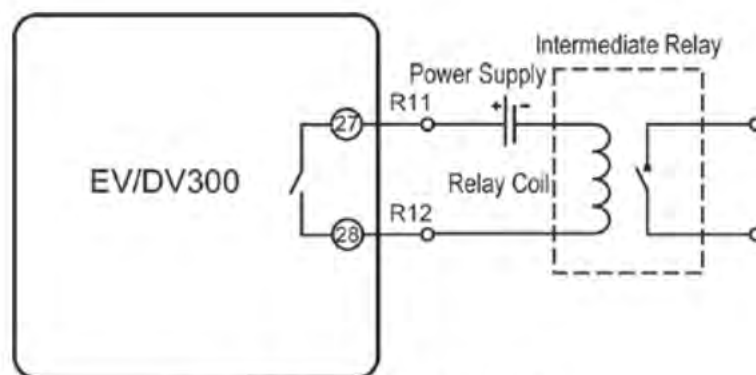

Fig 2.16 Relay Output

The 2 relays are form A or form B and 5A/250Vac or 5A/30Vdc. Please use intermediate relay when use them to control the electric switch.

There are two relay output modes for selection, one is latching, and the other is momentary. For the latching mode, the relay can be used to output two status on or off. For the momentary 23 EV/DV Series mode, the output of the relay changes from off to on for a period of time  $T_{on}$  and then goes off.  $T_{on}$  is fixed to 800ms.

The wire of relay output should be choosing between AWG22~16 or 0.5~1.5 mm<sup>2</sup>.

### Digital Output

There are two optional digital outputs used for energy pulse output in EV/DV300 series meter, DO1 is active energy output, and DO2 is reactive energy output. The terminal name and number are DO1+, DO1-(27,28) and DO2+,DO2-(29,30).

Pulse constant is related to ordering specification, the relationship is as follow: 100V/5A:20000; 400V/5A:3200; 400V/1A:20000;100V/1A:80000.

Digital outputs work in an open collector mode with electric coupling, The simplified circuit is shown as Fig 2.18.

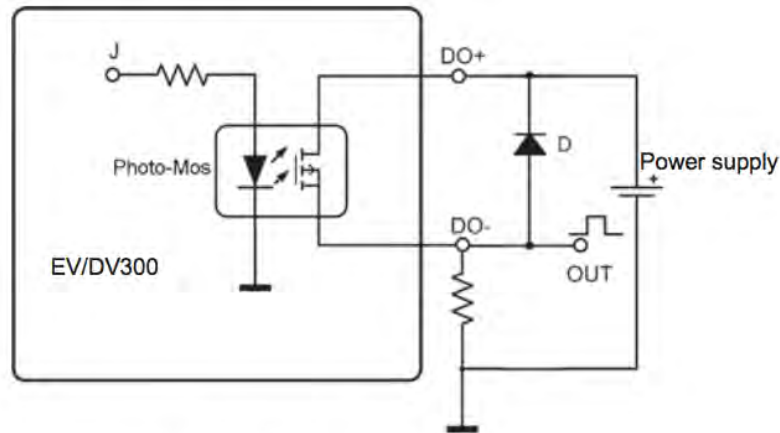

Fig 2.18 Digital Output

### Analog Output

There are two optional analog output in EV/DV300 series meter used in DCS or industry monitoring system. The analog output can be assigned to a metering parameter over front keys or communication. Please refer to Chapter 3.

The analog output mode can be anyone of 4~20mA, 0~1mA or 0~5V. The simplified circuit diagram is as in Fig 2.17. The default is 4~20mA. Other output mode can be selected at ordering.

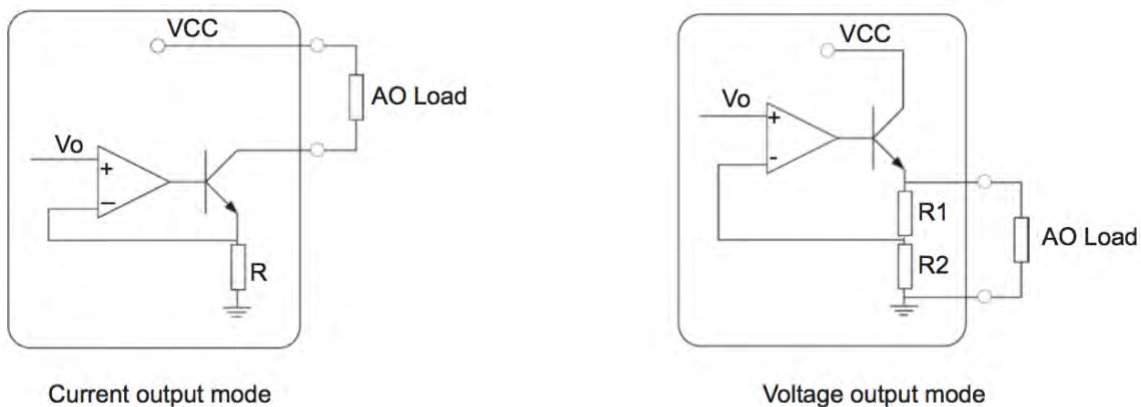

Fig 2.17 Analog Output

The max AO load for the 3 modes are,

4~20mA:

Max load resistor 500Ω

0~1mA:

Max load resistor 10kΩ

0~5V:

Max current 20mA

### 24Vdc Power Supply

There is an 24Vdc power supply in IO extend of EV300 series. The terminal name and number is AO2+, AO2- (33, 34), corresponding with (24V+, 24G). The voltage output range is 24V ( $\pm 10\%$ ), power rating is 2W and isolate voltage is 1000Vdc.

**Note:** Only one option can be chosen between 24Vdc power supply and Analog output.

### Alarm Output

There is an alarm function in EV300 series meter. The alarm will be triggered when a metering parameter is over the limit value and over the setting time limit. The alarm can be related to relay output or LCD back-light flashing. The setting of alarm is as following:

1. Set the relay output mode as alarm. (RO=2).
2. Assign metering parameter to alarm. (Refer Table 2-2)
3. Set alarm value limit.
4. Set alarm time limit. (Min time:1s, Range: 0~255s)
5. Sign of the inequation. (0: parameter value limit)
6. Relate to relays. (0:RO1, 1: RO2, 2: RO1 and RO2)

For register of setting parameters please refer to 4.3 of this manual. Serial number versus alarming parameter is listed in Table 2.2. Number 0 means no parameter is assigned to alarm.

Table 2.2 No. versus alarm parameter

No.	Parameter	No.	Parameter	No.	Parameter	No.	Parameter	No.	Parameter	No.	Parameter
1	U1	2	U2	3	U3	4	U12	5	U23	6	U31
7	I1	8	I2	9	I3	10	Uavg	11	ULavg	12	Lavg
13	P	14	Q	15	S	16	F	17	PF	18	In

#### Example:

Alarming parameter: I1,

Time limit: 15s,

Alarm output relay: RO1,

Rating of CT1 of I1: 200A,

Value limit: 180A.

The setting of alarm is as following:

1. Set the relay output mode as alarm. RO=2
2. The serial number of I1 is 7 from Table 2.2.
3. CT1=200, the equation converting between real value and register value is:

$$\text{Real value} = (\text{value in register} \times \text{CT1} \div 5) \div 1000$$

4. Time limit is 15s. The register value is 15.
5. The value is high limit, so the sign of in equation is 1 (great than). The alarm happens when register value > 4500.
6. The alarm relating relay is RO1, so the RO select 0. After finish above setting, the alarm will trigger RO1 and back-light flashing when value of I1 is over 180A and last over 15 seconds.

## Communication

The communication port and protocol of EV/DV300 are RS485 and Modbus-RTU. The terminals of communication are A, B, and S (11, 12, 13). A is differential signal +, B is differential signal -, and S is connected to shield of twisted pair cable. Up to 32 devices can be connected on a RS485 bus. Use good quality shielded twisted pair cable, AWG22 (0.5mm<sup>2</sup>) or larger. The overall length of the RS485 cable connecting all devices cannot exceed 1200m (4000ft). EV/ DV300 is used as a slave device of master like PC, PLC, data collector or RTU.

If the master does not have RS485 communication port, a converter has to be used. Normally a RS232/RS485 or USB/RS485 is adopted. The topology of RS485 net can be line, circle and star

The recommendations for the high-quality communication:

- Good quality shielded twisted pair of cable AWG22 (0.6mm<sup>2</sup>) or larger is very important.
- The shield of each segment of the RS485 cable must be connected to the ground at one end only.
- Keep cables away as much as possible from sources of electrical noise.
- Use RS232/RS485 or USB/RS485 converter with optical isolated output and surge protection.

# *EV/DV300 Series Power Meter*

## **Chapter 3: Operation and Setting**

---

**3.1 Display Panel and Keys**

**3.2 Metering Data Reading**

**3.3 Meter Parameter Setting**

## Chapter 3: Operation and Setting

### 3.1 Display Panel and Keys

There are one LCD display panel and four operation keys in the front of EV/DV300. All the segments in LCD display panel are display in Fig 3.1.

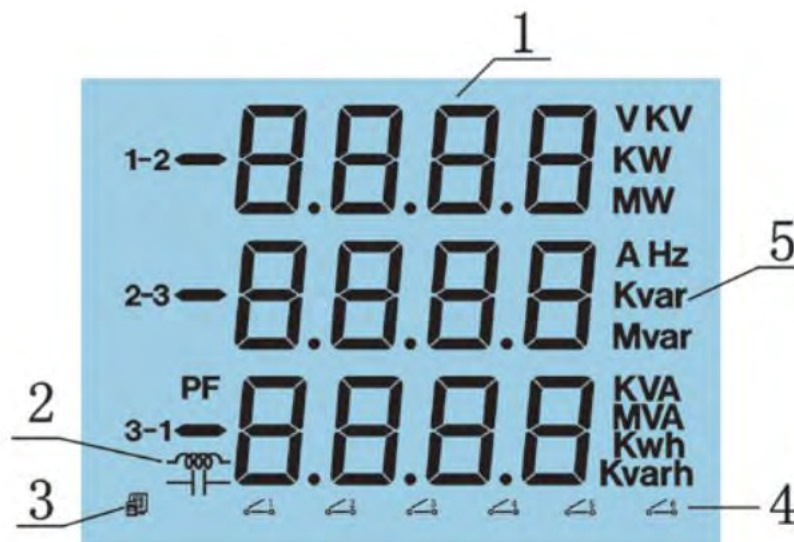









Fig 3.1 LCD display panel

Table 3.1 Some symbols on LCD panel

No.	Display	Meaning	Description
1		Data display	Display metering data V, I, P, PF, F, kWh etc.
2		Load Nature	Inductive or capacitive load
3		Icons of communication	No icon display: No communication data One display: Receiving data Two display: Receiving and transmitting data
4		DI Status	Switch 1-6: DI1-DI6
5		Unit	Indicate metering data unit

There are four fine keys labeled as , , E, P and V/A. Use these four keys to read metering data and do parameter setting.

The description in the following is based on EV390 meter. Other type of meter may lack some functions.

### 3.2 Metering Data Reading

In normal condition, the EV/DV300 meter is in the state of display the metering data, such as Voltage, current and power etc. To read the metering data simply press the keys E, P, and V/A.

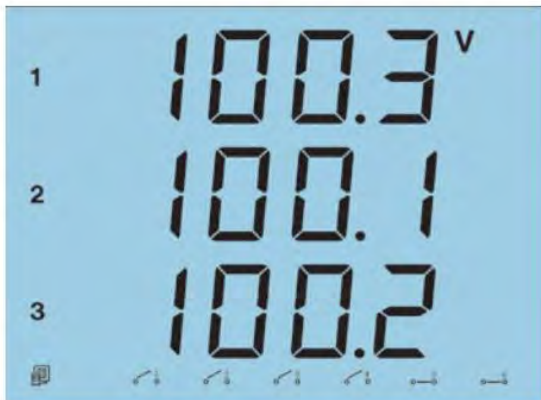

Fig 3.2 Voltage display

Press V/A to read voltage and current in the metering data area.

The first screen: display U1, U2, U3 and Uavg as in Fig 3.2. U1=100.3V; U2=100.1V; U3=100.2V; communication state normal; DI1, DI2, DI3 and DI4 open; DI5 and DI6 close.

Press V/A key go to the second screen.  
Note: Communication and DI states display in each screen.

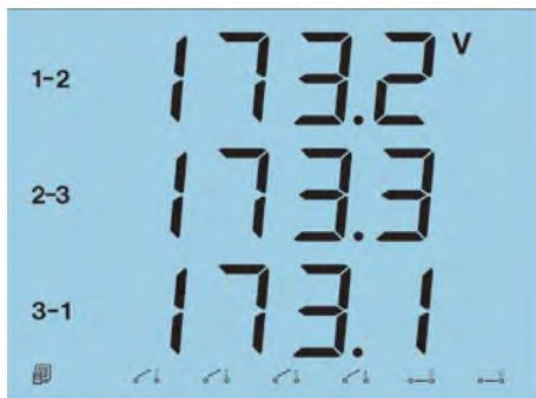

Fig 3.3 Line to line voltage

The Second screen: display line to line voltage U12, U23 and U31. As in Fig 3.3: U12=173.2V, U23=173.3V, U31=173.1V; communication state normal; DI1, DI2, DI3 and DI4 open; DI5 and DI6 close.

Press V/A key, go to the third screen.



Fig 3.4 Three phase current

The third screen: display current of each phase I1, I2, I3. As in Fig 3.4, I1=2.498A, I2=2.499A, I3=2.491A, communication status normal; DI1, DI2, DI3 and DI4 open; DI5 and DI6 close.

Press V/A, go to the fourth screen.



Fig 3.5 Uavg, ULavg and Iavg

The fourth screen: display average phase voltage, line voltage and current of 3 phase,  $U_{avg}$ ,  $U_{Lavg}$ , and  $I_{avg}$ . As in Fig 3.5:  $U_{avg}=100.2V$ ,  $I_{avg}=2.496A$ ,  $U_{Lavg}=173.2V$ ; communication status normal; DI1, DI2, DI3 and DI4 open; DI5 and DI6 close. Press V/A key, go to back to the first screen.

Press P key: display power, frequency, power factor in metering data area.



Fig 3.6 P, Q and S

The first screen: display real power P, reactive power Q and apparent power S. As in Fig 3.6:  $P=0.375kW$ ,  $Q=0.649kVar$ ,  $S=0.749kVA$ ; communication status normal; DI1, DI2, DI3 and DI4 open; DI5 and DI6 close.

Press P key, go to the second screen.



Fig 3.7 P, F and PF

The second screen: display real power P, frequency F and power factor PF. As in Fig 3.7:  $P=0.375kW$ ,  $F=50.00Hz$ ,  $PF=0.500$ ; inductive load; communication status normal; DI1, DI2, DI3 and DI4 open; DI5 and DI6 close.

Press P key, go back to the first screen.



Fig 3.8 Energy kWh

Press E key: display real energy and reactive energy in metering area.

The first screen: display real energy. As in Fig 3.8:  $E_p=38106.1\text{kWh}$ . Max energy counter is  $99999999.9\text{kWh}$ , it will go to 0 if the counter is over that value. The first line is the highest bits while the third line is the lowest bits of energy counter.

Press E key, go to the second screen.



Fig 3.9 Reactive Energy

The second screen: display reactive energy  $E_q$ . As in Fig 3.9:  $E_q=15521.7\text{kVarh}$ . Max reactive energy counter is  $99999999.9\text{kVarh}$ , it will go to 0 if the counter is over that value. The first line is the highest bits while the third line is the lowest bits of reactive energy counter.

Press E key, go back to the first screen.

### 3.3 Meter Parameter Setting



#### NOTE

The setting should be done by the professional after he has read this manual.

Under the data display mode, press and V/A keys simultaneously, get into the meter parameter setting mode.

In the meter parameter setting mode, press key to move cursor. Right move one digit each time.

Press E key for increasing and press P key for decreasing.

Press V/A key once for acknowledgment and press V/A key again going to the next setting page. Press and V/A keys simultaneously to exit in any setting mode page.

Press  $\triangleleft$  and V/A keys simultaneously, go into the parameter setting mode.

The first display page is communication address. As in Fig 3.10, the address is 17. Then after 3 Seconds, the display will automatically go to the access code page.



Fig 3.10 Comm address

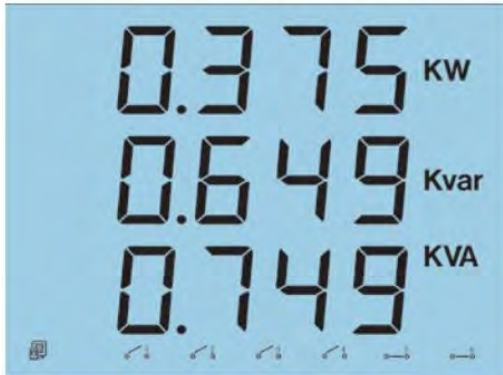

Fig 3.11 Access code

Access code is needed for going into the parameter setting mode. Only the person who knows the access code can do the parameter setting. The access code is 4 digits decimal number. It is from 0000 to 9999. The factory default is 0000. After key in the right access code, press V/A to go to the first parameter setting page, otherwise go back to the metering data display page.



Fig 3.12 Comm Address Setting

The first screen: Setting address for communication purpose in this page. It is any digit number from 1 to 255. As in Fig 3.12, the address is 17. Changing method is simple, press key to move cursor to the digit need to change and press E key for increasing or P key for decreasing. Then press V/A key for acknowledgment and go to the next setting page.

**Note:** Each meter on the same RS485 net should has different address according to the Modbus-RTU protocol.



Fig 3.13 Comm Baud rate Setting

The second screen: Baud rate setting page.

The communication protocol Modbus. RTU in meter is based on asynchronous mode: 8 data bit, no parity, 1 start bit and 1 stop bit. Baud rate could be one of the five, 1200, 2400, 4800, 9600, 19200 bps. As in Fig 3.13, the baud rate is 9600 bps. Press E key to select one baud rate. Press V/A key, go to the next setting page.

**Note:** Please use the same baud rate in meters on the same communication net.



Fig 3.14 PT1 Setting

The third screen: PT primary rating voltage PT1 setting page.

PT1 value is an integer from 100 to 500,000. The unit is volt. As in Fig 3.14, PT1=1000V. Use key for moving cursor, E key for increasing and P key for decreasing. Press V/A key, go to the next page.

**Note:** If there is no PT used in power system, PT1 and PT2 should be the same and equal to the rating voltage.

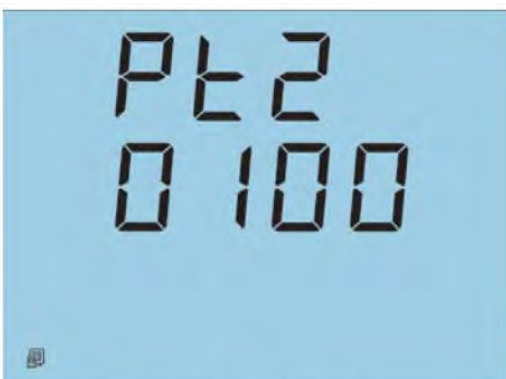

Fig 3.15 PT2 Setting

The fourth screen: PT secondary setting page. PT2 value is an integer from 100 to 400. The unit is volt. As in Fig 3.1, PT2=100V. Use key for moving cursor, E key for increasing and P for decreasing. Press V/A key, go to the next page.

**Note:** If there is no PT used in power system, PT1 and PT2 should be the same and equal to the rating voltage.

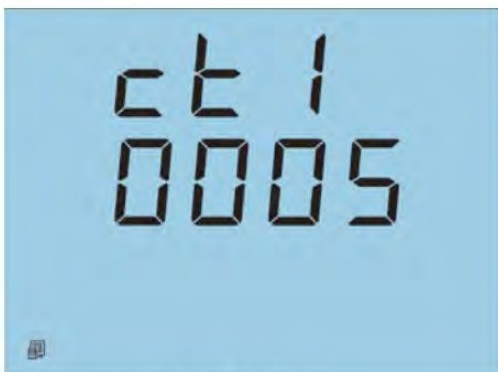

Fig 3.16 CT1

The fifth screen: CT primary setting page.

CT1 value is an integer from 5 to 10000. The unit is Amp. As in Fig 3.16, CT1=5A. Use key for moving cursor, E key for increasing and P key for decreasing.

Press V/A key, go to the next page.

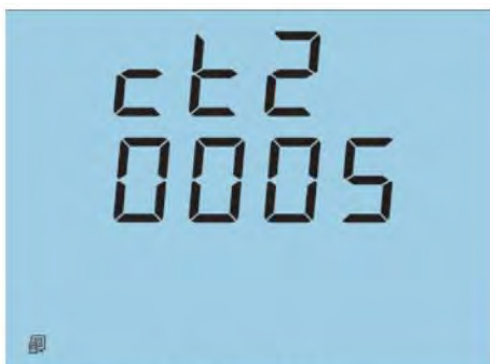

Fig 3.17 CT2

The sixth screen: CT secondary setting page. The default value of CT2 is 5A. 1A input is for option. As in Fig 3.17, CT2=5.

Press V/A key, go to the next setting page.

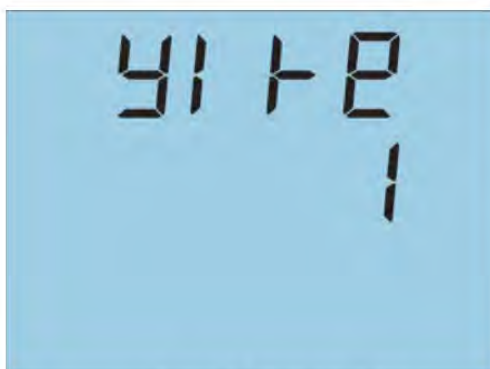

Fig3.18 Wiring type

The seventh screen: wiring setting page.

There are 3 kinds of wiring type in EV/DV300 meter, 3 phase 4 wire (0), 3 phase 3 wire direct connection (1), 3 phase 3 wire connection with 3CTs.

Press  $\triangleleft$  and E key to change wiring Type. Press V/A key for acknowledge and go to the next setting page.

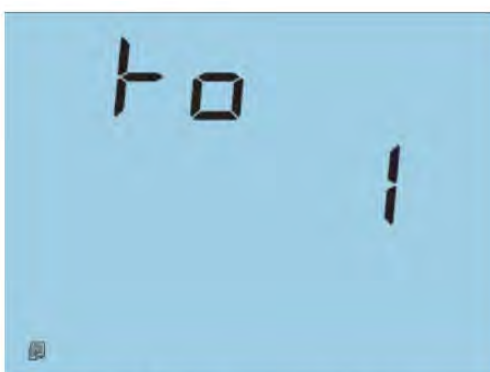

Fig 3.19 Relay output (RO)

The eighth screen: Relay output mode setting (this setting will be inoperative if Digital output is selected).

There are 2 working mode for the 2 relay outputs. One is Latching, the other is momentary. For the latching mode, the relay can be used as to output 2 status on or off. For the momentary mode, the output of the relay changes from off to on for a period of time  $T_{on}$  and then goes off.  $T_{on}=800ms$ . 0: latching, 1: momentary, 2: alarm. Use  $\triangleleft$  and E key to change the relay output working mode.



Fig 3.20 Analog output 1 (AO1)

When setting the relay output working as alarm output, the value should be set as 2.

Press V/A key, go to the next page.

The ninth screen: Analog output 1 (AO1) setting (this setting will be inoperative if PO is selected).

Analog output can be assigned to any one of 17 metering parameter, U1, U2, U3, U12, U23, U31, I1, I2, I3, Uavg, Uavg, lavg, P, Q, S, F and PF. The number is from 0 to 16 respectively. As

in Fig 3.20, the AO1 is assigned to U12. The number is 3.

The parameter table is displayed in Table 3-2.

Parameter table

No.	0	1	2	3	4	5	6	7	8	9	10	11	12	13	14	15	16
Data	U1	U2	U3	U12	U23	U31	I1	I2	I3	Uavg	ULavg	lavg	P	Q	S	F	PF

Table 3-2 Parameter table



Fig 3.21 Analog output 2 (AO2)

The tenth screen: Analog output 2 (AO2) setting

Analog output can be assigned to any one of 17-metering parameter. The number is from 0 to 16 respectively. As in Fig 3.20, the AO2 is assigned to lavg. The number is 12. Parameter table 0 U1 No. Data 1 U2 2 U3 3 U12 4 U23 5 U31 6 I1 7 I2 8 I3 9 Uavg 10 ULavg 11 lavg 13 Q 14 S 12 P Table 3-2 Parameter table 15 F 16 PF

**Note:** The Analog output mode can be chosen when ordering from 1 of the 3, 4-20mA, 0-1mA, 0-5V

The relation between metering parameter and output is illustrated in Fig 3.22, 3.23, 3.24.

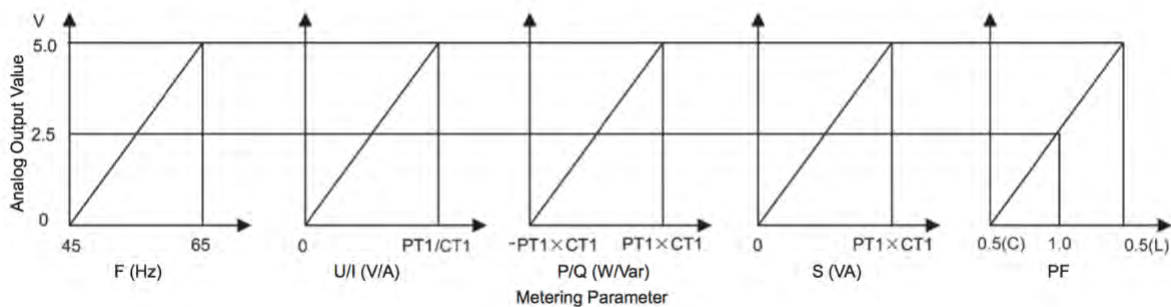
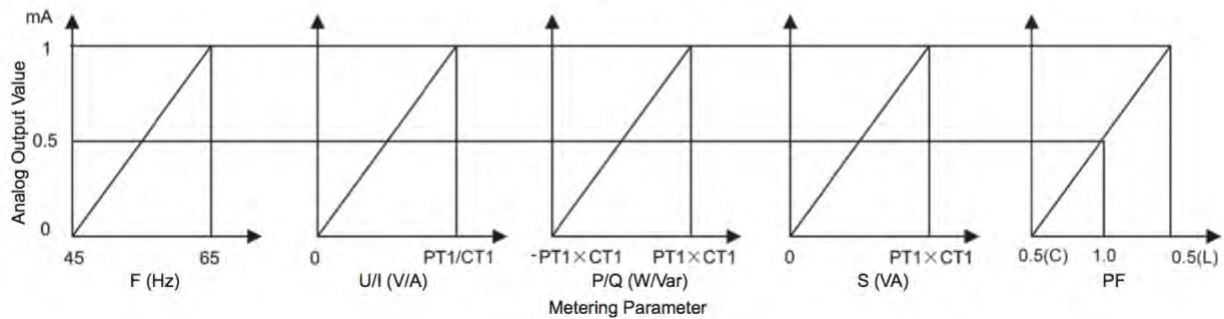
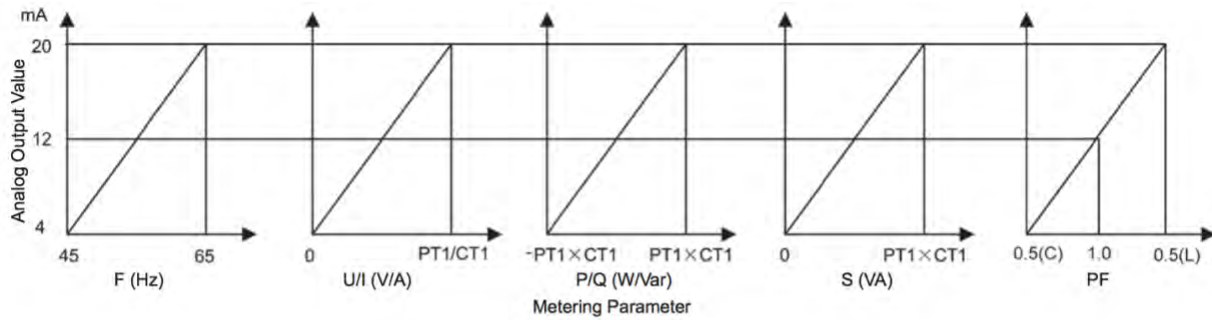



Fig 3.25 Real energy

The eleventh screen: real energy presetting page. Use  $\leftarrow$ ,  $\rightarrow$ , E and P key to preset the value of energy. As in Fig 3.25, the energy value is 8848.3kWh.

Press V/A to acknowledge and go to the next setting page.



Fig 3.26 Reactive Energy

The twelfth screen is reactive energy setting page. Use  $\leftarrow$ ,  $\rightarrow$ , E and P key to preset the energy value. As in Fig 3.26, the reactive energy is 0.0 Kvarh.

Press V/A key to acknowledge.



Fig 3.27 LCD back light time setting

The thirteenth screen is LCD back light time setting page. To reduce power consumption and increase the duration of the device, the backlight will turn off automatically if there is no key pressed down within a time interval, when any key is pressed down at any time, it will turn on immediately. The time interval can be set from 0 to 120 (minutes), when it is set to 0, the backlight will be always on. And the default is 2.



Fig 3.28 Access code setting

The fourteenth screen: access code setting page.

This is the last setting page. The access code is set in this page. As in Fig 3.28, the access code is 0001. Press V/A key, go back to the first page.

All the parameter is set till now. Press  $\leftarrow \triangleright$  and V/A key simultaneously, exit setting mode and back to the metering data display page.

The setting page may be different depending on the meter type. Please confirm the meter type before doing the parameter setting.

**Note:** Press key in the value inside the range of parameter define in Table 3.3. The parameter will return to default value if key in over range value.

Table 3.3 Range and default value of parameter

Parameter	Range	Default
Access code	0~9999	0
Address	1~255	1
Baud rate	1200, 2400, 4800, 9600, 19200	19200
PT1	100~500000	400
PT2	100~400	400
CT1	5~9999	5
CT2	5 (1 for option)	5
RO	0~1	0
AO1	0~16	0
AO2	0~16	0
Real energy	0~99999999.9	0
Reactive energy	0~99999999.9	0

# *EV/DV300 Series Power Meter*

## **Chapter 4: Communications**

---

### **4.1 Introducing Modbus Protocol**

### **4.2 Format of Communication**

### **4.5 Data Address Table**



## Chapter 4: Communications

### 4.1 Modbus Protocol Introduction

The Modbus RTU protocol is used for communication in EV300 series meter. The data format and error check field are defined in Modbus protocol. The half-duplex query and respond mode is adopted in Modbus protocol. There is only one master device in the communication net. The others are slave devices waiting for the query of the master.

#### 1. Transmission mode

The transmission mode defines the data structure within a frame and the rules used to transmit data. The mode is defined in the following table that is compatible with Modbus RTU mode.

- ▲ Coding System            8-bit binary
- ▲ Start bit                    1
- ▲ Data bits                    8
- ▲ Parity                        NO parity
- ▲ Stop bit                     1 bit
- ▲ Error checking            CRC (Cyclical Redundancy Check)

#### 2. Protocol

##### 2.1 Frame

The message frame should contain four parts, address of the slave device, function code define action of slave device, data of action and error check field.

Table 4.1 Data Frame

Address	Function	Data	Check
8-Bits	8-Bits	N x 8-Bits	16-Bits

##### 2.2 Address field

The address field of a message frame contains eight bits. Valid codes are in the range of 0-255 decimal. When a message is sent from a master to a slave device the function code field tells the slave what kind of action to perform.

**2.3 Function code**

The function code field of a message frame contains eight bits. Valid codes are in the range of 1-255 decimal. When a message is sent from a master to a slave device the function code tells the slave what kind of action to perform.

Table 4.2 Function code

Code	Meaning	Action
01	Read RO Status	us Obtain current status of Relay Output (ON/OFF)
02	Read DI Status	Obtain current status of Digital Input (ON/OFF)
03	Read data	Obtain current binary value in one or more registers
05	Control RO	Force Relay to a state of on or off (ON/OFF)
16	Preset Registers	Place bin value into consecutive Mutiple-Register

**2.4 Data Field**

The data field of message send from a master to slave device or from slave to master contain additional information which the slave must use to take the action defined by the function code or the result of action.

**2.5 Error Check field**

This field permits to check error during the data transmit process. A group of data transmit from one device to the other may get error as there exist noise in transmission line. The receiving device will not respond to the error message. The error check field is based on a Cyclical Redundancy Check (CRC16) method.

**3. Error Check**

Error checking field is based on a Cyclical Redundancy Check (CRC) method. The CRC field checks the contents of the entire message. It is applied regardless of any parity check method used for the individual characters of the message. The CRC field is two bytes, containing a 16-bit binary value. The CRC value is calculated by the transmitting device, which appends the CRC to the message.

The receiving device recalculates a CRC during receipt of the message, and compares the calculated value to the actual value it received in the CRC field. If the two values are not equal, an error results.

The CRC is started by first pre-loading a 16-bit register to all 1's. Then a process begins of applying successive 8-bit bytes of the message to the current contents of the register. Only the eight bits of data in each character are used for generating the CRC. Start and stop bits, and the 51 EV/DV Series parity bit, do not apply to the CRC. During generation of the CRC, each 8-bit character is exclusive ORed with the register contents. Then the result is shifted in the direction of the least significant bit (LSB), with a zero filled into the most significant bit (MSB) position. The LSB is extracted and examined. If the LSB was a 1, the register is then exclusive ORed with a preset, fixed value. If the LSB was a 0, no exclusive OR takes place. This process is repeated until eight shifts have been performed. After the last (eighth) shift, the next 8-bit byte is exclusive ORed with the register current value, and the process repeats for eight more shifts as described above. The final contents of the register, after all the bytes of the message have been applied, is the CRC value. When the CRC is appended to the message, the low-order byte is appended first, followed by the high-order byte.

## 4.2 Format of Communication

Explanation of frame (Hex)

Table 4.3 Frame example

Addr	Fun	Data start reg hi	Data start reg lo	Data #of regs hi	Data #of regs lo	CRC16 hi	CRC16 lo
06H	03H	00H	00H	00H	21H	84H	65H

In Table 4.3, the meaning of each abbreviated word is,

Addr:	address of slave device
Fun:	Function code
Data start reg hi	Start register address high (high byte)
Data start reg lo	Start register address high (low byte)
Data #of reg hi	Number of register (high byte)
Data #of reg lo	Number of register (low byte)
CRC16 Hi:	CRC (high byte)
CRC16 Lo:	CRC (low byte)

**1. Read Status of Relay (function code 01)**

**Query**

Query message is sent from master to slave device. This function code is used to read status of Relay Output in slave device. (1=ON,0=OFF), There are 2 relays in the meter. The address of each relay is Relay1=0000H and Relay2=0001H.

Table 4.4 Example of read RO status from slave No.17.

Addr	Fun	Data start reg hi	Data start reg lo	Data #of regs hi	Data #of regs lo	CRC16 hi	CRC16 lo
11H	01H	00H	00H	00H	02H	BFH	5BH

**Response**

Response frame message is from slave to master device. The frame includes address, function code, quantity of data byte, the data and CRC error checking. The data byte contains the information of status of 2 Relays. The last 2 bits tells the status of Relays. Relay 1 status relates to LSB and Relay 2 to next left bit of LSB. (status Off=0 and on=1)

Table 4.5 Example response of reading status of Relays.

Addr	Fun	Byte Count	Data	CRC16 hi	CRC16 lo
11H	01H	01H	02H	D4H	89H

The content of Data byte

Table 4.5 Read status of Relay1 and Relay2

0	0	0	0	0	0	DO2	DO1
0	0	0	0	0	0	1	0

MSB

LSB

(Relay1 = OFF, Relay2=ON)

## 2 Read status of Digital Input (function code 02)

### Query

This function is used to read the status of DI ON/OFF (1=ON, 0=OFF). The frame message contains slave device address, function field, quantity of data characters, data characters and error checking. The address of DI status start from 0000H (DI1=0000H, DI2=0001H, DI3=0002H, DI4=0003H, DI5=0004H, DI6=0005H).

Table 4.6 Example of reading DI1 to DI4 status of slave device 17.

Addr	Fun	DI start addr hi	DI start addr lo	Data num hi	DI num lo	CRC16 hi	CRC16 lo
11H	02H	00H	00H	00H	04H	7BH	59H

### Response

The response of DI status query includes address, function code, data count, data and error check. All DI status relate to one byte. The DI1 to DI4 starts from the last bit of the byte (1=ON, 0=OFF). As in Table 4.7, DI1=ON, DI2=ON, DI3=OFF and DI4=OFF.

Table 4.7 Example of response to query of DI1 to DI4 status.

Addr	Fun	Byte Count	Data	CRC16 hi	CRC16 lo
11H	02H	01H	03H	E5H	49H

### Data byte

Table 4.7 Response to query of DI1 to DI4

0	0	0	0	DI4	DI3	DI2	DI1
0	0	0	0	0	0	1	1

MSB

LSB

(Relay1 = OFF, Relay2=ON)

### 3. Read Data (function code 03)

#### Query

This function code is used to read the metering data in meter. Table 4.8 Example of reading 3 metering data U1, U2 and U3. The register address is, U1: 0110H, U2: 0111H and U3: 0112H.

Table 4.8 Query of Reading U1, U2 and U3

Addr	Fun	Data start reg hi	Data start reg lo	Data #of regs hi	Data #of regs lo	CRC16 hi	CRC16 lo
11H	03H	01H	10H	00H	03H	07H	62H

#### Response

The response includes Address of slave device, function code, data register start address, number of metering data and error check.

Table 4.9 Example of response of reading U1, U2 and U3 (U1=03E8H (100.0V), U2=03E7H(99.9V), U3=03E9H(100.1V)).

Table 4.9 Response of reading U1, U2 and U3

Addr	Fun	Byte count	Data1 hi	Data1 lo	Data2 hi	Data2 lo	Data3 hi	Data3 lo	CRC16 hi	CRC16 lo
11H	03H	06H	03H	E8H	03H	E7H	03H	E9H	FDH	9CH

### 4. Control Relay (function code 05)

#### Query

This message forces single Relay either ON or OFF. The start address of Relay is from 0000H. (Relay1= 0000H, Relay2=0001H).

The data value FF00H will set the Relay ON and the value 0000H will turn it OFF. All other values are illegal and will not affect that Relay.

Table 4.10 Control Relay query message

Addr	Fun	DO addr hi	DO addr lo	Value hi	Value lo	CRC16 hi	CRC16 lo
11H	05H	00H	00H	FFH	00H	8EH	AAH

**Response**

The normal response to the request is to retransmit back the message received after the Relay status has been altered.

Table 4.11 Response of control Relay query

Addr	Fun	DO addr hi	DO addr lo	Value hi	Value lo	CRC16 hi	CRC16 lo
11H	05H	00H	00H	FFH	00H	8EH	AAH

**5. Pre-set Multi-register (function code 05)**

**Query**

Function code 16 can be used to modify the contents of multi-register. Any meter parameter or energy data can be pre-set into its register.

Table 4.11 Example pre-setting energy data of slave device to 17807783.3kWh. As real energy data = energy data in registerX0.1kWh, the data preset into the register is 178077833. Its Hex value is 0A9D4089H. The register address is 010CH and 010DH, total 4 bytes.

Table 4.12 Preset multi-register

Addr	Fun	Data start reg hi	Data start reg lo	Data #of regs hi	Data #of regs lo	Byte count hi
11H	10H	10H	0CH	00H	02H	04H

Value hi	Value lo	Value hi	Value lo	CRC16 hi	CRC16 lo
40H	89H	0AH	9DH	A9H	89H

**Response**

The response message includes address of slave device, function code, data start register, data number and error checking.

Table 4.13 Preset multi-register

Addr	Fun	Data start reg hi	Data start reg lo	Data #of regs hi	Data #of regs lo	CRC16 hi	CRC16 lo
11H	10H	01H	0CH	00H	02H	82H	A7H

### 4.3 Data Address Table

#### Basic metering data

All the measuring data in this register area are stored in this register area and are read by using function code 03.

Table 4.14 Metering data address table

Address	Parameter	Range	Object Type	Access
0110H	Phase Voltage U1	0~65535	Word	R
0111H	Phase Voltage U2	0~65535	Word	R
0112H	Phase Voltage U3	0~65535	Word	R
0113H	Line Voltage U12	0~65535	Word	R
0114H	Line Voltage U23	0~65535	Word	R
0115H	Line Voltage U31	0~65535	Word	R
0116H	Current I1	0~65535	Word	R
0117H	Current I2	0~65535	Word	R
0118H	Current I3	0~65535	Word	R
0119H	Average phase voltage Uavg	0~65535	Word	R
011AH	Average line voltage Ulavg	0~65535	Word	R
011BH	Average current Iavg	0~65535	Word	R
011CH	Power P	-32768~32767	Integer	R
011DH	Reactive Power Q	-32768~32767	Integer	R
011EH	Apparent Power S	0~65535	Word	R
011FH	Frequency F	4400~6500	Word	R
0120H	Power factor PF	-1000~1000	Integer	R
0121H	Load nature RT	76/67/82 (L/C/R)	Word	R
0122H	Analog output 1 AO1	0~65535	Word	R
0123H	Analog output 2 AO2	0~65535	Word	R
0124H	Neutral current In	0~65535	Word	R
Energy Data (read by using function code 03, writing by using function code 16)				
010CH (Low 16 bit)	Energy Ep	0~999999999	Dword	R/W
010DH (High 16 bit)				
010EH (Low 16 bit)	Reactive energy Eq	0~999999999	Dword	R/W
010FH (High 16 bit)				

The relation between real value (Val\_r) and communication value (Val\_c)

Table 4.15 The relation between real value and communication value

Parameter	Relation	Unit
U1, U2, U3, Uavg U12 U23, U31, Uavg	$Val\_r = Val\_c \times (PT1 / PT2) / 10$	Volt
I1, I2, I3, Iavg, In	$Val\_r = Val\_c \times (CT1/5) / 1000$	Amp
P, Q, S	$Val\_r = Val\_c \times (PT1 / PT2) \times (CT1/5)$	Watt, Var, VA
PF	$Val\_r = Val\_c / 1000$	NA
F	$Val\_r = Val\_c / 100$	Hz
Load nature RT	ASCII L(4CH), C(43H), R(52H)	NA
Ep, Eq	$Val\_r = Val\_c / 10$	Kwh, Kvah
A (4~20mA)	$Val\_r = Val\_c / 1000$	mA
AO (0~1mA)	$Val\_r = Val\_c / 10000$	mA
AO (0~5V)	$Val\_r = Val\_c / 1000$	Volt

### Meter parameter area

The meter parameters are stored in this area. The register is read by using of function code 03 and write in function code 16.

Table 4.16 parameter register address table

Address	Parameter	Access	Range	Type																		
0101H	Access code	R/W	0~9999	Word																		
0102H	Address	R/W	1~255	Word																		
0103H	Baud rate	R/W	1200, 2 400, 4800, 9600, 19200	Word																		
0104H	PT1 (Low)	R/W	100~500000	Dword																		
0105H	PT1 (High)	R/W																				
0106H	PT2	R/W	100~400	Word																		
0107H	CT1	R/W	5~9999	Word																		
0108H	CT2	R/W	5	Word																		
0109H	Relay output mode	R/W	0-Latch, 1-Monmentary, 2-Alarm	Word																		
010AH	AO1 to parameter assignment	R/W	<table style="display: inline-table; border: none;"> <tr> <td>0-U1</td> <td>1-U2</td> </tr> <tr> <td>2-U3</td> <td>3-U12</td> </tr> <tr> <td>4-U23</td> <td>5-U31</td> </tr> <tr> <td>6-I1</td> <td>7-I2</td> </tr> <tr> <td>8-I3</td> <td>9-Uavg</td> </tr> <tr> <td>10-Ulavg</td> <td>11-lavg</td> </tr> <tr> <td>12-P</td> <td>13-Q</td> </tr> <tr> <td>14-S</td> <td>15-F</td> </tr> <tr> <td>16-PF</td> <td></td> </tr> </table>	0-U1	1-U2	2-U3	3-U12	4-U23	5-U31	6-I1	7-I2	8-I3	9-Uavg	10-Ulavg	11-lavg	12-P	13-Q	14-S	15-F	16-PF		Word
0-U1	1-U2																					
2-U3	3-U12																					
4-U23	5-U31																					
6-I1	7-I2																					
8-I3	9-Uavg																					
10-Ulavg	11-lavg																					
12-P	13-Q																					
14-S	15-F																					
16-PF																						
010BH	AO2 to parameter	R/W	Same as AO1	Word																		
0130H	LCD Back Light Time	R/W	0~120	Word																		

### Alarm data

Alarm related parameter and data store in this area. Function code 03 and 16 are used to read and write data respectively.

Table 4.17 Alarm parameter and data

Address	Parameters	Access	Range	Data Type
0200H	Wiring mode	R/W	0~3 phase 4 wire,1~3 phase 3 wire Integer direct connection, 2~3 phase 3 wire connection with 3PTs	Integer
0201H	Alarm parameter	R/W	0~18	Integer
0202H	Alarm limit value	R/W	-32768~32767	Integer
0203H	Alarm time	R/W	0~255	Integer
0204H	Inequation Sign	R/W	0:<limit value, 1:> limit value	Integer
0205H	Alarm ralate RO	R/W	0-RO1, 1-RO2, 2-RO1 and RO2	Integer

### Digital Input (DI)

The Digital Input status are read in this area. Function code 02 is used to read the register

Table 4.18 Digital input status

Address	Parameters	Range	Data Type	Access
0000H	DI1	1 = ON, 0 = OFF	Bit	R/W
0001H	DI2	1 = ON, 0 = OFF	Bit	R/W
0002H	DI3	1 = ON, 0 = OFF	Bit	R/W
0003H	DI4	1 = ON, 0 = OFF	Bit	R/W
0004H	DI5	1 = ON, 0 = OFF	Bit	R/W
0005H	DI6	1 = ON, 0 = OFF	Bit	R/W

### Relay status

The relay status register are in this area. Function code 01 and 05 are used to read the register and force the relay.

Table 4.19 Relay output address table

Address	Parameters	Range	Data Type	Access
0000H	Relay 1	1 = ON, 0 = OFF	Bit	R/W
0001H	Relay 2	1 = ON, 0 = OFF	Bit	R/W

**Note:**

1. Object type: Bit-binary bit, Word-unsigned integer of 16 bit, Integer-Sign integer of 16 bit, Dwordunsigned integer of 32 bit
2. Type of Access: R-Read only, Digital input Relay statue and Data are read by using of function code 02, 01 and 03 respectively. R/W-Read and Write, Data is written by using function code 16 and control command is written by using function code 05. Writing to read only field is forbidden.
3. Energy data is represented in 32 bit. Both high 16 bit and low 16 bit have successive address alone. The high 16 bit data should be multiplied by 65536 and plus low 16 bit data to get the energy data in master software. The unit is 0.1kwh or 0.1kvarh. It will be clear to zero and start again when energy data accumulate to 1x109 kWh (kVarh). The energy register can be cleared or preset over communication.

# *EV/DV300 Series Power Meter*

## Appendix

---

**Appendix A Technical Data and Specifications**

**Appendix B Ordering Information**



## Appendix

### Appendix A Technical Data and Specification

#### Input ratings

Voltage Input		
Voltage rating	-100V	100Vac nominal F.S.input, VIn with 20% overrange 100Vac nominal F.S.input, VIl with 20% overrange
	-400V	400Vac nominal F.S.input, VIn with 20% overrange 400Vac nominal F.S.input, VIl with 20% overrange
Frequency range		45~65Hz
Overload		2 times for continue, 2500VAC/1sec (none recurrence)
Voltage range over PT		500kV highest at primary side
PT burden		<0.2VA
Measuring		True-RMS

Current input		
Current rating	5Amp 1Amp Option	5Amp AC nominal F.S.input, with 20% over range
Current range over CT		10000A highest at primary side 9999A
Overload		10A/continue, 100A/1sec (None recurrence)
CT burden		<0.5VA
Measuring		True-RMS

**Accuracy**

Parameters	Accuracy	Resolution
Voltage	0.5%	0.1%
Current	0.5%	0.02%
Power	1.0%	0.1%
Reactive Power	1.0%	0.1%
Apparent Power	1.0%	0.1%
Power Factor	1.0%	0.1%
Frequency	0.5%	0.01Hz
Energy	1.0%	0.1kWh
Reactive Energy	1.0%	0.1kvarh
Drift with temp.	< 100ppm/°C	
Stability	0.1%0 /year	

Relay output (RO)	
Output form	Mechanical Contact
Contact Resistance	100m ohm@1A, Initial
Max break voltage	250Vac, 30Vdc
Max break current	5A
Max isolate voltage	4000Vac rms

Digital output (DO)	
Output form	Photo-MOS, NO
Optical Isolation	4000Vac rms
Max Positive Voltage	40Vdc
Max Positive Current	30mA
Max Reverse Voltage	6Vdc

Analog output (AO)		
Output Range	4~20mA or 0~1mA or 0~5V	
Resolution	12bit	
Max Load	4~20mA	Max load resistance: 500Ω
	0~1mA	Max load resistance: 10kΩ
	0~5V	Max load current: 20mA

24Vdc power supply (PO)	
Voltage Output range	24V(±10%)
Power Rating	2W
Isolate Voltage	1000Vdc

Standard		
Measuring	IEC 61036 Class1	ANSI C12.16 Class10
Environmental	IEC 60068-2	
Safety	IEC 61010	
EMC	IEC 61000-4/2-3-4-5-6-8-11	
Dimension	DIN 43700	

24Vdc power supply (PO)	
Dimension (mm)	96×96×60 (Cut OUT 92×92)
Protection	IP54 (Front), IP20 (Cover)
Weight (g)	500g
Temperature	-25°C~+70°C
Humidity	0~95% Non-condensing
Power Supply	85~264Vac or 100V~280Vdc
Power Consumption	2.5W

## Appendix B Ordering Information



Fig 5-1 EV300 ordering information

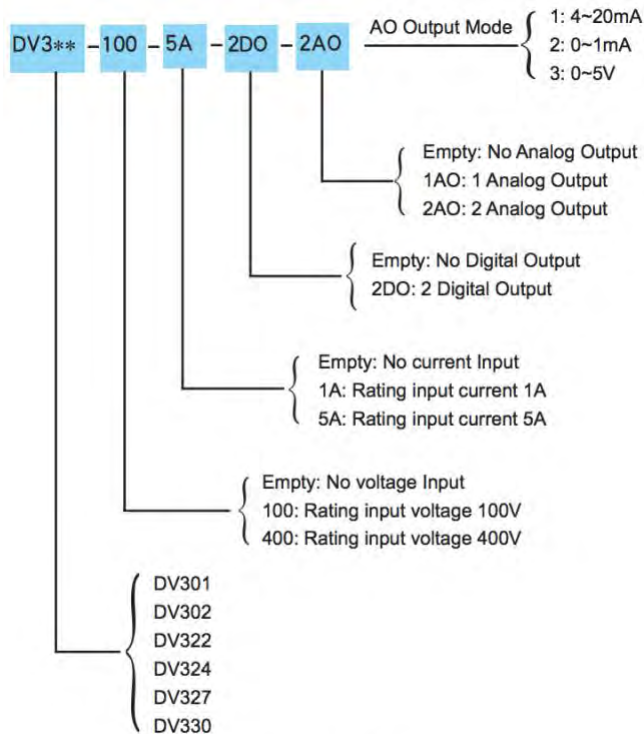

Fig 5-2 DV300 ordering information