

Application

The CP-9301 and CP-9302 electronic actuator drives process a variable input signal from a controller to provide proportional control of an electric gear train actuator. The CP-9301 is preset at the factory for voltage input. The CP-9302 is factory preset for current input and has additional wiring for connection to an override switch, for those applications requiring an external override of the input signal. These drives are equipped with built-in jumpers and adjustable potentiometers, so that the type of input signal, deadband, input span, and start point may be reset in the field when necessary.

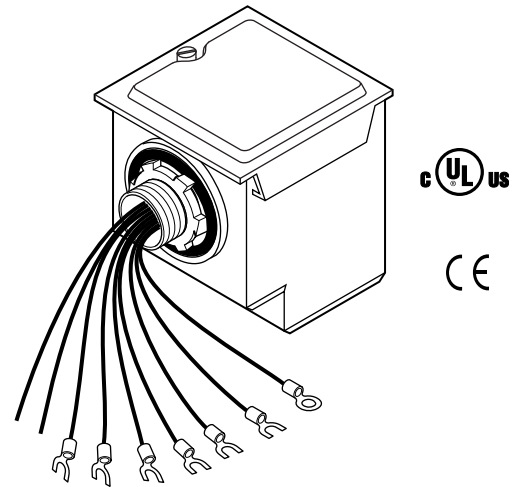

Features

- Mounts directly onto Schneider Electric proportional, electric, gear train actuators.
- Power is supplied directly from the actuator.
- May be used with all gear train actuator voltages and frequencies.
- Jumpers for selecting either voltage or current input, as well as 3% or 5% deadband.
- Adjustable span and start point potentiometers.

Applicable Literature

- Environmental Controls Cross-Reference Guide, F-23638
- Environmental Controls Reference Manual, F-21683
- Environmental Controls Application Manual, F-21335
- Pneumatic Products Catalog, F-27383
- MP-3XX Series, MP-4XX Series, MP-2XXX Series, and MP-4XXX Series Reversible and Proportional Electric Actuators General Instructions, F-15479
- MC-9000, MF-9000, and MP-9000 High Torque, Oil-Submerged Actuators General Instructions, F-11331

SPECIFICATIONS

Mounting: Directly to an actuator. The drive may be mounted on either the left or right side of the actuator, in a conduit opening adjacent to the low voltage wiring compartment.

Case: Injection molded plastic with stamped aluminum cover.

Inputs — Voltage and Current

Input: Refer to Table-1 and Adjustments Section.

Input Span Adjustment: Refer to Table-1 and Adjustments Section.

Start Point Adjustment: Refer to Table-1 and Adjustments Section.

Input Impedance:

Voltage Input, Greater than 10,000 ohms.

Current Input, 250 ohms.

Power Supply: Power shall be supplied directly from the shading coil windings provided on the shaded pole reversible motor of the gear train actuator (less than 30 Vac).

Outputs

Connections: Color-coded leads with crimped screw terminal connectors. Purge override (input signal override) leads are color-coded pigtailed.

Shading Coil Triac Output: 1.2 A RMS.

Deadband: Refer to Table-1 and Adjustments Section.

Environment

Ambient Temperature Limits:

Shipping & Storage, -40 to 160 °F (-40 to 71 °C).

Operating, -40 to 136 °F (-40 to 58 °C).

Humidity: 5 to 95% relative humidity, non-condensing.

Locations: NEMA Type 4; IEC IP56.

Agency Listings

UL Listed:

UL 873 (File #E9429 Category Temperature Indicating and Regulating Equipment).

Certified for use in Canada by Underwriters Laboratories.

European Community: EMC Directive 89/336/EEC.

Table-1 Model Chart.

Part Number	Input Signal Override	Factory Presets				Jumper Settings		Potentiometer Adjustment Ranges	
		Input Signal	Deadband	Start Point	Input Span	Input Signal	Deadband	Input Span	Start Point
CP-9301	Not Available	Voltage (6 to 9 Vdc)	3% of Input Span	6 Vdc	3 Vdc	• Voltage or Current	• 3% or 5% of Input Span	• 3.0 to 16.5 Vdc or • 8 to 16 mAdc	• 0 to 10 Vdc or • 2 to 16 mAdc
CP-9302	Available (Use is Optional)	Current (4 to 20 mAdc)		4 mAdc	16 mAdc				

Table-2 Typical Actuators.

Actuator Series	Power		Torque		Stroke Degrees	Spring Return	Internal Transformer ^a
	Vac (60 Hz)	Amp	Lb-in.	N-m			
MP-2113-500	24	2.2	50	5.6	180	—	No
MP-361	24	2.5	50	5.6	180	CW	No
MP-371	24	2.5	50	5.6	180	CCW	No
MP-381	24	2.5	220	24.9	180	—	No
MP-9713	24	4.0	800	90.3	180	—	No
MP-2150-500	120	0.5	50	5.6	180	—	Yes
MP-465	120	0.5	50	5.6	180	CW	Yes
MP-475	120	0.5	50	5.6	180	CCW	Yes

^a Units with a "-2" suffix, e.g. MP-XXXX-XXX-2-X, include a built-in transformer (used for Schneider Electric Microtherm[®] or with AE-504) with secondary leads wired externally to terminals 7 (Blue, 12 Vac) and 8 (Red, 24 Vac) of the actuator.

Caution: When using the CP-9301 or CP-9302 with actuators containing an *internal transformer*, disconnect and tape off the red and blue leads before installing and powering the device. *Failure to do so can result in damage to the actuator drive.*

Note: Models prior to "-2" suffix had transformer wired directly to potentiometer. To disconnect the transformer, remove the back plate of the actuator, then disconnect and tape the transformer leads.

Table-2 Typical Actuators. (Continued)

Actuator Series	Power		Torque		Stroke Degrees	Spring Return	Internal Transformer ^a
	Vac (60 Hz)	Amp	Lb-in.	N-m			
MP-483	120	0.5	220	24.9	90	—	Yes
MP-485	120	0.5	220	24.9	180	—	Yes
MP-495	120	0.95	450	50.8	180	—	Yes
MP-9750	120	0.9	800	90.3	180	—	Yes
MP-4651	240	0.25	50	5.6	180	CW	Yes
MP-4851	240	0.25	220	24.9	180	—	Yes

^a Units with a "-2" suffix, e.g. MP-XXXX-XXX-2-X, include a built-in transformer (used for Schneider Electric Microtherm® or with AE-504) with secondary leads wired externally to terminals 7 (Blue, 12 Vac) and 8 (Red, 24 Vac) of the actuator.

Caution: When using the CP-9301 or CP-9302 with actuators containing an *internal transformer*, disconnect and tape off the red and blue leads before installing and powering the device. *Failure to do so can result in damage to the actuator drive.*

Note: Models prior to "-2" suffix had transformer wired directly to potentiometer. To disconnect the transformer, remove the back plate of the actuator, then disconnect and tape the transformer leads.

ACCESSORIES

None

Tools

See tools listed in Requirements section.

TYPICAL APPLICATIONS (wiring diagrams)

Refer to Figure-1 for a service application wiring diagram showing the connections between a CP-9301 or CP-9302 drive and an MP-3XX, MP-4XX, MP-21XX, or MP-97XX series actuator. Figure-2, Figure-3, and Figure-4 diagram the connection of multiple actuators.

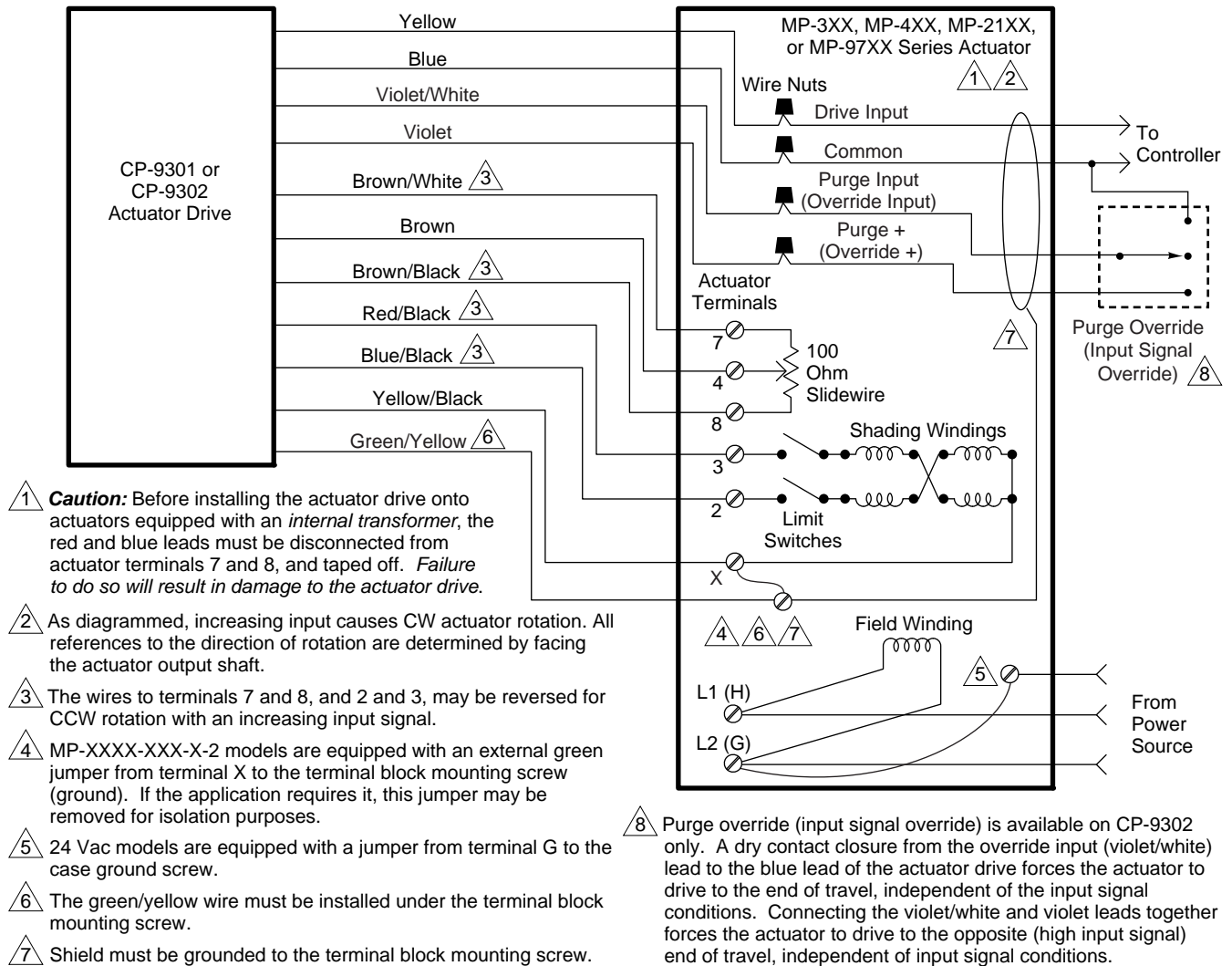

Figure-1 Service Application Wiring Diagram.

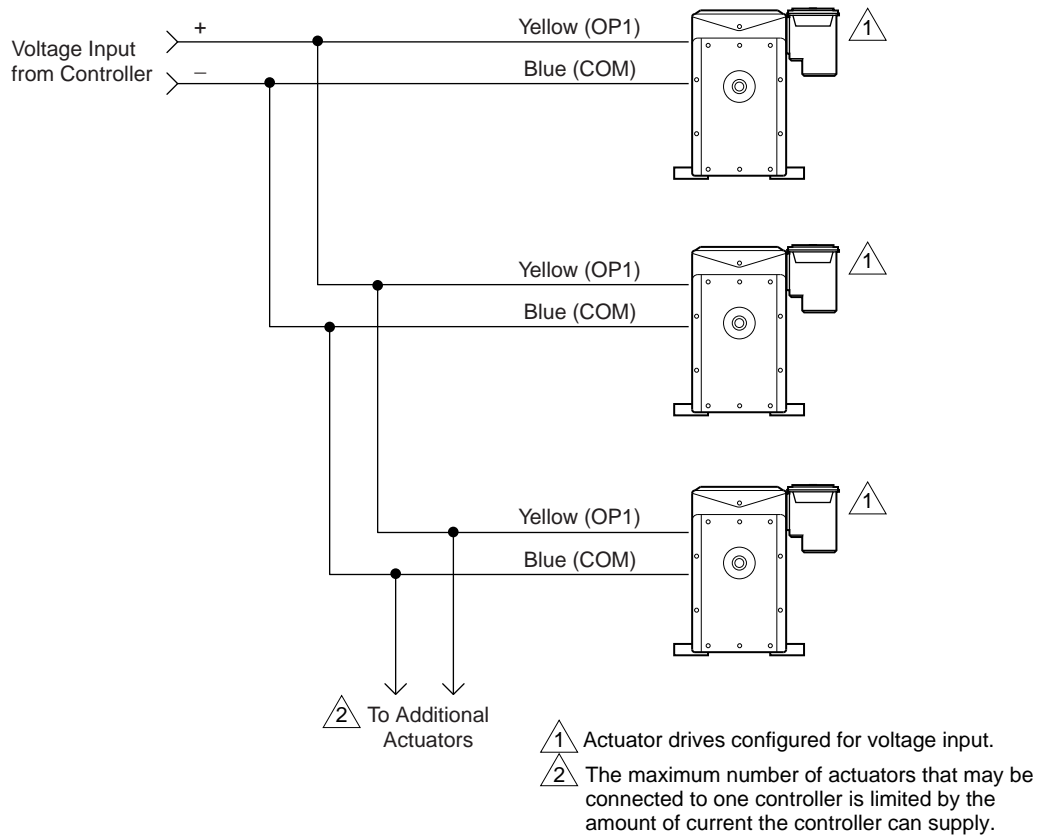

Figure-2 Typical Control Wiring for Multiple Actuators with Drives Configured for Voltage Input.

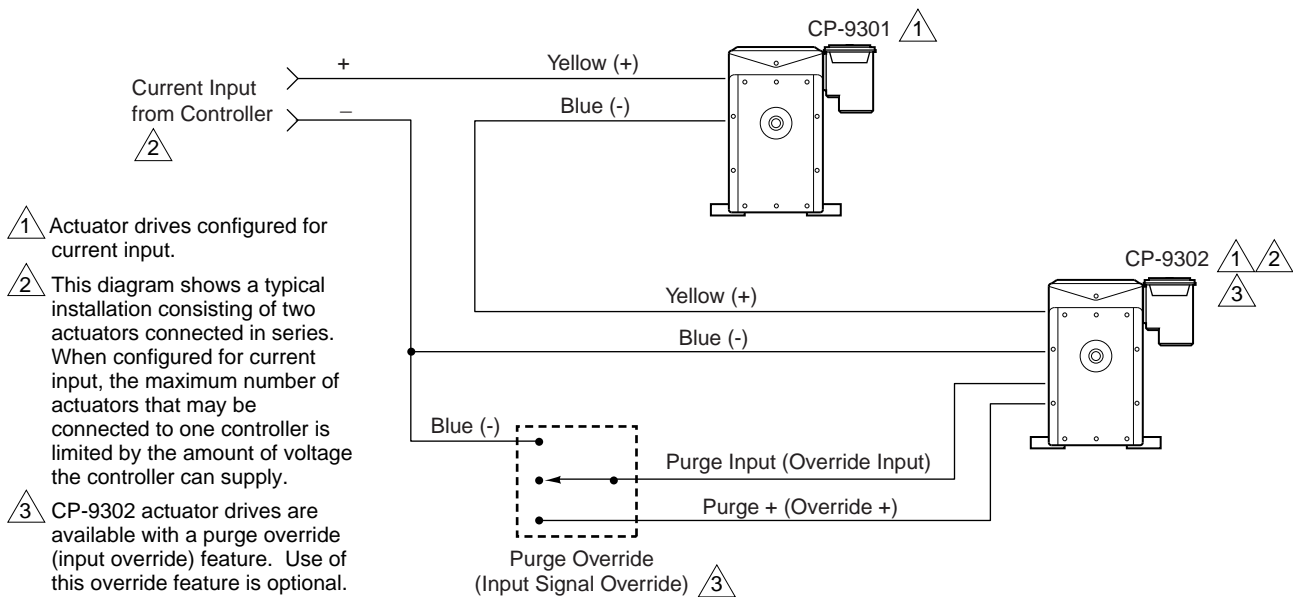

Figure-3 Typical Control Wiring for Two Actuators with Drives Configured for Current Input.

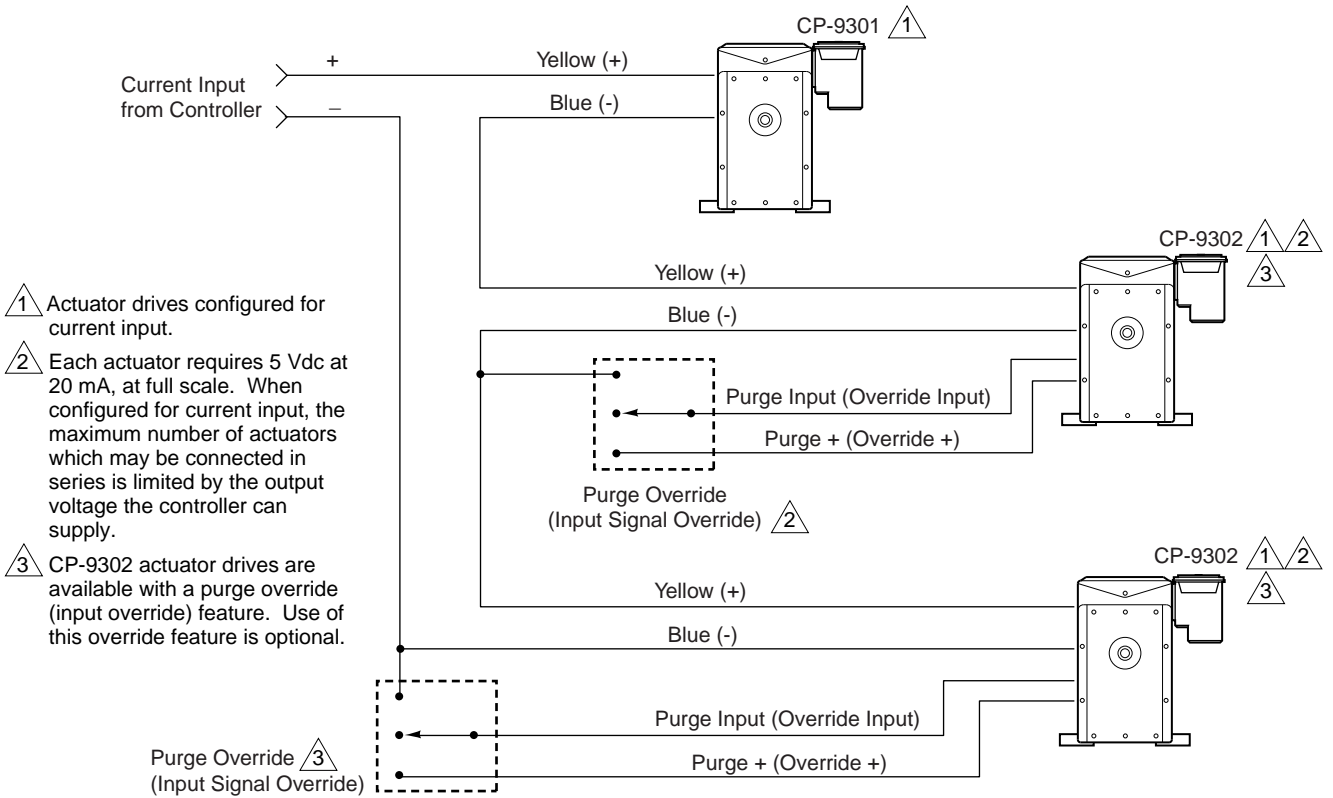

Figure-4 Typical Control Wiring for Three or More Actuators with Drives Configured for Current Input.

INSTALLATION

Inspection

Inspect the package for damage. If damaged, notify the appropriate carrier immediately. If undamaged, open the package and inspect the device for obvious damage. Return damaged products.

Requirements

- Tools (not provided):
 - Appropriate screwdriver
 - Slip joint pliers
 - Digital Volt-ohm Meter (DVM)
 - Suitable voltage signal source (for voltage start point and input span adjustment)
 - Milliamp meter
 - Suitable current signal source (for current start point and input span adjustment)
- Training: Installer must be a qualified, experienced technician
- Other accessories as required to install the actuator
- Wiring diagrams

Warning:

- Electrical shock hazard! Disconnect power before installation to prevent electrical shock or equipment damage.
 - Make all connections in accordance with the electrical wiring diagram and in accordance with national and local electrical codes. Use copper conductors that are suitable for 105°C.
-

Caution:

- Do not exceed the ratings of the device(s).
 - Static charges produce voltages high enough to damage the electronic components. Follow static electricity precautions when installing or servicing the device(s).
 - Avoid locations where excessive oil, dust, moisture, corrosive fumes or vibration, or an explosive atmosphere is present.
-

Mounting

The drive may be mounted on either the left or right side of the actuator, in a conduit opening adjacent to the low voltage wiring compartment. Mount the drive onto an actuator as follows:

1. Remove the cover from the actuator, to expose its power wiring compartment and low voltage wiring compartment. Note that each side of the actuator casing features two 1/2" knockouts which provide access to these two compartments.
2. Determine on which side of the actuator the drive is to be mounted (Figure-5, Figure-6, and Figure-10). Remove the knockout on that side, adjacent to the low voltage wiring compartment.
3. Temporarily remove the locknut from the drive. Verify that the O-ring (Figure-6 and Figure-10) is fully seated on the drive's casing, and insert the drive's 1/2" conduit connector into the opening from which the knockout was removed.

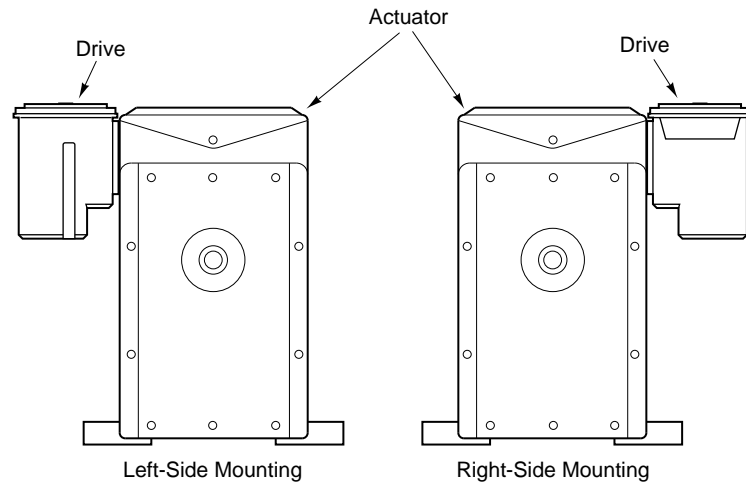

Figure-5 Mounting Position of Drive on Actuator.

4. Secure the drive to the actuator with the locknut removed in step 3. Refer to Figure-6.
5. Connect the drive to the actuator according to the instructions in the Wiring section.

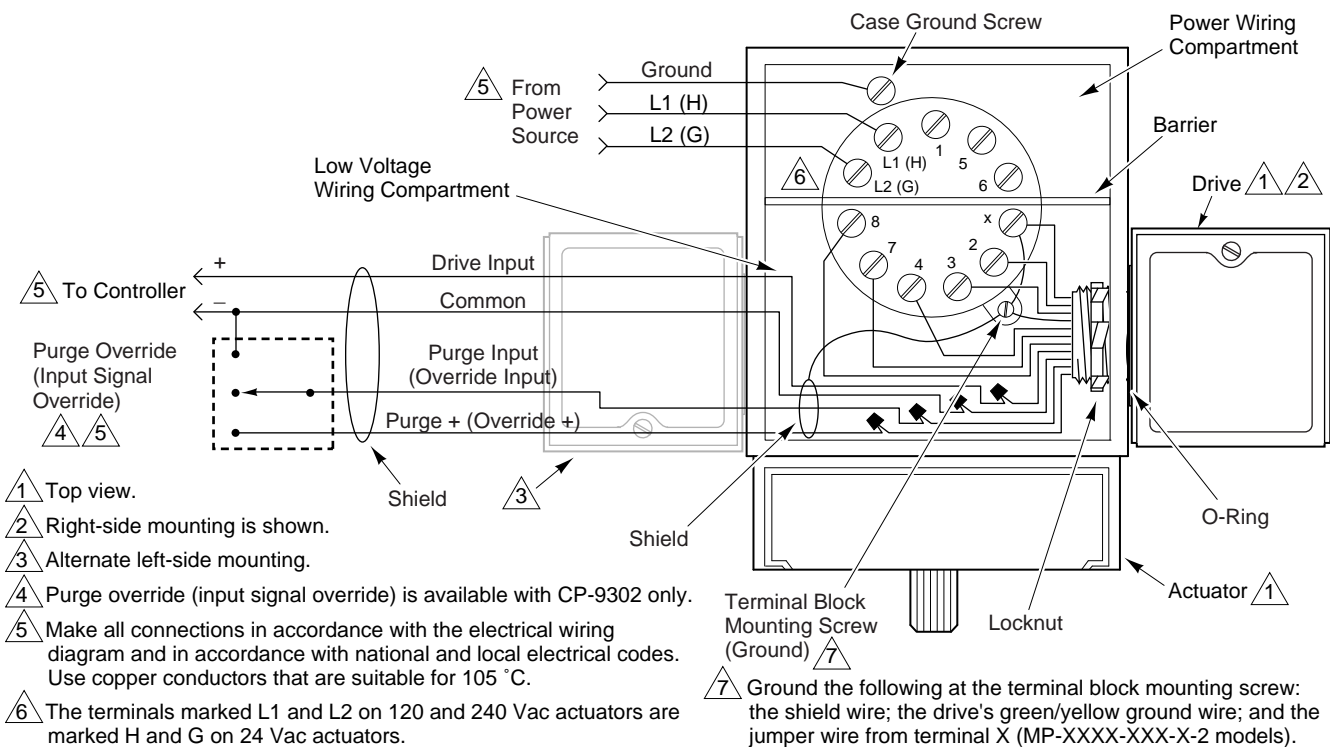

Figure-6 Actuator/Drive Wiring and Mounting Arrangement.

WIRING

Power Wiring

The power for the drive is supplied directly from the shading coil windings of the gear train actuator onto which the drive is mounted. Refer to Figure-7 or Figure-8 for an installation wiring diagram.

Power wiring instructions for the gear train actuator may be found in **MP-3XX Series, MP-4XX Series, MP-2XXX Series, and MP-4XXX Series Reversible and Proportional Electric Actuators General Instructions, F-15479**, or in **MC-9000, MF-9000, and MP-9000 High Torque, Oil-Submerged Actuators General Instructions, F-11331**.

Input Wiring

The drive's two input leads, which must be connected to the controller, are color-coded blue (common) and yellow (drive input). Refer to Figure-7 if the drive is configured for voltage input (factory preset for CP-9301), and to Figure-8 when the input jumper is positioned for current input (factory preset for CP-9302). The connections to the low voltage wiring compartment may be per Class 2 circuit requirements.

Use 18 to 22 gage, two-conductor (CP-9301) or four-conductor (CP-9302), shielded cable for runs of up to 1000 ft. (305 m) between the controller and the actuator. Use larger-sized leads for longer runs.

Caution:

- Before installing the CP-9301 or CP-9302 onto actuators equipped with an *internal transformer*, disconnect the red and blue leads from actuator terminals 7 and 8, and tape off. *Failure to do so will result in damage to the actuator drive.*
- Ground the shielding on the signal leads at one end only, using the actuator's terminal block mounting screw. Grounding the shielding at both ends could create a potential difference in the shielding, which may affect the signal carried by the leads.

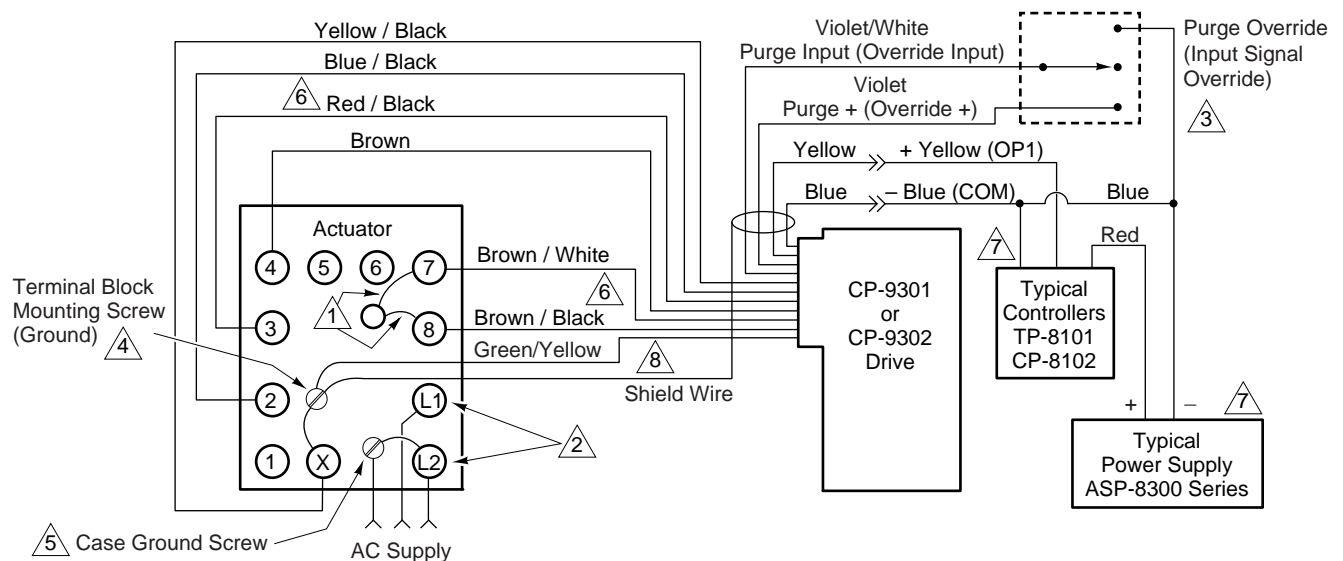

- 1** **Caution:** Before installing the CP-9301 or CP-9302 onto actuators equipped with an *internal transformer*, disconnect the red and blue leads from actuator terminals 7 and 8, and tape off. *Failure to do so will result in damage to the actuator drive.*
- 2** The L1 and L2 terminals are marked H and G on 24Vac actuators.
- 3** Purge override (input signal override) is available on CP-9302 only. A dry contact closure from the purge (override) input lead (violet/white) to the blue lead of the actuator drive forces the actuator to drive to the end of travel, independent of the input signal conditions. Connecting the violet/white and violet leads together forces the actuator to drive to the opposite (high input signal) end of travel, independent of input signal conditions. If the purge override (input signal override) function is not used, be sure to tape off the violet/white and violet leads.

- 4** MP-XXXX-XXX-X-2 models are equipped with an external green jumper from terminal X to the terminal block mounting screw (ground). If the application requires it, this jumper may be removed for isolation purposes.
- 5** 24 Vac models are equipped with a jumper from terminal G to the case ground screw.
- 6** As diagrammed, increasing input causes CW actuator rotation. For CCW rotation with an increasing input signal, reverse blue/black and red/black leads, and reverse brown/black and brown/white leads. All references to the direction of rotation are determined by facing the actuator output shaft.
- 7** Supplied by customer.
- 8** Ground the shield wire and the drive's green/yellow ground wire at the actuator's terminal block mounting screw.

Figure-7 Installation Wiring Diagram for Voltage Inputs.

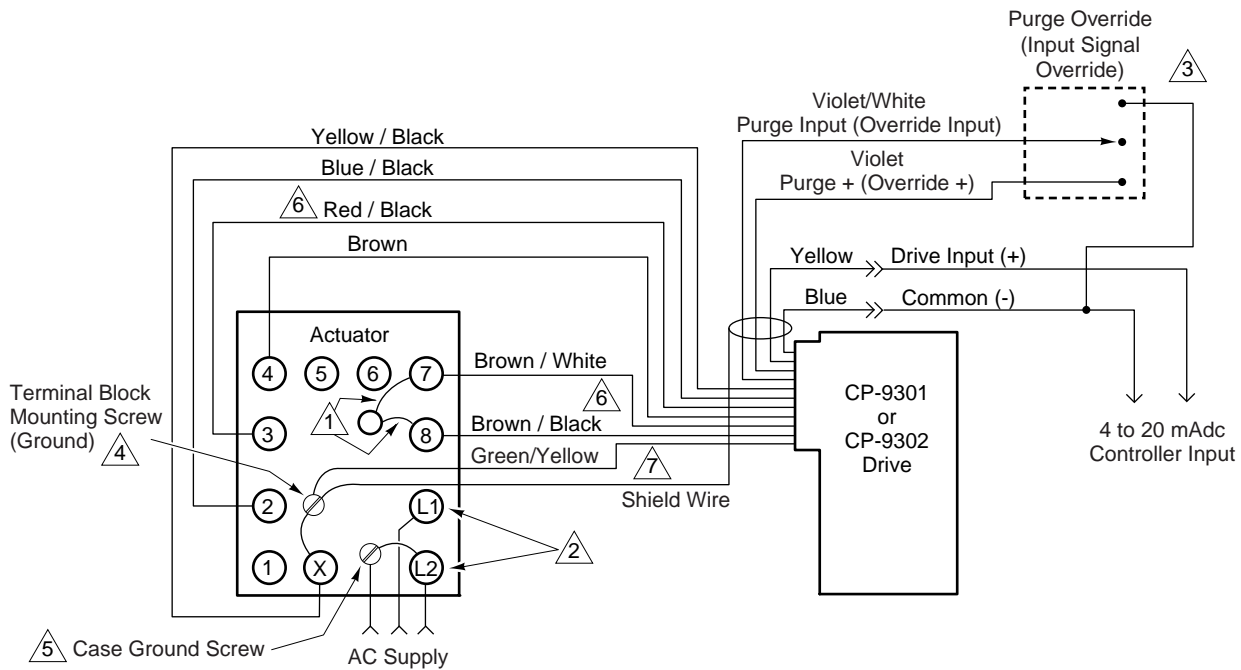

⚠ **Caution:** Before installing the CP-9301 or CP-9302 onto actuators equipped with an *internal transformer*, disconnect the red and blue leads from actuator terminals 7 and 8, and tape off. *Failure to do so will result in damage to the actuator drive.*

⚠ The L1 and L2 terminals are marked H and G on 24Vac actuators.

⚠ Purge override (input signal override) is available on CP-9302 only. A dry contact closure from the purge (override) input lead (violet/white) to the blue lead of the actuator drive forces the actuator to drive to the end of travel, independent of the input signal conditions. Connecting the violet/white and violet leads together forces the actuator to drive to the opposite (high input signal) end of travel, independent of input signal conditions. If the purge override (input signal override) function is not used, be sure to tape off the violet/white and violet leads.

⚠ MP-XXXX-XXX-X-2 models are equipped with an external green jumper from terminal X to the terminal block mounting screw (ground). If the application requires it, this jumper may be removed for isolation purposes.

⚠ 24 Vac models are equipped with a jumper from terminal G to the case ground screw.

⚠ As diagrammed, increasing input causes CW actuator rotation. For CCW rotation with an increasing input signal, reverse blue/black and red/black leads, and reverse brown/black and brown/white leads. All references to the direction of rotation are determined by facing the actuator output shaft.

⚠ Ground the shield wire and the drive's green/yellow ground wire at the actuator's terminal block mounting screw.

Figure-8 Installation Wiring Diagram for Current Inputs.

ADJUSTMENTS

Voltage Input Adjustments

The CP-9301 and CP-9302 actuator drives feature one jumper for selecting voltage or current input, a second jumper for selecting 3% or 5% deadband, and potentiometers for adjusting the input span and start point. The CP-9301 is preset at the factory for voltage input, and the CP-9302 is preset for current input (Table-1). When necessary, these factory presets may be changed according to the procedures in this section.

When a CP-9301 has been left at its factory presets, the settings detailed in Table-1 apply. If a CP-9301 requires adjustments to its deadband, startpoint, or input span, or if a CP-9302 is to be reconfigured for voltage input, make adjustments according to the following:

Caution:

- Do not apply a current source input to a CP-9301 or CP-9302 actuator drive that is configured for voltage input (factory setting). Doing so may damage the drive.
 - Static charges produce voltages high enough to damage the electronic components. Follow static electricity precautions when servicing the device(s).
-

1. Turn off the controller signal to the drive's input.
2. Turn off power to the actuator.
3. Remove the screw that secures the cover to the drive, then remove the cover. This provides access to the start point and input span adjustment potentiometers, as well as the input and deadband jumpers (Figure-9).

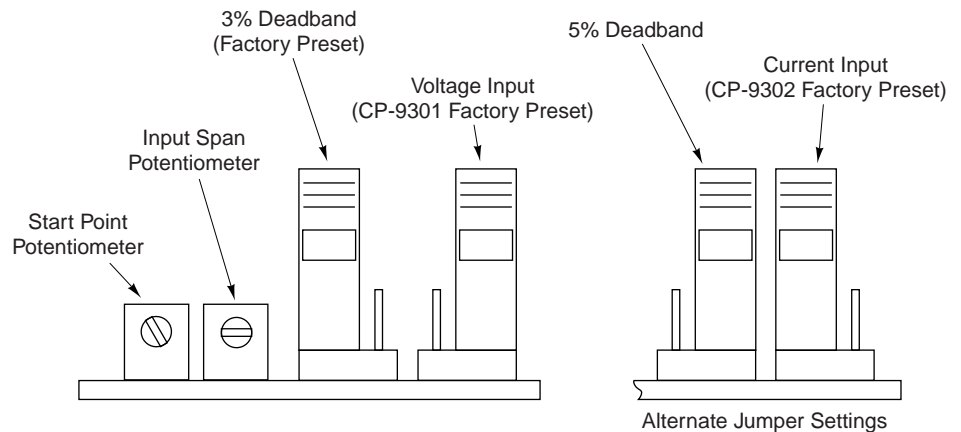

Figure-9 Input and Deadband Jumpers, and Input Span and Start Point Potentiometers.

4. Disconnect the drive's yellow and blue leads from the controller.
5. When reconfiguring a CP-9302 for voltage input, reposition the input jumper to the voltage input setting, as shown in Figure-9.
6. Connect the leads of a suitable voltage signal source (voltage calibrator) to the appropriate drive leads.
7. Connect a DVM to the yellow (drive input) and blue (COM) leads of the drive.
8. Apply power to the actuator, then turn on the voltage signal source.
9. If desired, reset the deadband by repositioning the deadband jumper.
10. Adjust the voltage signal source (voltage calibrator) until the DVM reading equals the desired start point voltage (0 to 10 Vdc).
11. With the desired start point voltage applied, adjust the start point potentiometer, using a small screwdriver, so that the actuator shaft *just reaches the start point*.

12. Determine the finish point of the actuator by adding the desired voltage span to the start point voltage. The finish point is the voltage that causes the actuator to just reach its rotational limit. Adjust the voltage signal source (voltage calibrator) until the DVM reading equals the calculated finish point voltage.
13. With the finish point voltage applied, adjust the input span potentiometer, using a small screwdriver, so that the actuator shaft *just reaches its rotational limit*.

Note: Occasionally, an adjustment to the input span setting results in a change to the start point setting, due to a small interaction between these two settings. After adjusting the input span potentiometer, ensure that both settings meet requirements by repeating steps 10 through 13, as necessary.

14. Turn off the voltage input signal to the drive and turn off power to the actuator. Then, reconnect the drive's leads to the controller.
15. Reinstall the cover onto the drive and secure it with the screw removed in step 3.
16. Reapply power to the actuator, then turn on the controller signal to the drive's voltage input.

Current Input Adjustments

When a CP-9302 has been left at its factory presets, the settings detailed in Table-1 apply. If a CP-9302 requires adjustments to its deadband, startpoint, or input span, or if a CP-9301 is to be reconfigured for current input, make adjustments according to the following:

Caution:

- Do not apply a voltage source input to a CP-9301 or CP-9302 actuator drive that is configured for current input. Doing so may damage the drive.
 - Static charges produce voltages high enough to damage the electronic components. Follow static electricity precautions when servicing the device(s).
-

1. Turn off the controller signal to the drive's current input.
2. Turn off power to the actuator.
3. Remove the screw that secures the cover to the drive, then remove the cover. This provides access to the start point and input span adjustment potentiometers, as well as the input and deadband jumpers (Figure-9).
4. Disconnect the drive's yellow and blue leads from the controller.
5. When reconfiguring a CP-9301 for current input, reposition the input jumper to the current input setting, as shown in Figure-9.
6. Connect a digital mA meter in series with the current signal source (current calibrator) by connecting the meter's red lead to the signal source's "+" output, and the meter's black lead to the drive's yellow lead.
7. Connect the drive's blue (common [-]) lead to the corresponding lead of a suitable current signal source (current calibrator).
8. Apply power to the actuator, then turn on the current signal source (current calibrator).
9. If desired, reset the deadband by repositioning the deadband jumper.
10. Adjust the current signal source (current calibrator) until the mA meter reading equals the desired start point current (2 to 16 mAdc).
11. With the desired start point current applied, adjust the start point potentiometer, using a small screwdriver, so that the actuator shaft *just reaches the start point*.
12. Determine the finish point of the actuator by adding the desired current span to the start point current. The finish point is the current that causes the actuator to just reach its rotational limit. Adjust the current signal source (current calibrator) until the mA meter reading equals the calculated finish point current.
13. With the finish point current applied, adjust the input span potentiometer, using a small screwdriver, so that the actuator shaft *just reaches its rotational limit*.

Note: Occasionally, an adjustment to the input span setting results in a change to the start point setting, due to a small interaction between these two settings. After adjusting the input span potentiometer, ensure that both settings meet requirements by repeating steps 10 through 13, as necessary.

14. Turn off the current input signal to the drive and turn off power to the actuator. Then, reconnect the drive's leads to the controller.
15. Reinstall the cover onto the drive and secure it with the screw removed in step 3.
16. Reapply power to the actuator, then turn on the controller signal to the drive's current input.

CHECKOUT

After the entire system has been installed and the actuator has been powered up, the following checks can be made to verify proper system operation.

Positioning with Controller

If the sensed media is within the controller's throttling range, the actuator can be positioned by adjusting the controller setpoint up and down. Check for correct operation of the actuator (valve or damper) while it is being stroked. Use a DVM or mA meter to verify the actual signal that is applied.

Manual Positioning

A manual positioning test of the drive may be conducted by performing the start point and input span adjustment procedure. Where the procedure calls for adjustments to be made to the potentiometers, simply verify that the actuator shaft is *just* reaching the start point or is *just* reaching its limit, as applicable.

MAINTENANCE

The drive requires no maintenance.

Regular maintenance of the total system is recommended to assure sustained, optimum performance.

FIELD REPAIR

None. Replace an inoperative drive with a functional unit.

DIMENSIONAL DATA

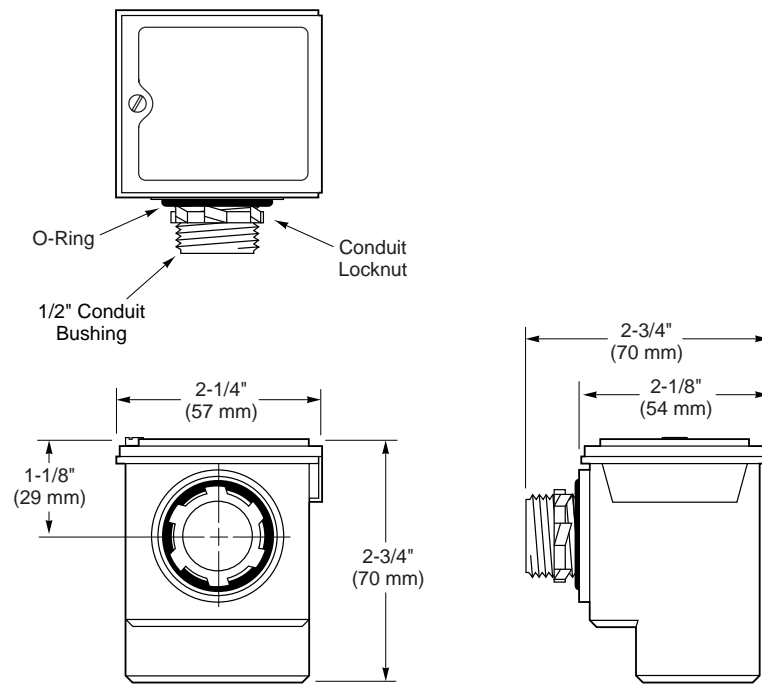

Figure-10 Mounting Dimensions of CP-9301 and CP-9302 Electronic Actuator Drives.