



INNOVATIONS IN FORCE MEASUREMENT

Dillon/Quality Plus, Inc.

3201 Corte Malpaso Unit 311 Camarillo, CA. 93012

Tel: 800-225-6543 Fax: 805-388-2735

www.dqplus.com E-mail: sales@dqplus.com

Distributor / Sales / Service / Calibration

Precision Wheel Test Stand

HV-110S with Distance Meter
HV-110 without Distance Meter
HV-110L Long Stroke Available

Distance Meter Specifications	
Display	Push button for inch/mm, zero set and on/off
Resolution	0.0005"/0.01mm
Accuracy	0.1% of reading or 0.005"/0.1mm, whichever is greater

- Hand wheel design provides a high degree of precise control
- One stand for both compression (push) and tension (pull) tests
- Gauge remains in place when hand wheel is released
- HV-110 Stroke: 13.75" Max clearance 9" (with extender 14")
- HV-110L Stroke: 21.5" Max clearance 16.8" (with extender 21.8")
- Capacity 110 lbs
- Optional digital distance meter

Model HV-110S/HV-110 are compact test stands with a maximum capacity of 110 lbs. The handwheel offers precise movement that is ideal for applications requiring relatively consistent speed and maximum gauge control. The gauge remains in position when the wheel is released which allows the user to easily change samples between tests. Hand wheel operation provides repeatable test results from sample to sample. The HV-110S/HV-110 accommodate any of the standard range Imada force gauges.

AP-002 Adapter Plate is available to mount most other force gauges to IMADA test stands.

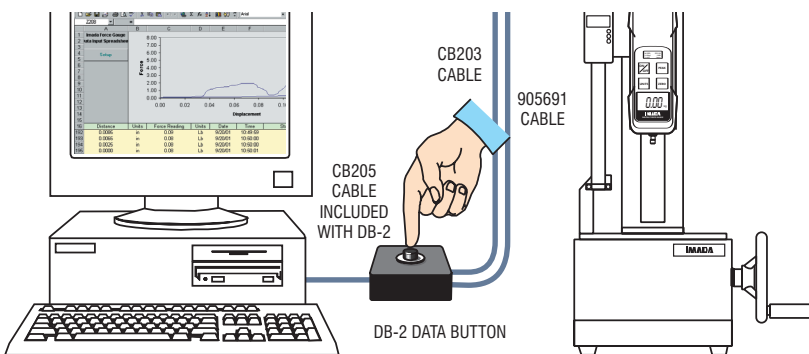

Optional Data Acquisition Kit

Collect both force and displacement data for analysis with SW-2 Imada data acquisition software and DB-2 data button.

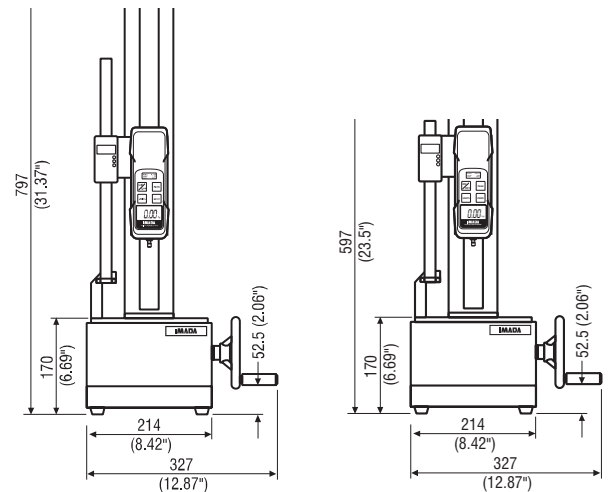

HV-110L

HV-110

Force gauge and distance meter sold separately. Specifications subject to change without notice.