

## USER INSTRUCTIONS

# Programmable 2-wire Transmitter

for Pt100 and Pt1000 Input

## APAQ C130<sup>RTD</sup>



The user instruction must be read prior to adjustment and/or installation.  
All information subject to change without notice.

### MEASURE OF SUCCESS



# INOR



This product should not be mixed with other kind of scrap, after usage.  
It should be handled as an electronic/electric device.

© INOR 06/2025 - 4008101002 - MA APAQ C130 RTD RD

## GENERAL INFORMATION

APAQ C130<sup>RTD</sup> is a low cost, non-isolated, easy-to-use 2-wire temperature transmitter for Pt100 and Pt1000 input, intended to be used in industrial environment.

The transmitter is configured from a mobile device via NFC communication, by using the app INOR Connect. Inor Connect is available for free download on App Store, Google Play Store and Huawei AppGallery.

### DATA (short form)

<b>Input</b>	2-, 3-, 4-wire connection
Pt100 (IEC 60751, $\alpha=0.00385$ )	-200 to +850 °C / -328 to +1562 °F
Pt1000 (IEC 60751, $\alpha=0.00385$ )	-200 to +850 °C / -328 to +1562 °F
<b>Adjustments - Zero</b>	Any value within range limits
<b>Adjustments - Minimum span</b>	20 °C / 36 °F
<b>Output</b>	4-20 mA, temperature linear
<b>Sensor failure indication</b>	Upscale ( $\geq 21.0$ mA) or downscale ( $\leq 3.6$ mA)
<b>NAMUR Compliance</b>	Current limitations and failure currents acc. to NAMUR NE 43
<b>Response time</b>	0.4 to 26 s, adjustable filtering level
<b>Ambient temperature</b>	
Storage and operation	-40 to +85 °C / -40 to +185 °F
<b>Galvanic isolation</b>	None
<b>Power supply</b>	6 to 32 VDC
<b>Accuracy</b>	Max. of $\pm 0,15$ K or $\pm 0,15$ % of span
<b>Mounting</b>	DIN B-head or larger
<b>Vibration</b>	IEC 60068-2-6,10 g
<b>EMC</b>	EN 61326-1 and EN 61326-2-3
<b>Configuration</b>	App INOR Connect via NFC
<b>Terminal</b>	Single/stranded wires Max 1.5 mm <sup>2</sup> , Max 0.5 Nm torque
<b>Factory settings</b>	
Input	Pt100 3W, 0 to 100 °C
Output	4 to 20 mA
Sensor error indication	Upscale

### CONFIGURATION

**Before making a configuration of APAQ C130<sup>RTD</sup> you need to do following:**

1. Make sure that you have a mobile device with NFC communication activated
2. Download the app INOR Connect to your mobile device

#### Required versions:

##### iOS

iOS 13 or later and  
Iphone 7 or later for NFC

##### Android

Android 4.4 or later

#### Configuration procedure:

1. Launch the app by clicking on the App icon or holding your mobile device against the transmitter on the part of the device where NFC is located (only possible with Android).
2. Click on "Read Configuration" and hold your mobile device against the transmitter as explained in the first section.
3. In the app you can edit the following:
  - a. Sensor type and number of wires
  - b. Measuring range
  - c. Upscale or downscale  
Sensor error indication
  - d. Filter level
  - e. TAG-number
  - f. Password
4. Once you have set the desired values in the app, you transfer it to the transmitter by clicking the transfer button and holding the mobile device against the transmitter until a green check box appears confirming that the transfer has been completed.

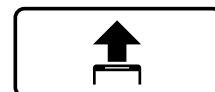
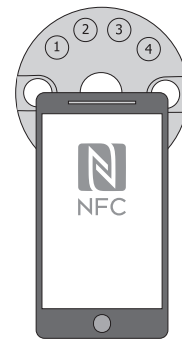

## OUTPUT LOAD DIAGRAM

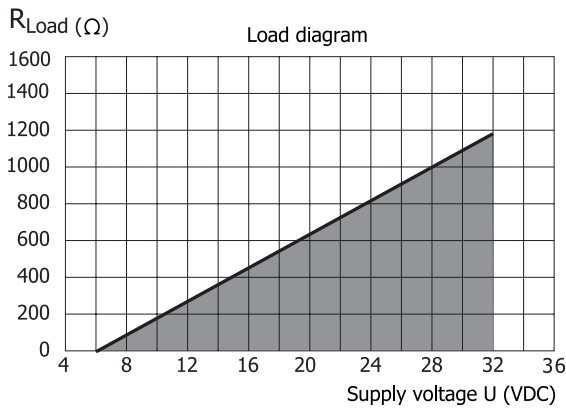

Maximum load depending on power supply

Formula for the max. permissible output load for APAQ C130<sup>RTD</sup>:

$$R_{Load} = (U-6)/0.022$$

## DIMENSIONS

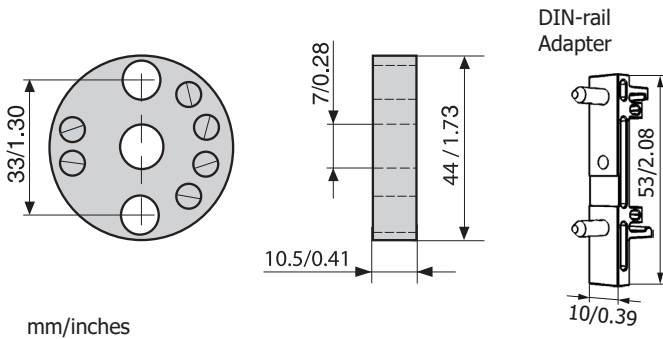

## LIMITED WARRANTY

INOR Process AB, or any other affiliated company within the Inor Group (hereinafter jointly referred to as "Inor"), hereby warrants that the Product will be free from defects in materials or workmanship for a period of five (5) years from the date of delivery ("Limited Warranty"). This Limited Warranty is limited to repair or replacement at Inor's option and is effective only for the first end-user of the Product. Upon receipt of a warranty claim, Inor shall respond within a reasonable time period as to its decision concerning:

- 1 Whether Inor acknowledges its responsibility for any asserted defect in materials or workmanship; and, if so,
- 2 the appropriate cause of action to be taken (i.e. whether a defective product should be replaced or repaired by Inor).

This Limited Warranty applies only if the Product:

- 1 is installed according to the instructions furnished by Inor;
- 2 is connected to a proper power supply;
- 3 is not misused or abused; and
- 4 there is no evidence of tampering, mishandling, neglect, accidental damage, modification or repair without the approval of Inor or damage done to the Product by anyone other than Inor.

This Limited Warranty is provided by Inor and contains the only express warranty provided.

**INOR SPECIFICALLY DISCLAIMS ANY EXPRESS WARRANTY NOT PROVIDED HEREIN AND ANY IMPLIED WARRANTY, GUARANTEE OR REPRESENTATION AS TO SUITABILITY FOR ANY PARTICULAR PURPOSE, PERFORMANCE, QUALITY AND ABSENCE OF ANY HIDDEN DEFECTS, AND ANY REMEDY FOR BREACH OF CONTRACT, WHICH BUT FOR THIS PROVISION, MIGHT ARISE BY IMPLICATION, OPERATION OF LAW, CUSTOM OF TRADE OR COURSE OF DEALING, INCLUDING IMPLIED WARRANTIES OF MERCHANTABILITY AND FITNESS FOR A PARTICULAR PURPOSE. EXCEPT AS PROVIDED HEREIN, INOR FURTHER DISCLAIMS ANY RESPONSIBILITY FOR LOSSES, EXPENSES, INCONVENIENCES, SPECIAL, DIRECT, SECONDARY OR CONSEQUENTIAL DAMAGES ARISING FROM OWNERSHIP OR USE OF THE PRODUCT.**

Products that are covered by the Limited Warranty will either be repaired or replaced at the option of Inor. Customer pays freight to Inor, and Inor will pay the return freight by post or other "normal" way of transport. If any other type of return freight

## INSTALLATION

APAQ C130<sup>RTD</sup> is designed to fit inside connection heads type DIN B or larger. The larger center hole, diameter 7 mm/0.28 inch, facilitates the pulling through of the sensor leads or an insert tube, greatly simplifying the mounting procedure.

**!** Connect input, output and power supply acc. to "CONNECTIONS". A convenient way to install the transmitter is to use the INOR mounting kits for in-head and DIN rail mounting.

**!** **CAUTION!** For the electrical connection to the in-head transmitter, the maximum torque for screw terminals is 0.5 Nm, for both tightening and untightening the screw.

## MOUNTING

How to mount on DIN-rail Adapter

Head mounting kit

Step 1

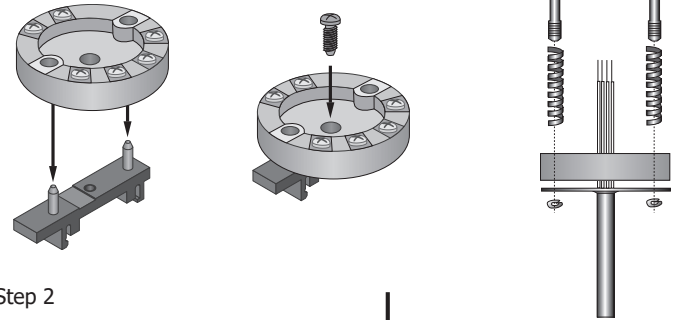

Step 2

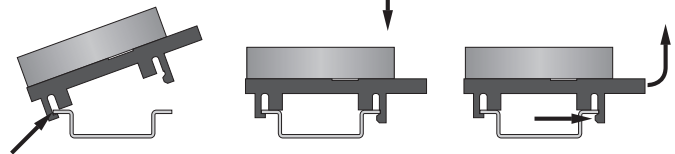

## CONNECTIONS

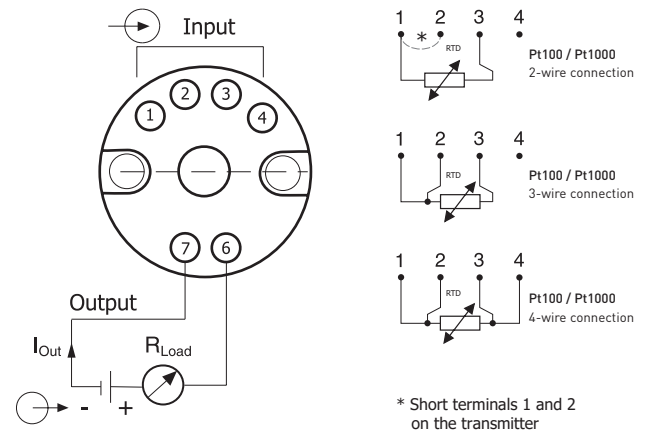

## ORDERING INFORMATION

APAQ C130 <sup>RTD</sup>	70C1300011
Head mounting kit	70ADA00017
DIN-rail Adapter + Screw (10 pcs)	70ADA00027

The transmitters are delivered with either a default factory setting or configured according to customer's specification.