



M2A Transmitter Operator's Manual

Part Number: 71-0305RK

Revision: R

Released: 3/10/21

WARNING

Read and understand this instruction manual before operating instrument. Improper use of the gas monitor could result in bodily harm or death.

Periodic calibration and maintenance of the gas monitor is essential for proper operation and correct readings. Please calibrate and maintain this instrument regularly! Frequency of calibration depends upon the type of use you have and the sensor types. Typical calibration frequencies for most applications are between 3 and 6 months, but can be required more often or less often based on your usage.

Product Warranty

RKI Instruments, Inc. warrants gas alarm equipment sold by us to be free from defects in materials, workmanship, and performance for a period of one year from date of shipment from RKI Instruments, Inc. Any parts found defective within that period will be repaired or replaced, at our option, free of charge. This warranty does not apply to those items which by their nature are subject to deterioration or consumption in normal service, and which must be cleaned, repaired, or replaced on a routine basis. Examples of such items are:

- a) Absorbent cartridges
- b) Pump diaphragms and valves
- c) Fuses
- d) Batteries
- e) Filter elements

Warranty is voided by abuse including mechanical damage, alteration, rough handling, or repair procedures not in accordance with the operator's manual. This warranty indicates the full extent of our liability, and we are not responsible for removal or replacement costs, local repair costs, transportation costs, or contingent expenses incurred without our prior approval.

THIS WARRANTY IS EXPRESSLY IN LIEU OF ANY AND ALL OTHER WARRANTIES AND REPRESENTATIONS, EXPRESSED OR IMPLIED, AND ALL OTHER OBLIGATIONS OR LIABILITIES ON THE PART OF RKI INSTRUMENTS, INC. INCLUDING BUT NOT LIMITED TO, THE WARRANTY OF MERCHANTABILITY OR FITNESS FOR A PARTICULAR PURPOSE. IN NO EVENT SHALL RKI INSTRUMENTS, INC. BE LIABLE FOR INDIRECT, INCIDENTAL, OR CONSEQUENTIAL LOSS OR DAMAGE OF ANY KIND CONNECTED WITH THE USE OF ITS PRODUCTS OR FAILURE OF ITS PRODUCTS TO FUNCTION OR OPERATE PROPERLY.

This warranty covers instruments and parts sold to users by authorized distributors, dealers, and representatives as appointed by RKI Instruments, Inc.

We do not assume indemnification for any accident or damage caused by the operation of this gas monitor, and our warranty is limited to the replacement of parts or our complete goods.

Table of Contents

| | |
|--|-----------|
| Chapter 1: Introduction | 6 |
| Overview | 6 |
| About the M2A Transmitter | 6 |
| About this Manual | 6 |
| Specifications | 7 |
| Chapter 2: Description | 10 |
| Overview | 10 |
| External Description | 10 |
| Internal Description | 18 |
| Chapter 3: Installation & Startup | 22 |
| Overview | 22 |
| Mounting the M2A Transmitter | 22 |
| Wiring the M2A Transmitter | 28 |
| Start Up | 35 |
| Chapter 4: Operation | 37 |
| Overview | 37 |
| Normal Operation | 37 |
| Information Screen | 37 |
| 4 - 20 mA Signal Output Operation | 37 |
| Alarm Indications | 38 |
| Chapter 5: Configuration Mode | 42 |
| Overview | 42 |
| Viewing & Changing M2A Parameters | 42 |
| Chapter 6: Gas Type Mode | 45 |
| Overview | 45 |
| Selecting the Gas Type | 45 |

| | |
|--|-----------|
| Chapter 7: Maintenance | 48 |
| Overview..... | 48 |
| Preventive Maintenance | 48 |
| Troubleshooting | 48 |
| Calibration Frequency..... | 50 |
| Calibration, Combustible Gas, CO ₂ , and Toxic Versions | 50 |
| Calibration, Oxygen Version | 54 |
| Replacing Components of the M2A | 56 |
| Chapter 8: RS-485 Modbus Output | 61 |
| Overview..... | 61 |
| Wiring the M2A in a Modbus System | 61 |
| Using the M2A in a 4-wire Modbus System..... | 64 |
| Modbus Mode..... | 64 |
| Supported Modbus Functions..... | 66 |
| Chapter 9: Parts List | 71 |
| Appendix A: Control Button Quick Reference Guide..... | 76 |
| Appendix B: PLC and DCS Device Wiring | 77 |
| Appendix C: Function Code 16 Registers..... | 79 |

Chapter 1: Introduction

Overview

This chapter briefly describes the M2A Transmitter. This chapter also describes the *M2A Transmitter Operator's Manual* (this document). Table 1 at the end of this chapter lists the specifications for the M2A.

About the M2A Transmitter

The M2A transmitter is a fixed mount, continuous-monitoring detector head. All user adjustable parameters may be accessed using push button switches. In addition, calibration may be performed non-intrusively by use of a magnetic wand accessory which activates magnetic switches through a window at the front face of the detector head.

The M2A displays the current gas reading on an OLED display which is visible through the window in the cover (front face) and provides a 4 - 20 mA signal which indicates the target gas reading for use by a gas monitoring controller, recording device, or programmable controller. The M2A also provides an RS-485 Modbus output. Three sets of relay contacts, two controlled by the gas alarms and one by the fail alarm, rated at 115 VAC 5 amps are available for controlling devices such as lights or horns or for controlling higher rated relays.

Four operating modes allow you to display and change setup and calibration settings and change the gas type. They are Calibration Mode, Configuration Mode, Gas Type Mode, and Modbus Mode.

About this Manual

The *M2A Transmitter Operator's Manual* uses the following conventions for notes, cautions, and warnings.

NOTE: Describes additional or critical information.

CAUTION: Describes potential damage to equipment.

WARNING: Describes potential danger that can result in injury or death.

Specifications

Table 1 lists specifications for the M2A.

Table 1: M2A Specifications

| | |
|---|---|
| <p>Target Gas/ Detection Range</p> | <p><u>Combustible Gas/Carbon Dioxide (CO₂)</u></p> <ul style="list-style-type: none"> • Catalytic LEL: 0 - 100% LEL, 1% LEL increments (CH₄ calibration unless otherwise specified. H₂ specific detector available) • Catalytic CH₄ ppm: 0 - 9000 ppm, 20 ppm increments • IR (infrared) CH₄ LEL: 0 - 100% LEL, 1% LEL increments • IR HC LEL: 0 - 100% LEL, 1% LEL increments (propane calibration) • IR CH₄ Volume: 0 - 5.00% volume, 0.01% increments • IR CH₄ Volume: 0 - 100 % volume, 1% increments • IR CO₂ ppm: 0 - 5,000 ppm, 20 ppm increments • IR CO₂ ppm: 0 - 10,000 ppm, 20 ppm increments • IR CO₂ Volume: 0 - 5.00 % volume, 0.01% increments • IR CO₂ Volume: 0 - 50.0 % volume, 0.1% increments • IR CO₂ Volume: 0 - 100 % volume, 1% increments <p><u>Oxygen</u></p> <ul style="list-style-type: none"> • Oxygen (O₂): 0 - 25.0 % volume, 0.1% increments <p><u>CO/H₂S</u></p> <ul style="list-style-type: none"> • Carbon Monoxide (CO): 0 - 300 ppm, 1 ppm increments • Carbon Monoxide (CO): 0 - 200 ppm, 1 ppm increments • Carbon Monoxide (CO): 0 - 100 ppm, 1 ppm increments • Hydrogen Sulfide (H₂S): 0 - 100 ppm, 1 ppm increments • Hydrogen Sulfide (H₂S): 0 - 50 ppm, 0.1 ppm increments <p><u>Toxic</u></p> <ul style="list-style-type: none"> • Ammonia (NH₃): 0 - 75.0 ppm, 0.1 ppm increments • Ammonia (NH₃): 0 - 100 ppm, 1 ppm increments • Ammonia (NH₃): 0 - 200 ppm, 1 ppm increments • Ammonia (NH₃): 0 - 500 ppm, 1 ppm increments • Arsine (AsH₃): 0 - 1.50 ppm, 0.01 ppm increments • Chlorine (Cl₂): 0 - 3.00 ppm, 0.01 ppm increments • Chlorine (Cl₂): 0 - 5.00 ppm, 0.01 ppm increments • Chlorine (Cl₂): 0 - 10.0 ppm, 0.1 ppm increments • Chlorine Dioxide (ClO₂): 0 - 1.00 ppm, 0.01 ppm increments • Chlorine Dioxide (ClO₂): 0 - 3.00 ppm, 0.01 ppm increments • Chlorine Dioxide (ClO₂): 0 - 5.00 ppm, 0.01 ppm increments • Hydrogen Cyanide (HCN): 0 - 15.0 ppm, 0.1 ppm increments • Phosphine (PH₃): 0 - 1.00 ppm, 0.01 ppm increments • Sulphur Dioxide (SO₂): 0 - 6.00 ppm, 0.01 ppm increments |
| <p>Alarm Settings (Alarm 1/Alarm 2)*</p> | <p>Ammonia (0 - 75.0 ppm and 0 - 100 ppm): 12 ppm / 25 ppm Ammonia (0 - 200 ppm): 25 ppm / 35 ppm Ammonia (0 - 500 ppm): 35 ppm / 300 ppm Arsine: 0.20 ppm / 0.50ppm Carbon Dioxide (0 - 5,000 ppm): 2,500 ppm / 5,000 ppm Carbon Dioxide (0 - 9,000 ppm): 2,000 ppm / 5,000 ppm Carbon Dioxide (0 - 5.00%): 0.50 % / 3.00 % Carbon Dioxide (0 - 50.0%): 50.0% / 50.0% Carbon Dioxide (0 - 100%): 100% / 100%</p> |

Table 1: M2A Specifications

| | | | |
|--|--|------------------------|----------------------------|
| Alarm Settings (Alarm 1/Alarm 2)*, cont'd | Carbon Monoxide (all ranges): 25 ppm / 50 ppm Chlorine (0 - 3.00 ppm): 0.50 ppm / 1.00 ppm Chlorine (0 - 5.00 ppm): 0.50 ppm / 1.50 ppm Chlorine (0 - 10.0 ppm): 1.0 ppm / 3.0 ppm Chlorine Dioxide (0 - 1.00 ppm): 0.10 ppm / 0.30 ppm Chlorine Dioxide (0 - 3.00 ppm): 0.30 ppm / 1.00 ppm Chlorine Dioxide (0 - 5.00 ppm): 0.50 ppm / 1.00 ppm Combustible Gas (%LEL): 10 %LEL / 50 %LEL Combustible Gas (0-100%Volume): 100 % / 100 % Hydrogen Cyanide: 5.0 ppm / 10.0 ppm Hydrogen Sulfide (0 - 50 ppm): 5.0 ppm / 10.0 ppm Hydrogen Sulfide (0 - 100 ppm): 10 ppm / 50 ppm Methane (ppm): 5000 ppm / 8000 ppm Methane (0-5.00%Volume): 0.5% / 2.5 % Oxygen: 19.5% (decreasing) / 23.5% (increasing) Phosphine: 0.10 ppm / 0.30 ppm Sulphur Dioxide: 1.00 ppm / 2.00 ppm | | |
| Construction (housing) | Explosion-proof Junction Box, NEMA 4X | | |
| Area Classification | Explosion-proof for Class I, Groups B, C, and D (Combustible, CO ₂ , CSA Type CO and H ₂ S, and CSA Type oxygen) | | |
| Sampling Method | Diffusion | | |
| Input Power | 10 - 30 VDC | | |
| Controls | <ul style="list-style-type: none"> • Three push button switches • Three magnetic switches for non-intrusive calibration | | |
| Weight | 4.5 lbs. | | |
| Signal Output | <ul style="list-style-type: none"> • 4 to 20 mA with impedance maximums listed below <ul style="list-style-type: none"> -12 VDC input: 500 ohms impedance max -24 VDC input: 1000 ohms impedance max • RS-485 Modbus | | |
| | | Explosion Proof | Non-Explosion Proof |
| Operating Temperature | Catalytic LEL/ppm | -40°C to 75°C | N/A |
| | Oxygen | -20°C to 45°C | -20°C to 50°C |
| | H₂S | -40°C to 40°C | -40°C to 50°C |
| | CO | -5°C to 40°C | -20°C to 50°C |
| | Toxic (ESM-01) | N/A | -10°C to 40°C |
| | Toxic (CT-7 Series) | N/A | -20°C to 40°C |
| | Infrared Combustible | -20°C to 50°C | -40°C to 50°C |
| | Infrared CO₂ | -20°C to 50°C | -40°C to 50°C |

Table 1: M2A Specifications

| | |
|--|---|
| <p>Accuracy</p> | <p><u>Catalytic Combustible Gas (LEL range):</u> $\pm 5\%$ of reading or $\pm 2\%$ LEL (whichever is greater) <u>Catalytic CH₄ (ppm range):</u> $\pm 5\%$ of reading or ± 50 ppm (whichever is greater)** <u>IR Combustible Gas/IR CO₂:</u> $\pm 5\%$ of reading or $\pm 2\%$ of full scale (whichever is greater) <u>Oxygen:</u> $\pm 0.5\%$ O₂ <u>Hydrogen Sulfide:</u> $\pm 5\%$ of reading or ± 2 ppm H₂S (whichever is greater) <u>Carbon Monoxide:</u> $\pm 5\%$ of reading or ± 5 ppm CO (whichever is greater) <u>Toxic Sensors (ESM-01 Type and CT-7 Series Type):</u> $\pm 10\%$ of reading or $\pm 5\%$ of full scale (whichever is greater)</p> |
| <p>* These are RKI factory settings. See “Viewing & Changing M2A Parameters” on page 42 to change the alarm settings. ** Independent of zero drift.</p> | |

WARNING: *When using the M2A, you must follow the instructions and warnings in this manual to assure proper and safe operation of the M2A and to minimize the risk of personal injury. Be sure to maintain and periodically calibrate the M2A as described in this manual.*

Chapter 2: Description

Overview

This chapter describes external and internal components of the M2A Transmitter.

External Description

This section describes the junction box and all external components of the M2A transmitter.

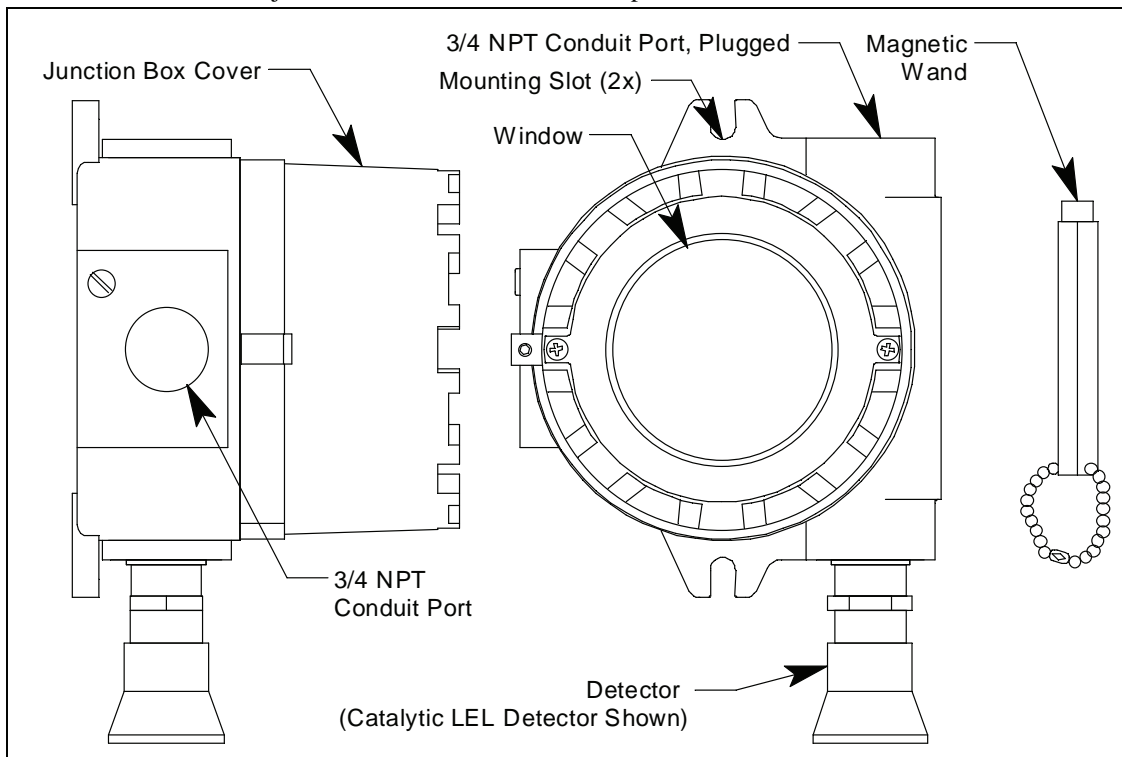

Figure 1: M2A External Components

Junction Box

The M2A's cast aluminum junction box is dust and weather resistant. The junction box also protects the M2A and all connections made to it. Use the three 3/4 NPT conduit ports to mount the detector to the junction box (factory installed in the bottom port) and connect wiring from an external device (left port). The top port is shipped with a factory installed and sealed conduit plug to avoid leaks into the junction box. If necessary, the conduit plug can be removed and the top port can be used for wiring.

WARNING: *If the top conduit port is used for wiring, be sure to seal the threads to ensure water does not enter the junction box. See "Wiring the M2A Transmitter" on page 28 for complete wiring instructions.*

Use the junction box's two mounting holes to mount the M2A to a vertical surface at the monitoring site. The window in the cover on the front of the junction box allows you to view the OLED display and use the magnetic wand to actuate the magnetic control switches so you can perform non-intrusive calibration. Removing the cover

allows you to access the interior of the junction box.

Magnetic Wand

The magnetic wand is a short plastic rod with a magnet in one end. It is used to actuate the magnetic control switches on the control PCB while the junction box cover is still installed so that non-intrusive calibration can be performed.

Gas Detector

The gas detector senses the target gas and is mounted in a 3/4 NPT conduit port on the right bottom side of the M2A. A variety of detectors may be used with the M2A. See the sections below for descriptions of each type of detector.

Catalytic Detectors

The catalytic detectors have a 1/2 NPT thread and require a 3/4 NPT x 1/2 NPT reducer to install in the detector port.

The table below outlines the M2A part numbers and replacement detector part numbers for the catalytic detectors.

Table 2: Catalytic Detectors

| Target Gas, Range | M2A Part Number | Detector Used |
|-------------------------------|-----------------|---|
| Combustible Gas, 0 - 100% LEL | 65-2640RK | 61-0140RK (Catalytic UL version) |
| | 65-2640RK-05 | 61-0140RK-05 (Catalytic CSA version) |
| Hydrogen, 0 - 100% LEL | 65-2641RK | NC-6205-01 (Catalytic UL version, hydrogen specific) |
| | 65-2641RK-05 | NC-6205-05 (Catalytic CSA version, hydrogen specific) |
| Methane, 0 - 9000 ppm | 65-2647RK | 61-0140RKA (Catalytic UL version) |
| | 65-2647RK-05 | 61-0140RKA-05 (Catalytic CSA version) |

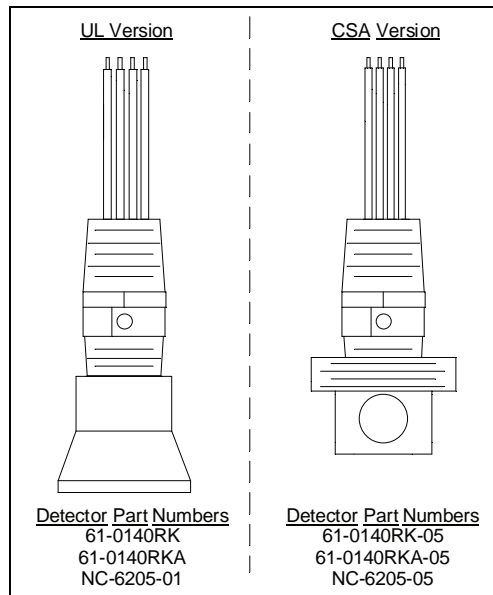

Figure 2: Catalytic Sensors

Infrared (IR) Detectors

The IR combustible detectors are generally used instead of the catalytic combustible detectors in applications where there may be catalyst poisons such as silicone present or where oxygen is not present in the monitoring environment.

The table below outlines the M2A part numbers and replacement detector part numbers for the infrared (IR) detectors.

Table 3: Infrared (IR) Detectors

| Target Gas, Range | M2A Part Number | Detector Used |
|------------------------------------|------------------------|----------------------|
| CH ₄ , 0 - 100% LEL | 65-2649RK-CH4 | 61-0190RK-CH4 (UL) |
| | 65-2664RK-CH4 | 61-0197RK-CH4 |
| CH ₄ , 0 - 5.00% volume | 65-2649RK-CH4-5 | 61-0190RK-CH4 (UL) |
| CH ₄ , 0 - 100% volume | 65-2658RK-CH4 | 61-0192RK-CH4 (UL) |
| | 65-2665RK-CH4 | 61-0199RK-CH4 |
| CO ₂ , 0 - 5,000 ppm | 65-2660RK-02 | 61-0191RK-02 (UL) |
| | 65-2661RK-02 | 61-0198RK-02 |
| CO ₂ , 0 - 9,000 ppm | 65-2660RK-01 | 61-0191RK-01 (UL) |
| | 65-2661RK-01 | 61-0198RK-01 |
| CO ₂ , 0 - 5% volume | 65-2660RK-03 | 61-0191RK-03 (UL) |
| | 65-2661RK-03 | 61-0198RK-03 |
| CO ₂ , 0 - 50% volume | 65-2660RK-05 | 61-0191RK-05 (UL) |
| | 65-2661RK-05 | 61-0198RK-05 |
| CO ₂ , 0 - 100% volume | 65-2660RK-10 | 61-0191RK-10 (UL) |
| | 65-2661RK-10 | 61-0198RK-10 |
| HC, 0 - 100% LEL (cal. to propane) | 65-2649RK-HC | 61-0190RK-HC (UL) |
| | 65-2664RK-HC | 61-0197RK-HC |

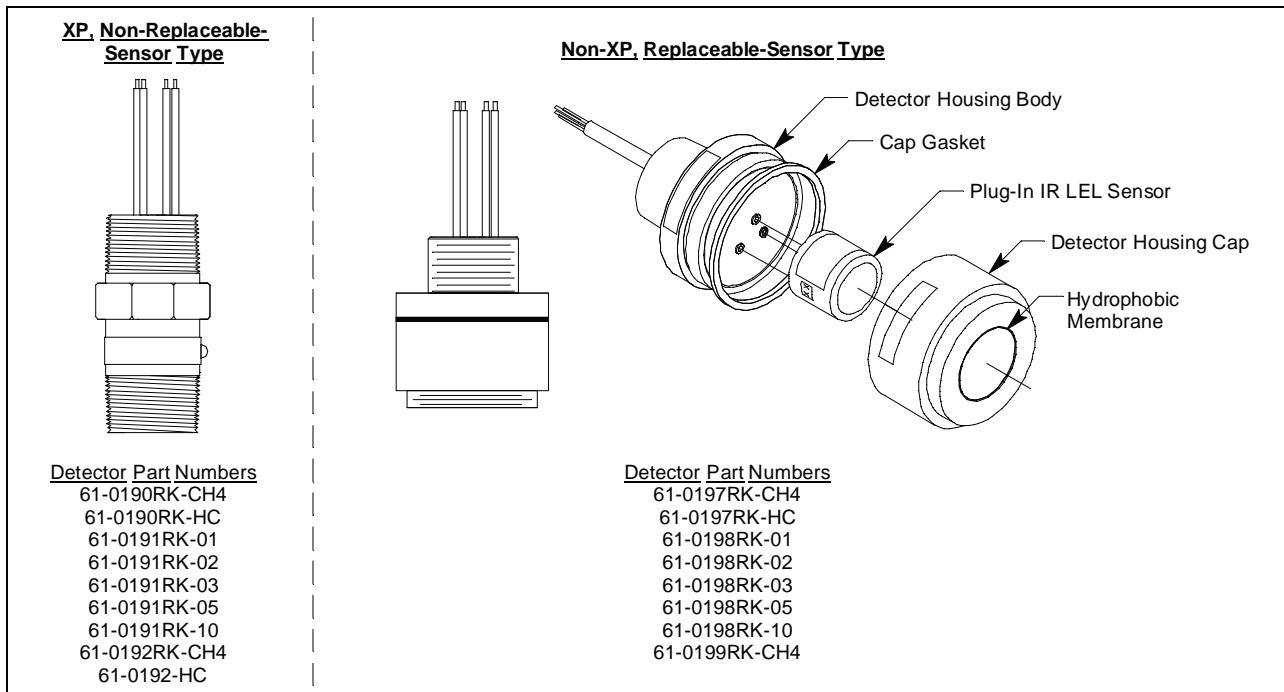

Figure 3: Infrared (IR) Sensors

Oxygen Detectors

There are three types of oxygen detectors available: a non-explosion proof partial pressure type, a non-explosion proof capillary type with a replaceable sensor, and an explosion proof (CSA) capillary type with a replaceable sensor. The capillary type's output is less susceptible to variations in atmospheric pressure than the partial pressure type. The CSA type oxygen detector (65-2514RK) and the non-explosion proof capillary type detector (65-2494RK) has a replaceable plug-in sensor inside the detector housing. The entire oxygen detector must be removed if replacement is required for the 65-2510RK.

The table below outlines the M2A part numbers and replacement detector part numbers for the oxygen detectors.

Table 4: Oxygen Detectors

| Target Gas, Range | M2A Part Number | Detector Used |
|-------------------|-----------------|------------------------------|
| Oxygen, 0 - 25% | 65-2643RK-05 | 65-2514RK (capillary, CSA) |
| | 65-2644RK | 65-2510RK (partial pressure) |
| | 65-2666RK | 65-2494RK (capillary) |

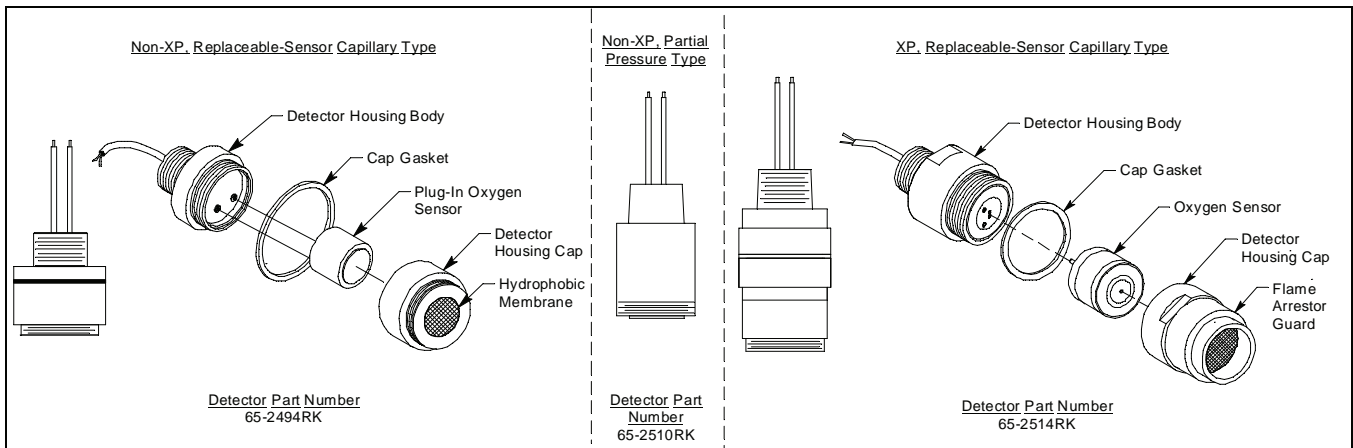

Figure 4: Oxygen Detectors

CO and H₂S Detectors

Both types of CO and H₂S detectors (explosion-proof and non-explosion-proof) have replaceable plug-in sensors inside the detector housing.

The CO detectors include a charcoal filter disk which is held onto the sensor with a rubber retaining boot. The charcoal filter disk scrubs out interfering gases to which the CO sensor responds such as H₂S and certain hydrocarbons.

The 65-2428 and 65-2428-01 explosion-proof H₂S detectors both include a rubber boot and a spacer which help ensure that the sensor remains plugged into the detector housing body. The only difference between the 65-2428 and the 65-2428-01 is that the sensor used in the 65-2428-01 is resistant to degradation caused by frequent exposure to low levels of H₂S or occasional exposure to high levels of H₂S.

The 65-2495RK non-explosion-proof H₂S detector includes an adhesive-backed gasket inside the detector housing cap which helps ensure that the sensor remains plugged into the detector housing body.

The table below outlines the M2A part numbers and replacement detector part numbers for the CO and H₂S detectors.

Table 5: CO and H₂S Detectors

| Target Gas, Range | M2A Part Number | Detector Used |
|-------------------------------|-----------------|------------------|
| CO, 0 - 300 ppm | 65-2646RK-05 | 65-2438 (CSA) |
| | 65-2663RK | 65-2496RK |
| CO, 0 - 200 ppm | 65-2646RK-05-02 | 65-2438-01 |
| CO, 0 - 100 ppm | 65-2646RK-05-01 | 65-2438-01 |
| H ₂ S, 0 - 100 ppm | 65-2645RK-05 | 65-2428 (CSA) |
| | 65-2645-05-07 | 65-2428-01 (CSA) |
| | 65-2662RK | 65-2495RK |

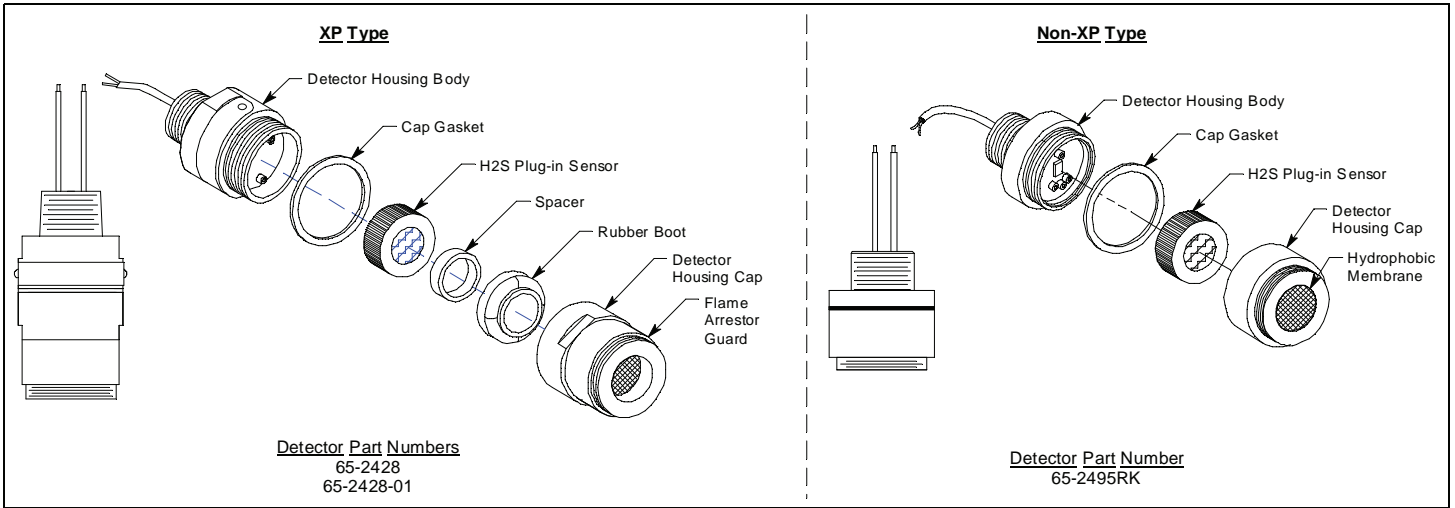

Figure 5: H₂S Detectors

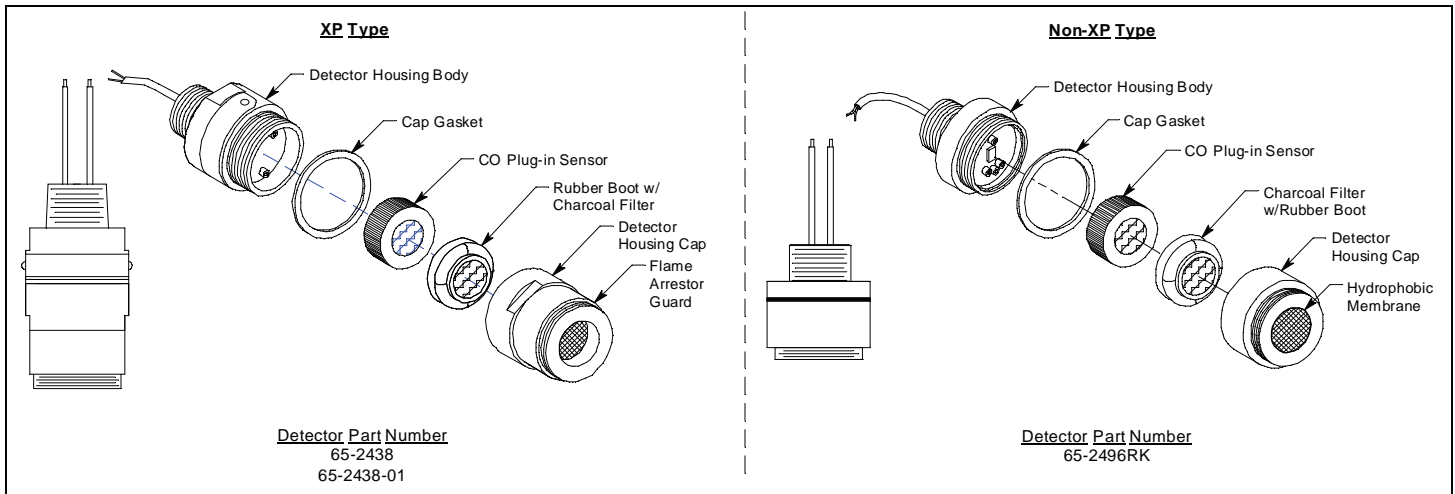

Figure 6: CO Detectors

ESM-01 Detectors

The construction of the various ESM-01 detectors is similar. Each of the ESM-01 detectors has a different replaceable plug-in sensor that protrudes through the detector housing cap. Although ESM-01 detectors look the same except for the plug-in detector, the detector housing which includes the detector socket and conditioning circuitry is specific to a sensor type. For example, a detector housing from a Cl₂ detector cannot be used with an NH₃ detector. One of the two detector wires is color coded for each specific detector type. The ESM-01 detectors include a removable splashguard that screws onto the detector housing cap. When it is necessary to apply gas to an ESM-01 detector, remove the splashguard to allow access to the sensor that protrudes through the detector housing cap. You can then push the appropriate ESM-01 calibration cup onto the sensor.

The table below outlines the M2A part numbers and replacement detector part numbers for the ESM-01 detectors.

Table 6: ESM-01 Detectors

| Target Gas, Range | M2A Part Number | Detector Used |
|--------------------------------|-----------------|-----------------|
| AsH ₃ , 0 - 1.5 ppm | 65-2648RK-ASH3 | 65-2300RK-ASH3 |
| Cl ₂ , 0 - 3 ppm | 65-2648RK-CL2 | 65-2300RK-CL2 |
| Cl ₂ , 0 - 10 ppm | 65-2648RK-CL-10 | 65-2300RK-CL-10 |
| HCN, 0 - 15 ppm | 65-2648RK-HCN | 65-2300RK-HCN |
| NH ₃ , 0 - 75 ppm | 65-2648RK-NH3 | 65-2300RK-NH3 |
| PH ₃ , 0 - 1 ppm | 65-2648RK-PH3 | 65-2300RK-PH3 |
| SO ₂ , 0 - 6 ppm | 65-2648RK-SO2 | 65-2300RK-SO2 |

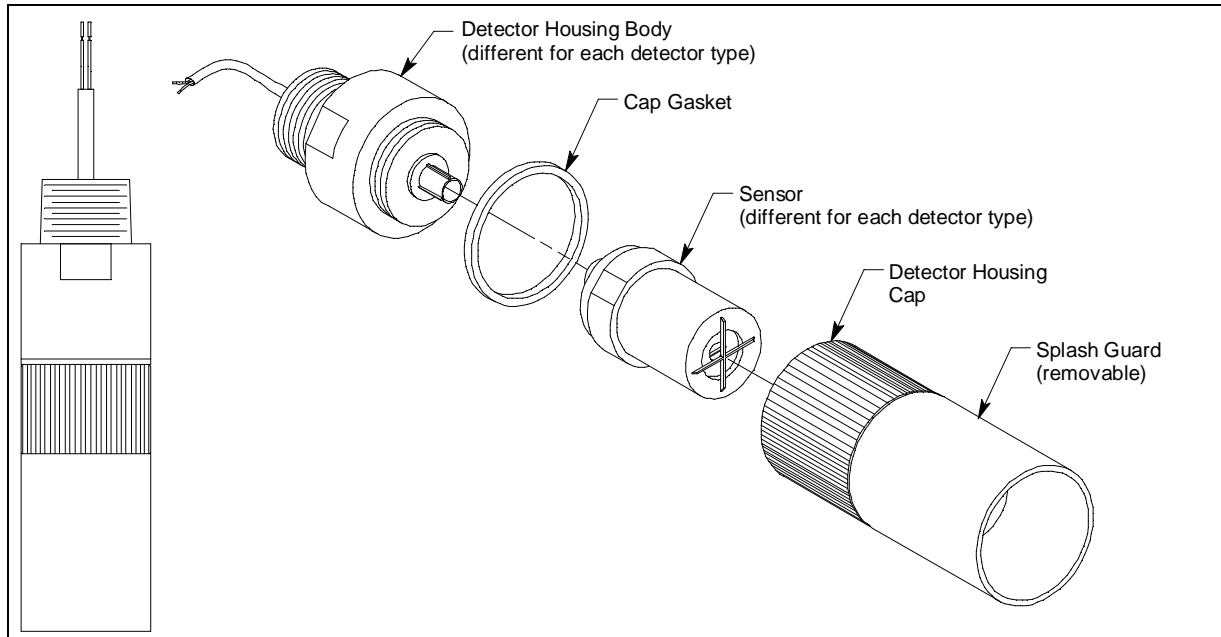

Figure 7: ESM-01 Type Detector

CT-7 Series Detectors

The CT-7 Series detectors for Cl₂ and ClO₂ have a replaceable plug-in sensor inside the detector housing. An adhesive backed gasket inside the detector housing cap helps ensure that the sensor remains plugged into the detector housing body.

The table below outlines the M2A part numbers and replacement detector part numbers for the CT-7 Series detectors.

Table 7: CT-7 Series Detectors

| Target Gas, Range | M2A Part Number | Detector Used |
|--------------------------------|-----------------|----------------|
| Cl ₂ , 0 - 3 ppm | 65-2670-CL2-3 | 65-2302-CL2-3 |
| Cl ₂ , 0 - 5 ppm | 65-2670-CL2-5 | 65-2302-CL2-5 |
| Cl ₂ , 0 - 10 ppm | 65-2670-CL2-10 | 65-2302-CL2-10 |
| ClO ₂ , 0 - 1 ppm | 65-2670-CLO2-1 | 65-2302-CLO2-1 |
| ClO ₂ , 0 - 3 ppm | 65-2670-CLO2-3 | 65-2302-CLO2-3 |
| ClO ₂ , 0 - 5 ppm | 65-2670-CLO2-5 | 65-2302-CLO2-5 |
| HCN, 0 - 15.0 ppm | 65-2670-HCN-15 | 65-2302-HCN-15 |
| NH ₃ , 0 - 75.0 ppm | 65-2670-NH3-75 | 65-2302-NH3-75 |
| NH ₃ , 0 - 100 ppm | 65-2670-NH3-1 | 65-2302-NH3-1 |
| NH ₃ , 0 - 200 ppm | 65-2670-NH3-2 | 65-2302-NH3-2 |
| NH ₃ , 0 - 500 ppm | 65-2670-NH3-5 | 65-2302-NH3-5 |

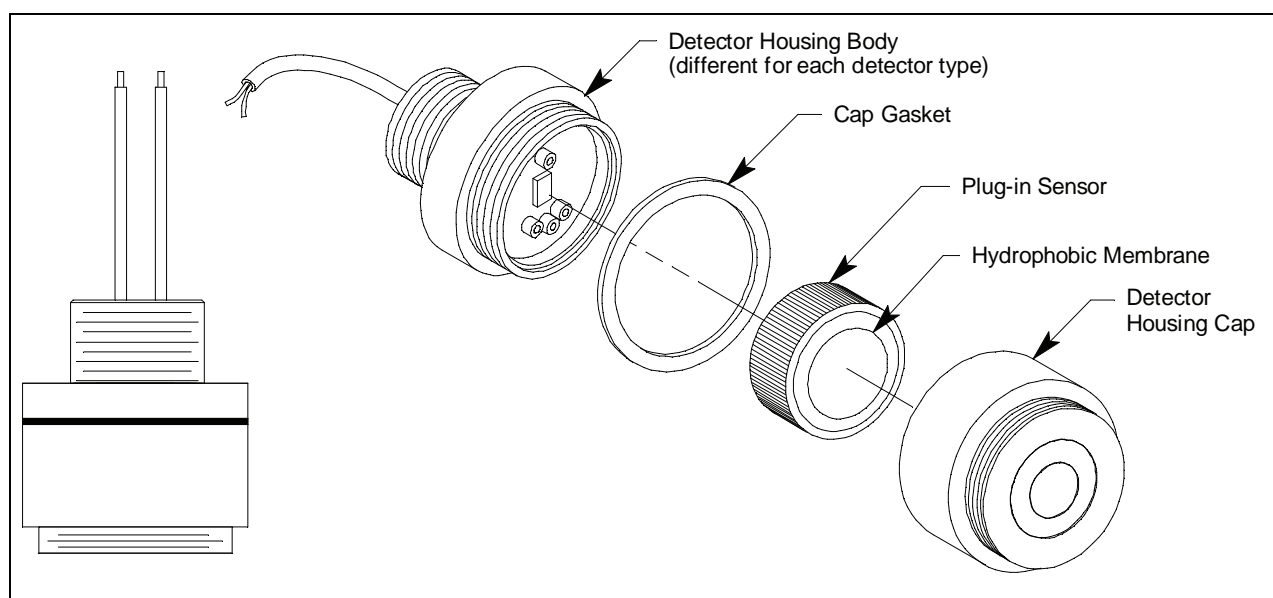

Figure 8: CT-7 Series Detectors

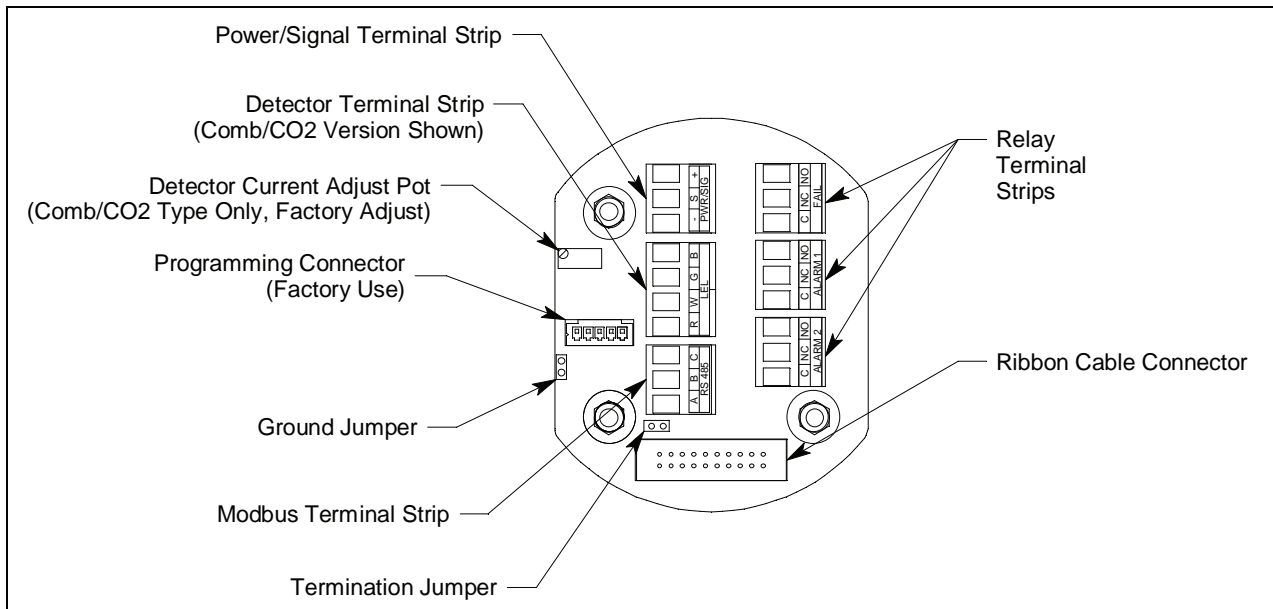

Figure 10: Terminal PCB Component Location

Power/Signal Terminal Strip

The power/signal terminal strip is a three position plug-in style terminal strip located at the top of the left terminal column. It is used to connect 24 VDC power to the M2A and to connect the 4 - 20 mA output signal to a device.

The signal output, the S terminal, does not have to be connected for the M2A to function. The S terminal is used if you want to connect the 4 - 20 mA output signal to another device such as a gas monitoring controller, chart recorder, or programmable controller (PLC).

Detector Terminal Strip

The detector terminal strip is a four position plug-in style terminal strip and is the middle terminal strip in the left terminal column. For a combustible or CO₂ M2A, all four terminals are used to connect the detector to the M2A. For a toxic or oxygen M2A, only two of the terminals are used for connecting a detector; two terminals are dedicated for connecting a toxic detector and two are dedicated for connecting an oxygen detector (only one detector can be installed).

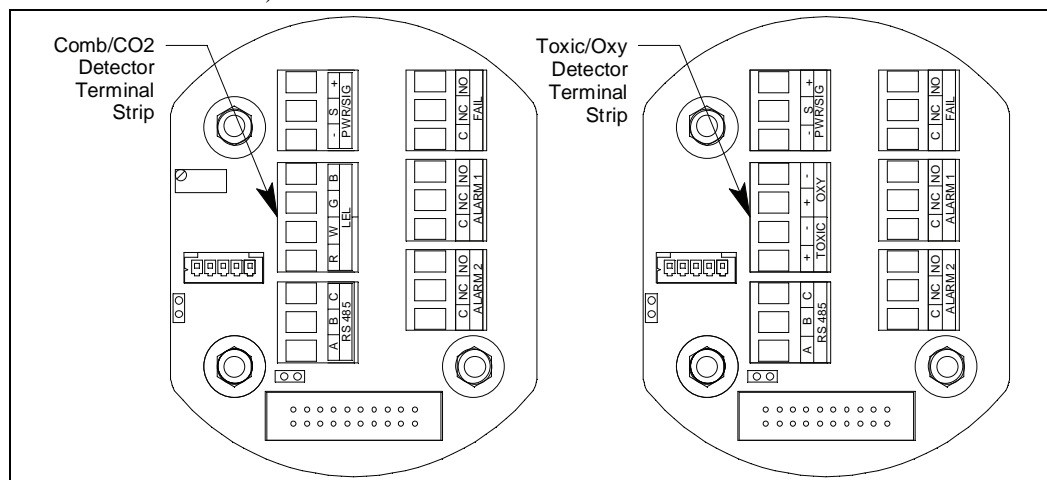

Figure 11: Detector Terminal Strip

NOTE: The detector is factory-wired to the M2A. See “Wiring the M2A Transmitter” on page 28 for all wiring procedures related to M2A.

Modbus Terminal Strip

The Modbus terminal strip is a three position plug-in style terminal strip and is the bottom terminal strip in the left terminal column. It allows connection of the M2A into a Modbus network.

Relay Terminal Strips

The right column of terminal strips consists of, from top to bottom, the fail, alarm 1, and alarm 2 relay terminal strips. They are three-position plug-in style terminal strips. The relay terminal strips are used to connect devices such as lights and horns that are controlled by the relay contacts. The relay contacts are rated at 115 VAC, 5 amps. The relay contacts may also be used to control higher rated relays.

Termination Jumper

A two pin header with a termination jumper installed is located below the Modbus terminal strip. Leave this jumper installed unless directed to remove it for a Modbus installation. See “Chapter 8: RS-485 Modbus Output” on page 61 for a description of using the M2A in a Modbus system.

Ground Jumper

A two pin header with a jumper installed is located along the left side of the terminal PCB. Leave this jumper installed unless directed to remove it for a Modbus installation. See “Chapter 8: RS-485 Modbus Output” on page 61 for a description of using the M2A in a Modbus system.

Control PCB

The OLED display and control switches are located on the control PCB. It is installed on top of the terminal PCB by lining up its three spacing standoffs with the banana jacks in the terminal PCB mounting standoffs and pushing it onto the banana jacks. The jacks retain the control PCB.

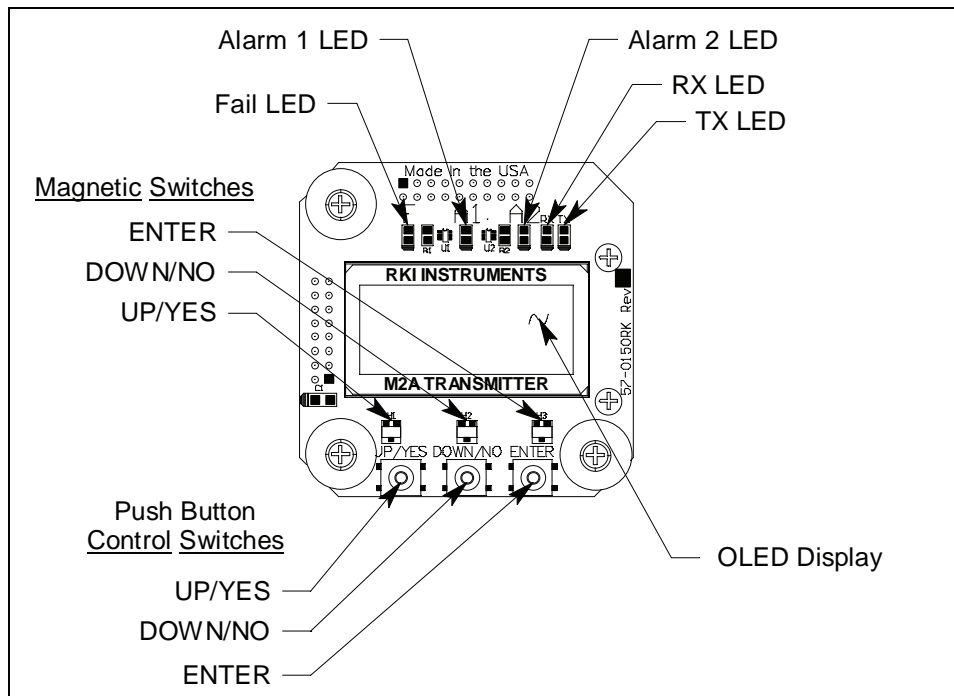

Figure 12: Control PCB Component Location

OLED Display

The OLED display is located at the top of the control PCB. It indicates the current gas reading and displays messages and parameters in the M2A's programs.

Control Buttons

The M2A includes three push button switches that allow you to enter the M2A's operating modes, navigate through the modes, update settings, and save changes to the settings. The push button switches are located along the bottom edge of the control PCB (see Figure 12). The UP/YES button is on the left, the DOWN/NO button is in the middle, and the ENTER button is on the right.

Table 8: M2A Control Button Functions

| Switch | Function |
|---------------|--|
| UP (YES) | <ul style="list-style-type: none">• Saves settings• Changes the displayed setting• Enters the Calibration Program• Enters Gas Type Mode (press with DOWN/NO button)• Enters Configuration Mode (press with ENTER button) |
| DOWN (NO) | <ul style="list-style-type: none">• Cancels setting changes• Changes the displayed setting• Enters Gas Type Mode (press with UP/YES button)• Enters Modbus Mode (press with ENTER button)• Displays the Information Screen |
| ENTER | <ul style="list-style-type: none">• Initiates operations• Enters Configuration Mode (press with UP/YES button)• Enters Modbus Mode (press with DOWN/NO button)• Functions as an alarm reset switch |

Just above each push button switch is a magnetic switch with the same function as the push button switch below it. The magnetic switches are for use in non-intrusive calibration. They are actuated by bringing the magnetic wand close enough to them to actuate them. Although the magnetic switches have the same functions as the push button switches, it is not practical to use them for operations other than calibration because it is not possible to actuate two magnetic switches at once with only one magnetic wand. Since displaying the Information Screen only requires the use of one switch, the wand may be used to show the Information Screen (see "Information Screen" on page 37).

Status LEDs

The M2A includes five status LEDs that are located above the display (see Figure 12).

- **Fail LED**
The fail LED turns on when the M2A is experiencing a fail condition. A fail condition can be caused by a detector failure or low detector signal.
- **Alarm 1 LED**
The alarm 1 LED is on when the M2A is experiencing an alarm 1 condition.
- **Alarm 2 LED**
The alarm 2 LED is on when the M2A is experiencing an alarm 2 condition.
- **RX & TX LED's**
These LED's indicate data being received (RX) and transmitted (TX) when the M2A's Modbus output is operating.

Chapter 3: Installation & Startup

Overview

This chapter describes procedures to mount the M2A Transmitter in the monitoring environment and wire it to input power and devices.

Mounting the M2A Transmitter

1. Select a mounting site that is representative of the monitoring environment. Consider the following when you select the mounting site.
 - Select a site where the M2A is not likely to be bumped or disturbed. Make sure there is sufficient room to perform start-up, maintenance, and calibration procedures.
 - Select a site where the target gas is likely to be found first. For lighter gases, mount the detector near the ceiling; for heavier gases, mount the detector near the floor.
2. At the monitoring site, use #10 screws through the junction box's two mounting holes to secure the junction box to a vertical surface. Figure 13 - Figure 20 show the outline and mounting dimensions for each version of the M2A. Mount the M2A with the detector facing down as shown in the following figures.

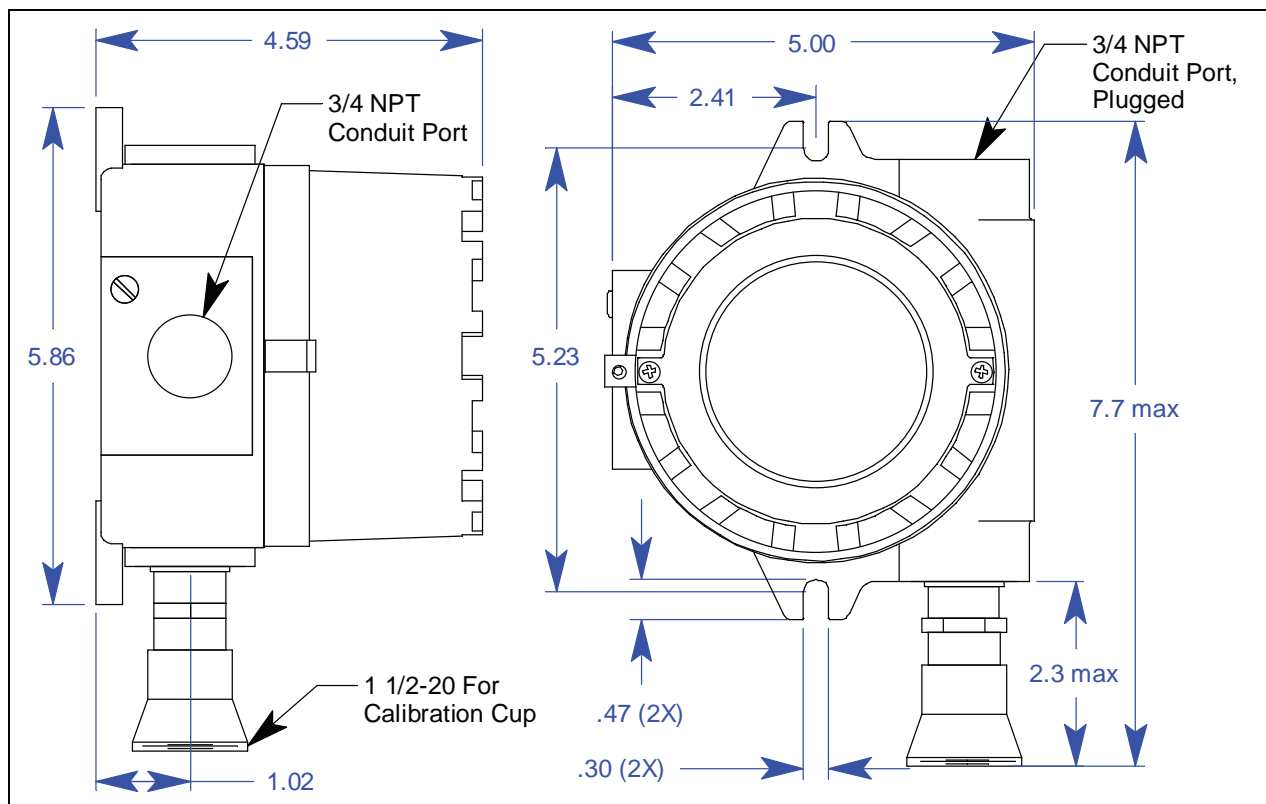

Figure 13: Outline & Mounting Dimensions, Catalytic LEL and ppm, UL Version

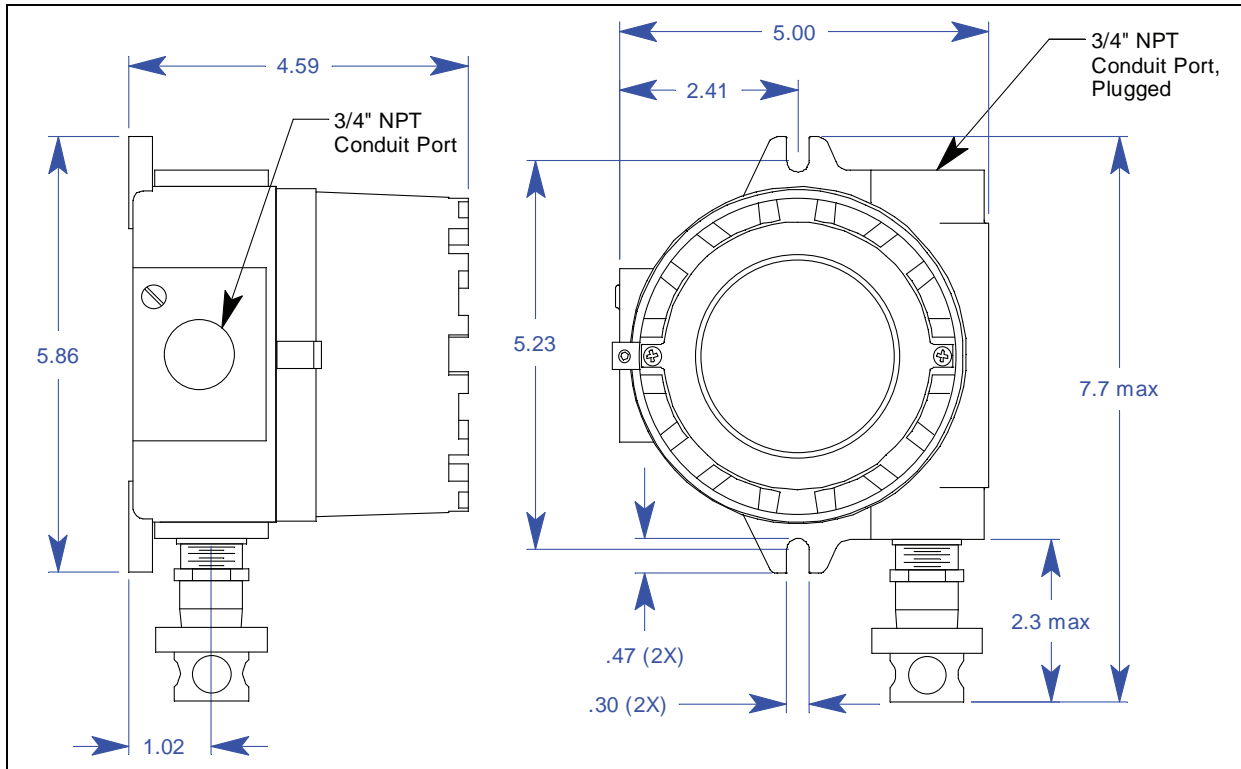

Figure 14: Outline & Mounting Dimensions, Catalytic LEL and ppm, CSA Version

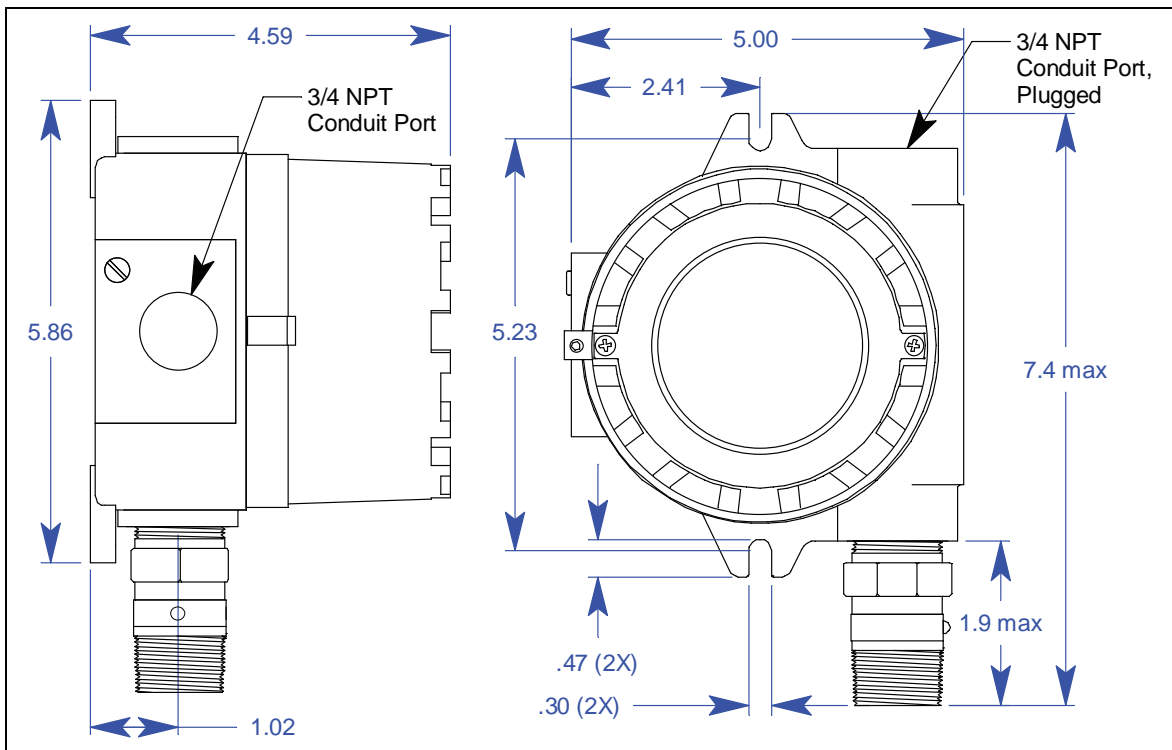

Figure 15: Outline & Mounting Dimensions, IR Combustible & CO₂

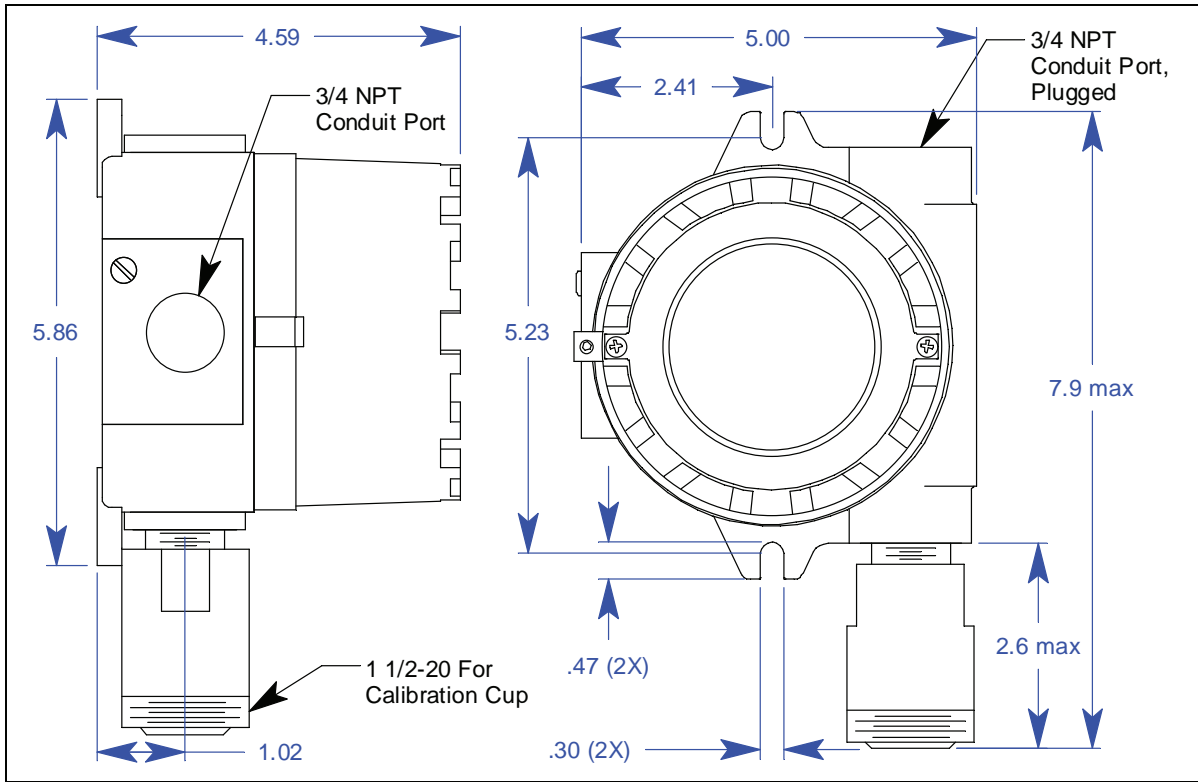

Figure 16: Outline & Mounting Dimensions, Oxygen, Partial Pressure Type

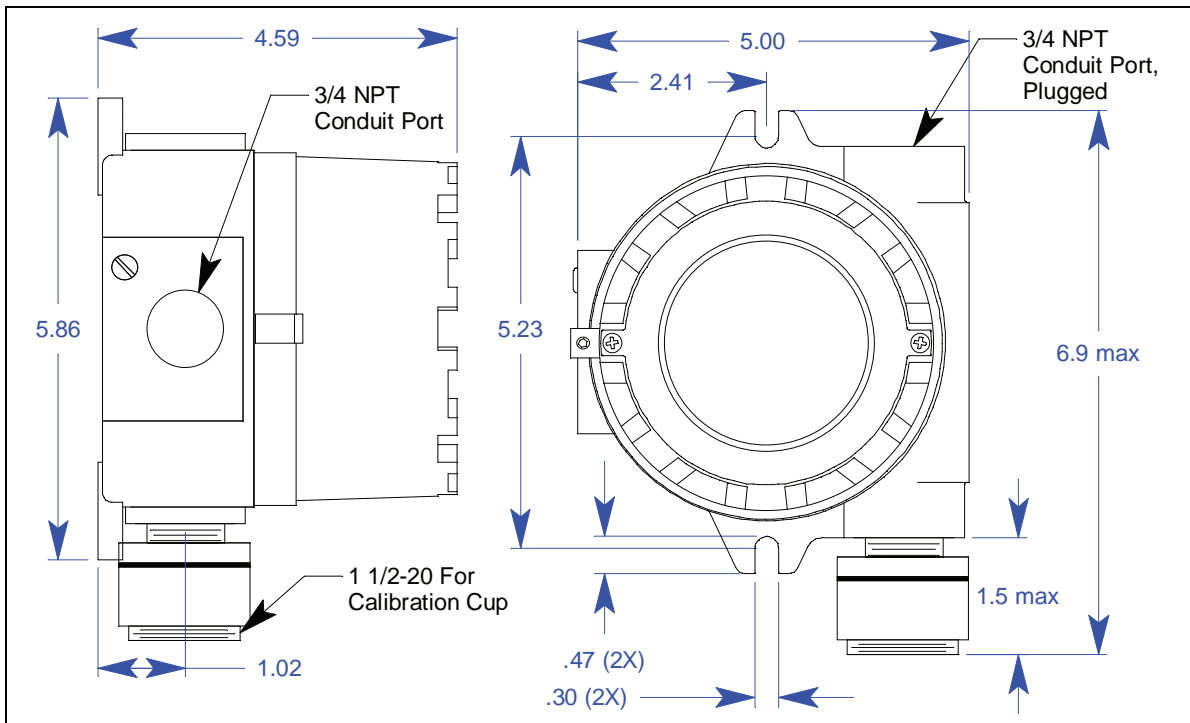

Figure 17: Outline & Mounting Dimensions, Replaceable Sensor, H₂S, CO, and Oxygen, Non Explosion Proof

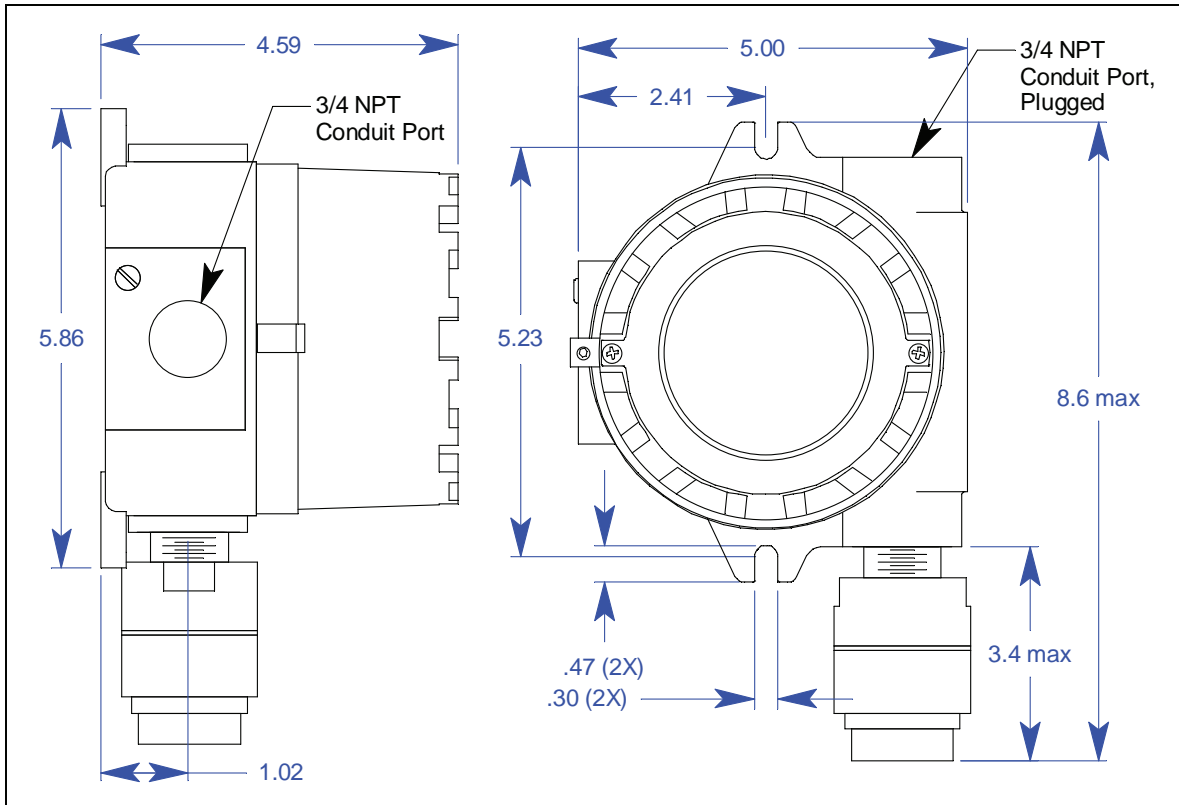

Figure 18: Outline & Mounting Dimensions, H₂S, CO, and Oxygen, CSA, Explosion-Proof

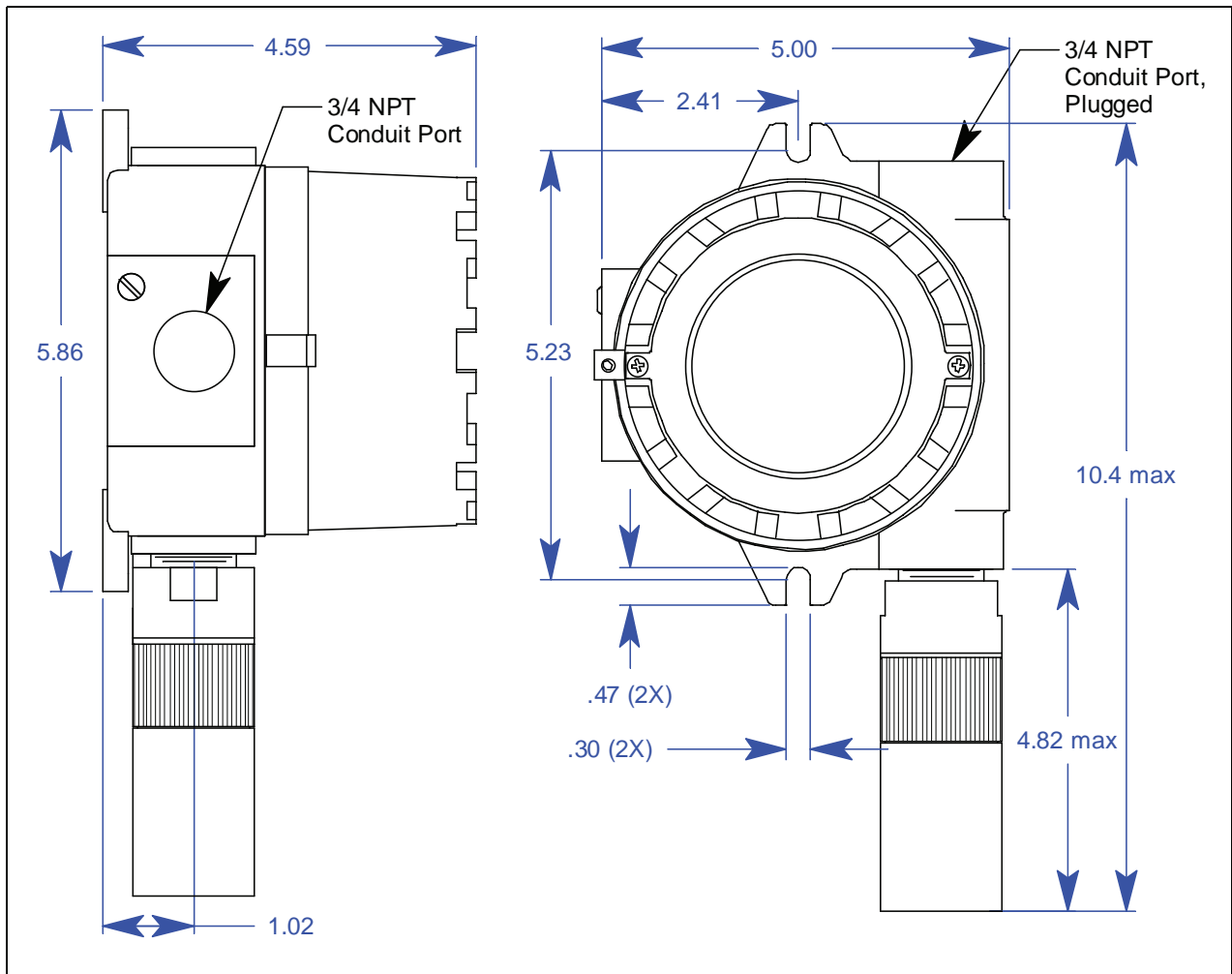

Figure 19: Outline & Mounting Dimensions, ESM-01 Toxic

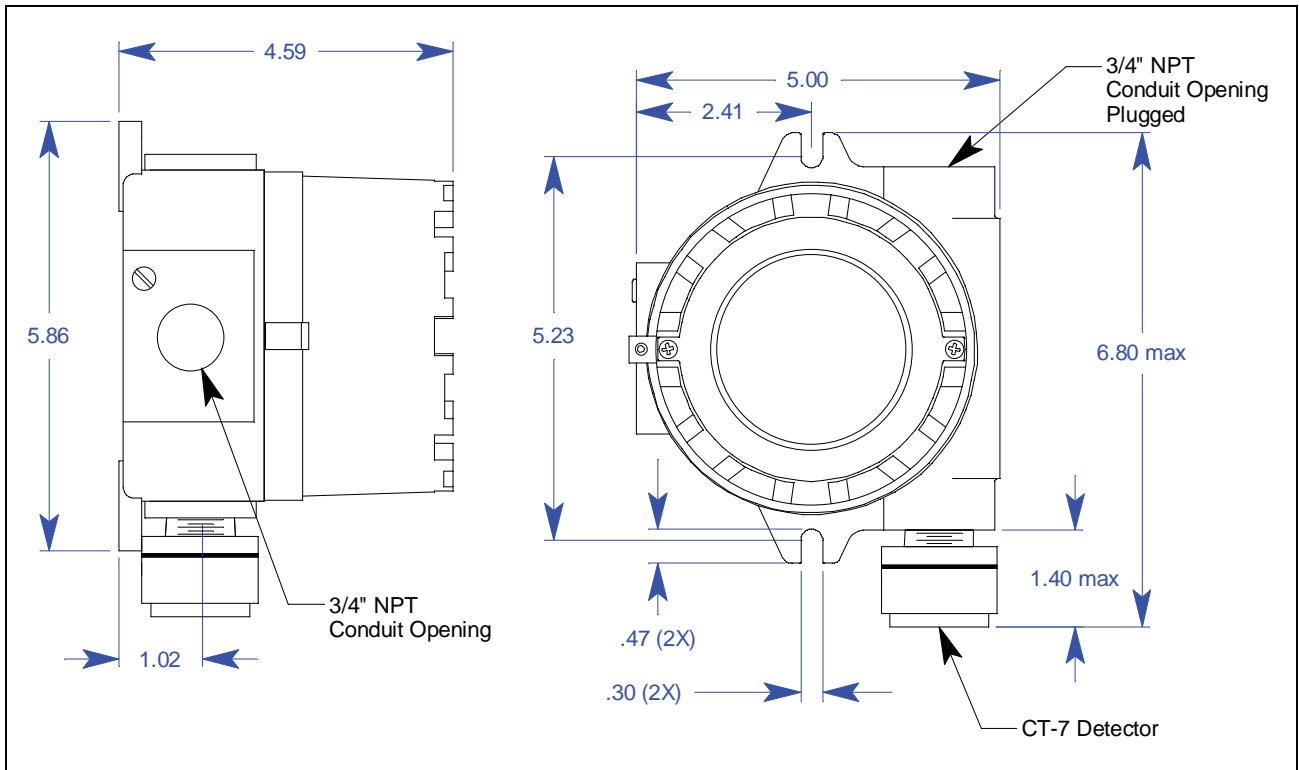

Figure 20: Outline & Mounting Dimensions, CT-7 Series

Wiring the M2A Transmitter

WARNING: Always verify that the power source is OFF before making any wiring connections.

1. Remove the junction box cover.
2. Grasp the control PCB by its edges.
3. Gently pull until the control PCB is pulled away from the banana jacks. Take care not to pull too hard and damage the cable which connects the control and terminal PCBs.
4. Let the control PCB hang by the cable. The terminal strips are now visible on the terminal PCB. The control PCB may be left hanging while wiring is done. If desired, the control PCB may be disconnected from the cable and set aside while wiring.
5. The detector leads are factory wired. Verify that the detector leads are wired to the detector terminal strip as shown in the applicable figure below:

Catalytic LEL/Catalytic ppm/IR Combustible/IR CO₂ Detectors

The wiring for these types of detectors is the same. Red wire to terminal labeled LEL R, white wire to terminal labeled LEL W, green wire to terminal labeled LEL G, black wire to terminal labeled LEL B.

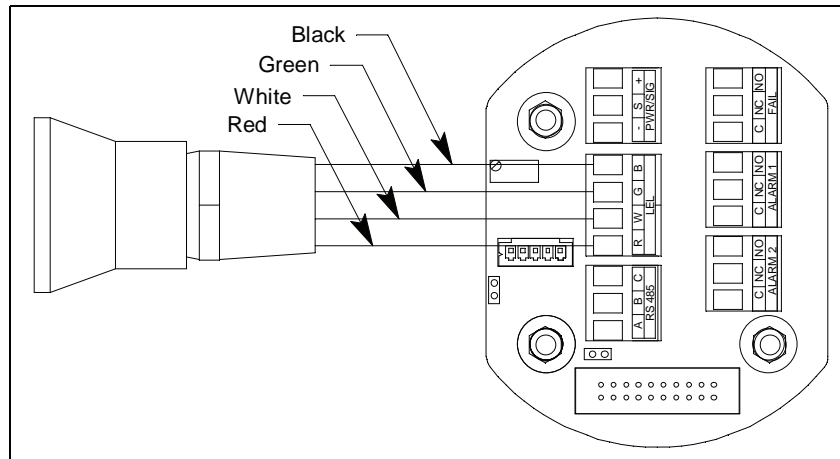

Figure 21: Catalytic LEL and ppm Detector Wiring

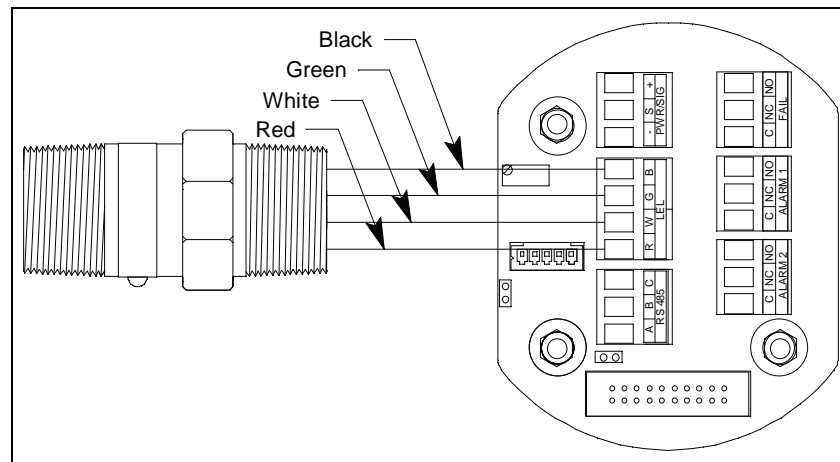

Figure 22: IR Combustible/IR CO₂ Detector Wiring

Oxygen Detectors: Partial Pressure, Capillary Type, and CSA Capillary Type

The wiring for all the oxygen detectors is the same. White wire to terminal labeled OXY +, green wire to terminal labeled OXY -.

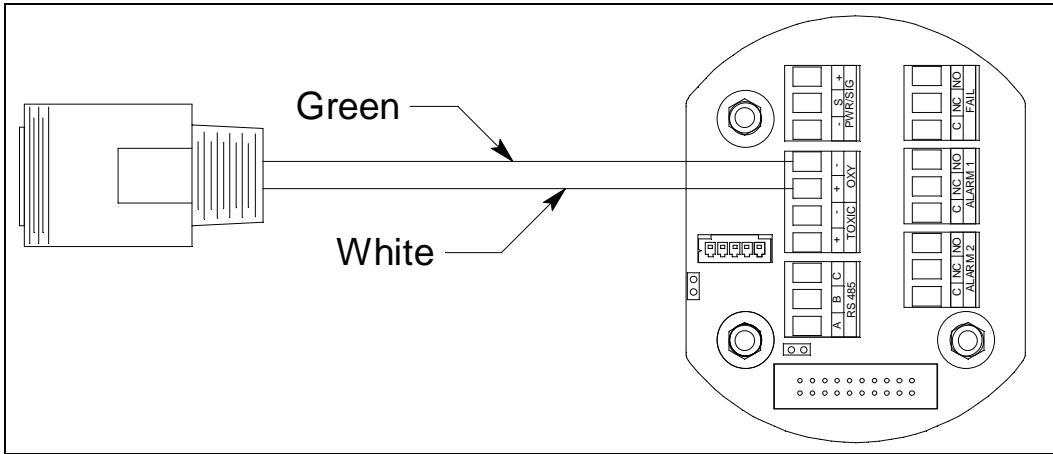

Figure 23: Partial Pressure Oxygen Detector Wiring

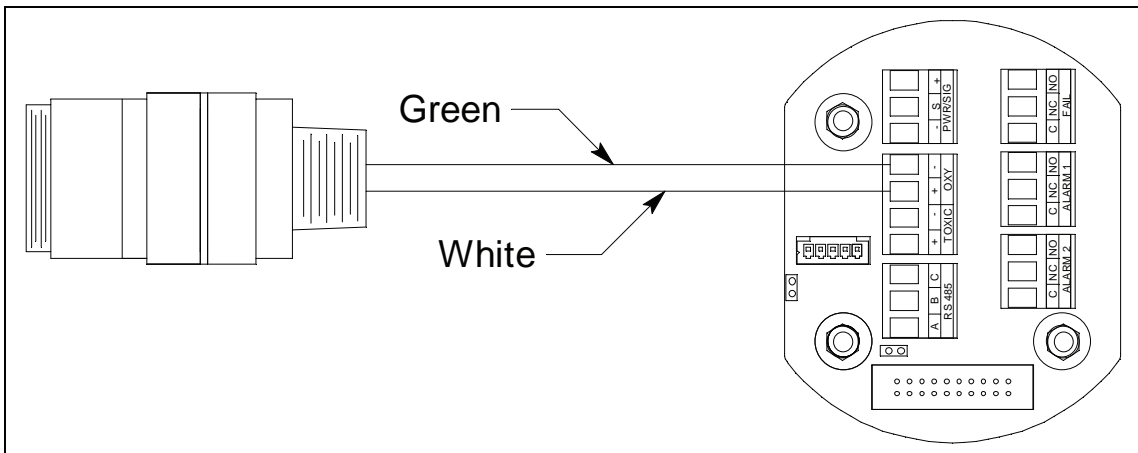

Figure 24: CSA Capillary Type Oxygen Detector Wiring

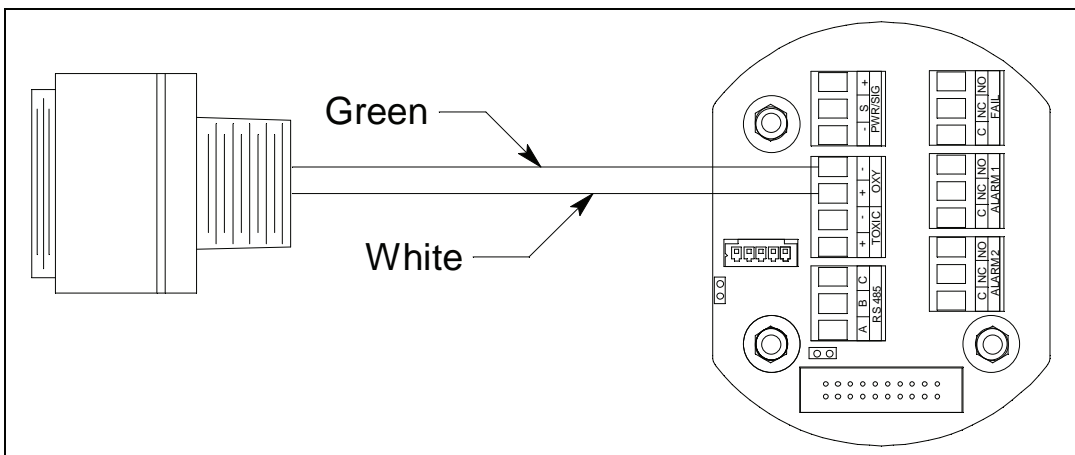

Figure 25: Capillary Type Replaceable Sensor Oxygen Detector Wiring

CSA Type CO or H₂S Gas Detectors

Red wire to terminal labeled TOXIC +, black wire to terminal labeled TOXIC -.

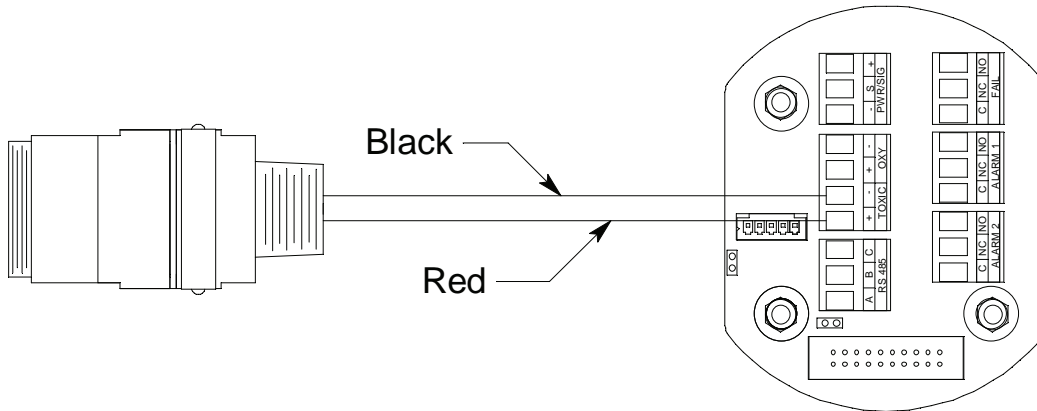

Figure 26: H₂S/CO Detector Wiring, CSA

Non Explosion Proof CO or H₂S Gas Detectors

Red wire to terminal labeled TOXIC +, black wire to terminal labeled TOXIC -.

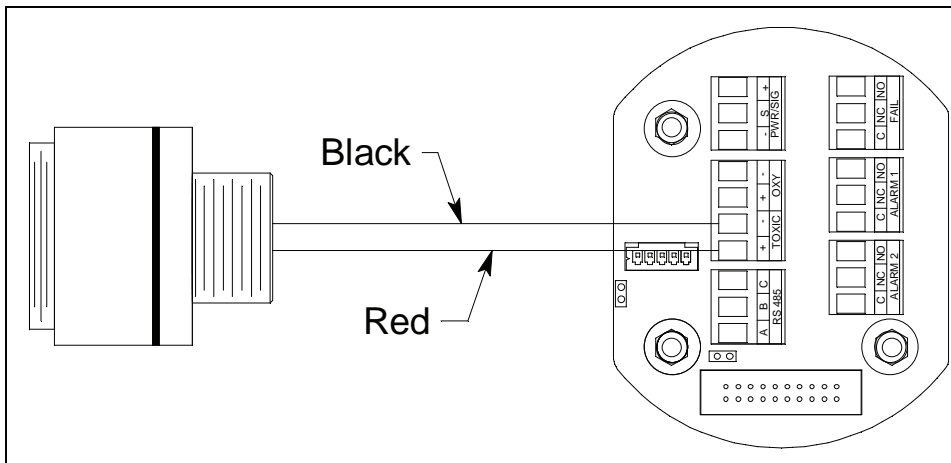

Figure 27: H₂S/CO Detector Wiring

ESM-01 Toxic Detectors

The ESM-01 toxic detectors have one black wire and one color coded wire. Connect the color coded wire (see chart below) to the terminal labeled TOXIC + and the black wire to the terminal labeled TOXIC -.

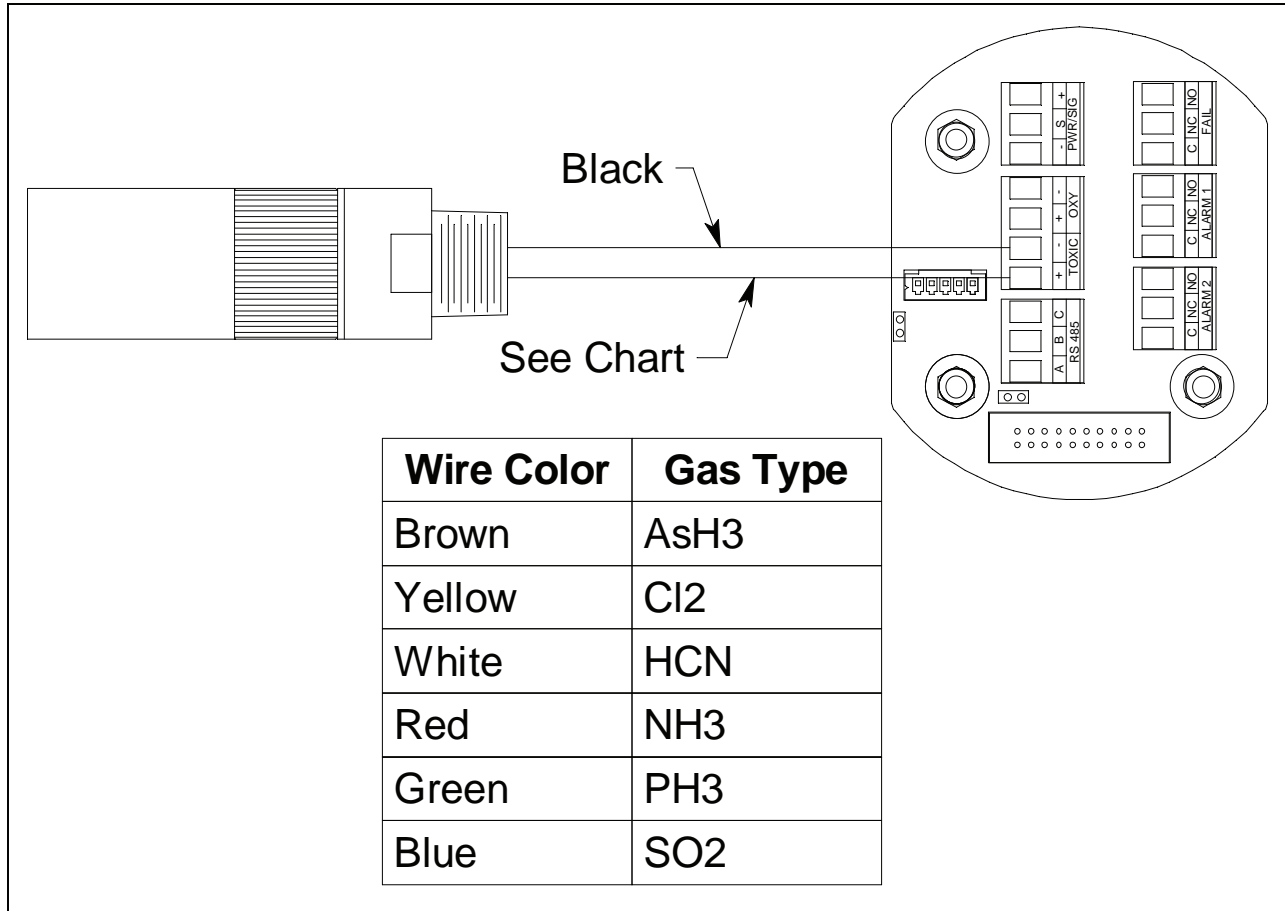

Figure 28: ESM-01 Toxic Detector Wiring

CT-7 Series Toxic Detectors

The CT-7 Series toxic detectors have one black wire and one color coded wire. Connect the color coded wire (see chart below) to the terminal labeled TOXIC + and the black wire to the terminal labeled TOXIC -.

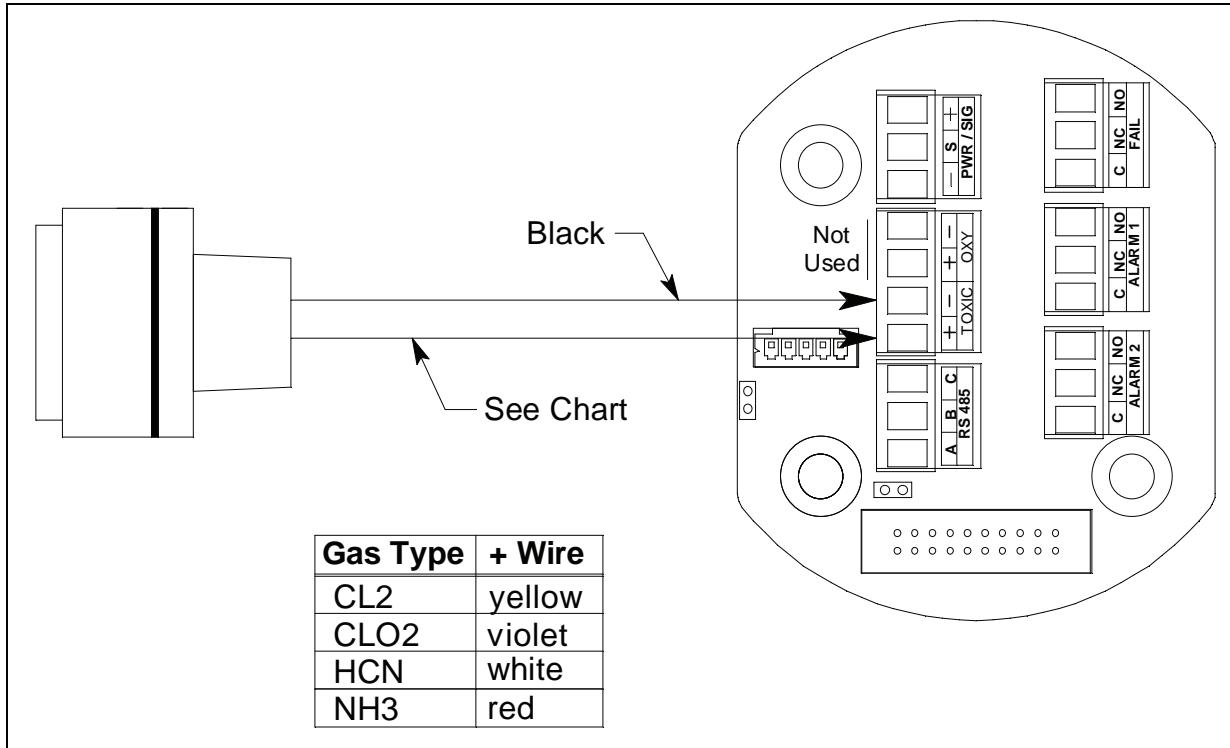

Figure 29: CT-7 Series Toxic Detector Wiring

- To gain access to a plug-in terminal strip for wiring, pull it out of its socket by grasping the wall between two terminal positions with needle nose pliers and pulling. Be careful not to exert too much force on the wall to avoid damage to the terminal strip. The detector terminal strip and the alarm 1 relay terminal strip may be removed by grasping them with your fingers if the adjacent terminal strips have been removed.

WARNING: *If the M2A is installed in a hazardous location, use appropriately rated conduit, conduit fittings, and appropriate construction technique that complies with the local electrical code. In addition, use appropriately rated conduit, conduit fittings, and appropriate construction technique to maintain the NEMA 4X environmental rating of the junction box and avoid water entering the junction box at the conduit ports.*

WARNING: *To maintain the explosion proof classification of the M2A, a conduit seal must be used within a certain distance of the junction box conduit hub used for wiring to the controller, as outlined in the table below.*

| Location | Detector | Conduit Seal Within |
|-------------------------|----------------------------|---|
| Group B Locations | All XP detectors | 2 inches for all environments |
| Group C and D Locations | Catalytic LEL (CSA) | 2 inches for all environments |
| | Catalytic LEL (UL) | 18 inches for all environments |
| | CO and H ₂ S XP | 2 inches for all environments |
| | IR non-replaceable XP | 18 inches for all environments |
| | IR replaceable XP | 18 inches for environments (do not install detector in environments with acetic acid) |
| | O ₂ XP | |

7. Guide multi conductor shielded cable or cables or wires in conduit through the conduit port on the left side of the junction box. The number of cables or wires needed will depend on whether the M2A is wired to a gas monitoring controller or just to power, whether any relays are used, and whether the Modbus output is used.

WARNING: *If the top conduit port is used for wiring, be sure to seal the threads to ensure water does not enter the junction box. A conduit seal, which is normally required to maintain the junction box's hazardous location rating, will also help to prevent water from entering through the top port.*

NOTE: If the M2A is being wired to a PLC or DCS device, see "Appendix B: PLC and DCS Device Wiring" on page 77, then continue with step 8.

8. Use the following recommendations to determine how to wire the M2A:
 - If Modbus connections will not be used and only the PWR/SIG connections will be used, use a two or three conductor shielded cable or two or three wires in conduit for connections to the power/signal terminal strip depending on whether or not the signal (S) terminal is used. The S terminal has a 4 - 20 mA output, but if you do not need to monitor this signal and do not connect to the S terminal to access this signal, the M2A will still function completely.

Table 9: Wire Size for PWR/SIG Connections

| Max Distance to Controller w/18 Gauge Wire | Max Distance to Controller w/16 Gauge Wire | Max Distance to Controller w/14 Gauge Wire |
|--|--|--|
| 2,500 ft. | 5,000 ft. | 8,000 ft. |

- If the PWR/SIG connections and one or more relays are used, route the connections to the M2A in conduit. Use shielded cable in the conduit for the PWR/SIG connections and unshielded cable or individual wires for the relay connections. Make sure any wire or cable used for relay wiring is appropriately rated for the power that it will carry.

NOTE: If shielded cable is used for the PWR/SIG connections, leave the cable shield's drain wire insulated and disconnected at the M2A. You will connect the opposite end of the cable's drain wire at the controller or device.

- If the M2A will be wired into a Modbus network, see "Chapter 8: RS-485 Modbus Output" on page 61. See Figure 30 below for field wiring connections to the M2A.

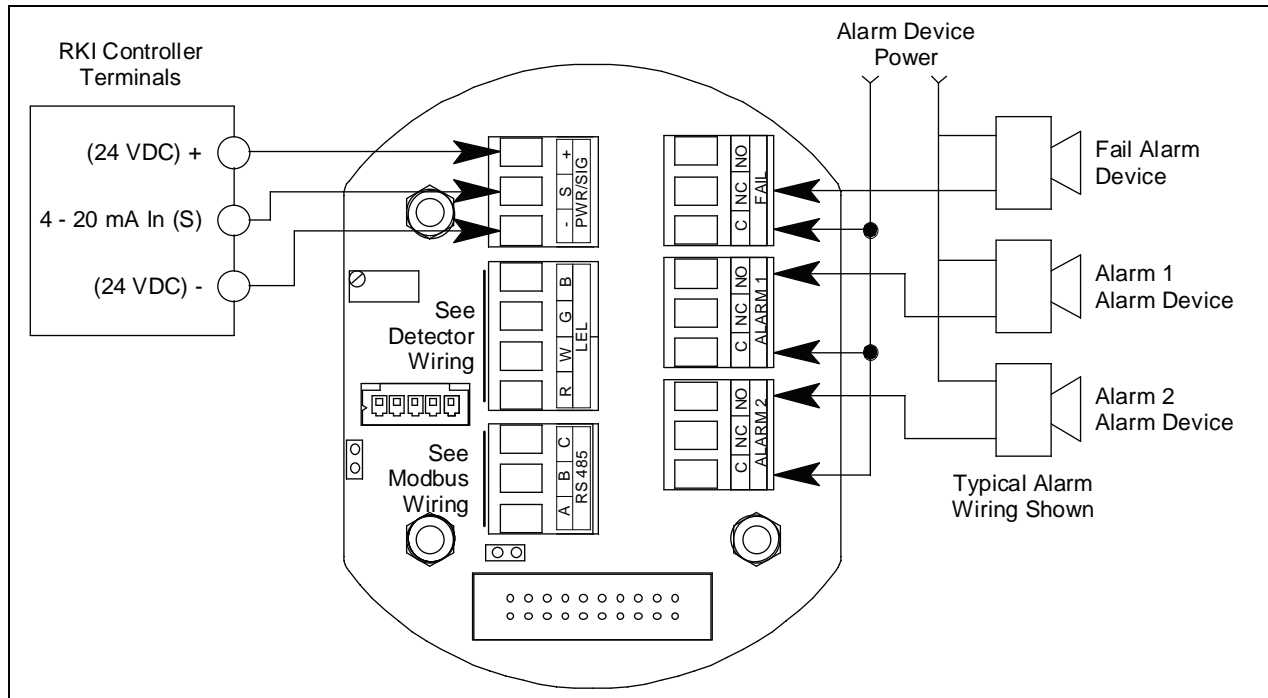

Figure 30: Wiring the M2A to a Controller and Alarm Devices

9. Re-install the control PCB (and ribbon cable if necessary). Be sure the ribbon cable is routed down below the control PCB so it will not be damaged by the cover when it is screwed back on.
10. Secure the junction box cover to the junction box.

11. Make controller, device, and relay connections as appropriate. If shielded cable is used for the PWR/SIG connections, connect the cable shield's drain wire to an available chassis ground at the gas monitoring controller, recording device, or programmable controller.

Start Up

Introducing Incoming Power

1. Complete the installation procedures described earlier in this manual.
2. Verify that all wiring connections are correct and secure.
3. Turn on the incoming power.
4. If necessary, turn on the controller or other monitoring device that is connected to the M2A.
5. The OLED display will indicate the firmware version when the M2A is first powered up and will then count down a one minute warm-up period before normal operation begins. During normal operation, the display will indicate the target gas and current gas reading. Verify that the display is indicating the target gas and current gas reading after the warm-up period is complete and normal operation begins.

METHANE
0 %LEL

NOTE: Allow the M2A's detector to warm up for 15 minutes before you continue with the next section, "Adjusting the Fresh Air Reading."

Adjusting the Fresh Air Reading

When the M2A is shipped from RKI Instruments, Inc., it is factory calibrated. If a full calibration is desired at startup, see "Calibration, Combustible Gas, CO₂, and Toxic Versions" on page 50 or "Calibration, Oxygen Version" on page 54.

Verify that the M2A is in a fresh air environment (environment known to be free of the target gas and combustible or toxic gas vapors and of normal oxygen content, 20.9%).

CAUTION: *If you suspect the presence of combustible gas, CO₂, toxic gas, or that the oxygen content is not normal in the monitoring environment, use the calibration kit and the zero air calibration cylinder to introduce "fresh air" to the detector and verify an accurate fresh air setting. See the "Calibration, Combustible Gas, CO₂, and Toxic Versions" on page 50 or "Calibration, Oxygen Version" on page 54 for instructions on how to use a zero air cylinder when performing a fresh air adjustment.*

Non-Intrusive Fresh Air Signal Adjustment

If the M2A is installed in a classified area and non-intrusive zero adjustment is required, follow the instructions below, **but do not remove the junction box cover**. Use the magnetic wand accessory to actuate the magnetic switches instead of pushing the control switch buttons. To actuate a magnetic switch and perform the same operation as pressing a control switch button, touch the magnet in the end of the magnetic wand to the M2A's glass cover directly over the magnetic switch you wish to actuate. Touching the glass and removing the wand is the same as pressing and releasing a button. Touching the glass and keeping the wand in place is the same as pressing and holding a button.

WARNING: *The M2A is not an active gas monitoring device during the fresh air adjustment procedure. The 4-20 mA output signal will “freeze” at 3.5 mA for a toxic, combustible gas, or CO₂ M2A, or at 17.4 mA for an oxygen M2A, and all relays will remain in their non-alarm state while the M2A is in Calibration Mode. The output signal will not indicate current readings and the relays will not resume operating normally until the M2A is in normal operation again.*

NOTE: While in the calibration program, if there is no switch activity for the calibration time-out period the unit will return to normal operation. The factory set time-out is 15 minutes. If you want a different time-out period, see “Viewing & Changing M2A Parameters” on page 42 for instructions to change the calibration time-out.

Combustible Gas, CO₂, and Toxic Versions, Adjusting the Fresh Air Reading

1. While in normal operation, press and hold the UP/YES button for 5 seconds to enter Calibration Mode. Release the button when the following screen appears.

| |
|------------------|
| Calib? YES/NO |
|------------------|

2. Press and release the UP/YES button to continue. The display will indicate the target gas and **CAL Mode** for a few seconds before showing **FreshAir Adjust?**.
3. Press and release the UP/YES button. **ENTER** will alternate with **FreshAir** on the top display line and the current gas reading will be on the bottom display line.
4. Press and release the ENTER button. The M2A will perform a zero operation and the display will indicate **SPAN w/Cal Gas?**.
5. Press and release the DOWN/NO button. The display will indicate **Leaving CAL Mode** and the M2A will return to normal operation.

Oxygen Version, Adjusting the Fresh Air Reading

1. While in normal operation, press and hold the UP/YES button for 5 seconds to enter Calibration Mode. Release the button when the following screen appears.

| |
|------------------|
| Calib? YES/NO |
|------------------|

2. Press and release the UP/YES button to continue. The display will indicate **OXYGEN CAL Mode** for a few seconds before showing **FreshAir Adjust?**.
3. Press and release the UP/YES button. **ENTER** will alternate with **FreshAir** on the top display line and the current oxygen reading will be on the bottom display line.
4. Press and release the ENTER button. The M2A will perform a span operation and then the display will indicate **ZERO w/Cal Gas?**.
5. Press and release the DOWN/NO button. The display will indicate **Leaving CAL Mode** and the M2A will return to normal operation.

Chapter 4: Operation

Overview

This chapter describes the M2A in normal operation. This chapter also describes the M2A in alarm 1, alarm 2, and fail conditions and suggests responses to these conditions.

Normal Operation

Normal operation is defined as follows:

- The start-up procedure is complete.
- The M2A is not indicating an alarm 1, alarm 2, or fail condition.
- The M2A is not in Calibration, Configuration, or Gas Type modes.

During normal operation, the M2A simultaneously displays the current gas reading, unit of measure, and target gas. The example below illustrates a typical combustible gas M2A.

METHANE
0 %LEL

Information Screen

The Information Screen displays the M2A's operating voltage and firmware and hardware information. To display the Information Screen, do the following:

1. Press and hold the DOWN/NO button for 3 seconds. The Information Screen will appear.

24.2V
v6.0L 2A

2. Continue holding the DOWN/NO button to keep the Information Screen on the display. The top line indicates the operating voltage that is connected to the M2A. The second line indicates the firmware that is running, version 6.0 in this example, and the M2A's hardware version, version 2A in this example. This information may be useful if you need to contact the factory with questions about the M2A.
3. Release the DOWN/NO button when you are done viewing the Information Screen. The display will return to the normal operation screen within a couple of seconds.

4 - 20 mA Signal Output Operation

The output at the S terminal of the power/signal terminal strip is a 4 - 20 mA signal that corresponds to the detection range of the M2A. During normal operation, this signal tracks the gas concentration on the OLED display.

There are several circumstances where the signal output will not track the display reading but will behave as follows:

- When the M2A is in its warm-up period, the signal output will be fixed at 1.2 mA.

- When the M2A's gas type is changed, the M2A will enter Configuration Mode for you to verify the parameter settings. When you exit Configuration Mode, the display will indicate **NEEDS CALIBRATION** and will continue to indicate this until Calibration Mode is entered and a calibration is performed. In this situation, the signal output will be fixed at 3.5 mA for LEL and toxic versions and 17.4 mA for oxygen versions from the time Gas Type Mode is entered until the M2A is calibrated and returns to normal operation.
- If you enter Calibration Mode, Configuration Mode, Gas Type Mode, or Modbus Mode, the signal output will be fixed at 3.5 mA for combustible gas, CO₂, and toxic versions and 17.4 mA for oxygen versions until the M2A returns to normal operation.
- If the M2A's input power decreases below 9.5 volts so that the M2A is in a low power alarm, the signal output is fixed below 2.4 mA until the low power alarm is cleared.
- If the M2 goes into a fail condition, after a 30 second delay, the signal output is fixed below 2.4 mA until the fail alarm is cleared. During the 30 second delay, the signal output follows the detector output. In the case of a downscale reading, the display and the signal output continue to track the reading down to -99% of full scale (1.15 mA).

Alarm Indications

NOTE: The M2A includes alarm on and alarm off delay settings for alarm 1 and alarm 2. The alarm indications described in this section operate according to the factory set alarm settings. See Table 11 on page 43 for all the factory settings.

Table 10: Visual and Audible Alarm Indications

| Condition | Cause | Visual Indication(s) |
|---|---|---|
| Alarm 1 ¹ | Increasing (decreasing for O ₂) gas reading at or above the alarm 1 setpoint | <ul style="list-style-type: none"> • A1 LED is on • Gas reading alternates with ALARM-1 message |
| Alarm 2 ¹ | Increasing gas reading at or above the alarm 2 setpoint | <ul style="list-style-type: none"> • A2 LED is on • Gas reading alternates with ALARM-2 message |
| Fail | <ul style="list-style-type: none"> • Disconnected or misconnected detector wiring • The plug-in sensor is not properly plugged into the socket in the detector housing body. <p><i>NOTE: It could take up to 40 minutes for a disconnected CT-7 style NH₃ plug-in sensor to trigger a fail condition.</i></p> <ul style="list-style-type: none"> • Display reading at -10% of full scale or lower • Defective components | <ul style="list-style-type: none"> • F LED is on • FAIL message replaces gas reading <p><i>NOTE: There is a 30 second delay on the fail condition.</i></p> |
| Low Power | DC power source less than 9.5 volts. | <ul style="list-style-type: none"> • F LED is on • LowPower message and actual voltage of incoming DC power |
| * ¹ If the M2A is in both an alarm 1 and an alarm 2 condition, both alarm LEDs are on and the display alternates between the gas reading and the ALMS 1&2 message. | | |

NOTE: You can select normally energized (N. EN) or normally de-energized (N. DE-EN) alarm 1 and alarm 2 relay settings in Configuration Mode. The following sections describe the standard factory setting for these relays which is N. DE-EN.

The fail relay is factory set as N. EN and is not user-adjustable.

Alarm 1 Condition

Alarm 1 Condition Indications

When the gas reading reaches the alarm 1 setpoint, the M2A senses an alarm 1 condition. The M2A alerts you to an alarm 1 condition as follows:

- The A1 LED turns on.
- The gas reading alternates with the **ALARM-1** message.
- The alarm 1 relay energizes.

Responding to an Alarm 1 Condition

1. Follow your established procedure for a low level combustible or toxic gas condition or a decreasing oxygen concentration condition.
2. After the gas reading falls below (above for oxygen) the alarm 1 setpoint, press the ENTER button to reset the alarm 1 circuit. Resetting the alarm 1 circuit turns off the A1 LED, resets the OLED display, and de-energizes the alarm 1 relay.

NOTE: If the ENTER button is pressed while the M2A is in an alarm 1 condition, the A1 LED will flash but all other indications will remain unchanged.

You cannot de-energize the alarm 1 relay until the gas reading falls below (above for oxygen) the alarm 1 setpoint.

Alarm 2 Condition

Alarm 2 Condition Indications

When the gas reading reaches the alarm 2 setpoint, the M2A senses an alarm 2 condition. The M2A alerts you to an alarm 2 condition as follows:

- The A2 LED turns on.
- The gas reading alternates with the **ALARM-2** message.
- The alarm 2 relay energizes.

NOTE: If the M2A is in both an alarm 1 and alarm 2 condition, both the A1 and A2 LEDs will be on, the gas reading will alternate with the **ALMS 1&2** message, and both alarm relays will energize.

Responding to an Alarm 2 Condition

1. Follow your established procedure for a high level combustible or toxic gas condition or an increasing oxygen concentration condition.
2. After the gas reading falls below the alarm 2 setpoint, press the ENTER button to reset the alarm circuit. Resetting the alarm circuit turns off the A2 light, resets the OLED display, and de-energizes the alarm 2 relay.

NOTE: If the ENTER button is pressed while the M2A is in an alarm 2 condition, the A2 LED will flash but all other indications will remain unchanged.

You cannot de-energize the alarm 2 relay until the gas reading falls below the alarm 2 setpoint.

Fail Condition

Fail Condition Indications

The M2A indicates a fail condition for any of the following:

- The detector wiring is disconnected or incorrectly connected.
- The plug-in sensor is not properly plugged into the socket in the detector housing body.

NOTE: It could take up to 40 minutes for a disconnected CT-7 style NH₃ plug-in sensor to trigger a fail condition.

- The display reading is -10% of full scale or lower.

When the M2A senses a fail condition, it alerts you as follows:

- The F LED turns on.
- The gas reading is replaced by the **FAIL** message.
- The fail relay de-energizes.

NOTE: The fail alarm has a 30 second delay.

Responding to a Fail Condition

1. Verify that the detector wiring is correctly and securely connected.
2. If the M2A has a replaceable plug-in sensor, verify that the replaceable plug-in sensor in the detector housing is properly installed.

Low Power Alarm

Low Power Alarm Indications

The M2A senses a low power condition when the DC power source is 9.5 volts or less.

WARNING: *While in a low power condition, the M2A is not an active gas monitor.*

When the M2A senses a low power condition, it alerts you as follows:

- The F LED turns on.
- The message **LowPower** is indicated on the top line of the OLED display and the input voltage is displayed on the bottom line of the OLED display.
- The fail relay de-energizes.

NOTE: The low power alarm cannot be cleared using the ENTER button.

When the voltage increases to 10.0 volts, the low power alarm is cleared and the M2A will begin its warm-up sequence.

Responding to a Low Power Condition

1. Determine and correct the cause of the low power condition.
2. When the input power increases above 10.0 volts, the M2A will begin its warm-up sequence.
3. Verify that the M2A enters normal operation after its warm-up sequence. If necessary, perform a fresh air adjustment. See “Adjusting the Fresh Air Reading” on page 35.

Chapter 5: Configuration Mode

Overview

This chapter describes how to view and change M2A parameters using Configuration Mode. It is accessed using the program buttons.

Configuration Mode includes a 5-minute time-out feature. If you do not press a control button for 5 minutes, the M2A automatically returns to normal operation.

NOTE: If the M2A returns to normal operation because of a time-out, it enters a warm-up period just as it does when it is first turned on.

If you are installing a new M2A, it has been setup at the factory. Use Configuration Mode only if you want to change the M2A's setup. If you want to change the detector type see "Chapter 6: Gas Type Mode" on page 45.

Viewing & Changing M2A Parameters

1. While in normal operation, simultaneously press and hold the UP/YES and ENTER buttons for 5 seconds to enter Configuration Mode. Release the buttons when the following screen appears.

Enter
Config?

2. If you want to exit Configuration Mode, press and release the DOWN/NO button and the M2A will return to normal operation.

If you want to continue in Configuration Mode, press and release the UP/YES button. The target gas and the full scale will be displayed for a few seconds before the first adjustable parameter, the alarm 1 setpoint, is displayed.

3. If you want to change the currently displayed parameter, use the UP/YES and DOWN/NO buttons to adjust it to the desired setting, then press ENTER to continue to the next parameter.

If the currently displayed parameter is OK, press the ENTER button to proceed to the next parameter.

Table 11 lists the M2A parameters you can set. Table 11 also lists the factory set value for each parameter.

Table 11: Configuration Parameters

| Parameter (Factory Set Value) | Description |
|---|--|
| ALARM-1 (level) (See Table 1 on page 7) | The gas reading at which the M2A initiates an alarm 1 condition. |
| ALARM-1 (activation) (Decrease for oxygen M2A, Increase for all other types) | Indicates if the alarm 1 circuit is activated by gas readings increasing (Increase) or decreasing (Decrease) to the ALARM-1 Level. |
| ALARM-1 (relay action) (N. DE-EN) | If set as N. DE-EN , the alarm 1 relay is de-energized in normal operation and energizes when an alarm 1 condition is initiated. If set as N. EN , the alarm 1 relay is energized in normal operation and de-energizes when an alarm 1 condition is initiated. |
| ALARM-1 (relay reset) (LATCH) | If set as LATCH , you must press the ENTER button to reset the alarm 1 circuit after the alarm 1 condition passes. If set as SELF-RST , the M2A automatically resets the alarm 1 circuit after the alarm 1 condition passes. |
| A1 OnDy (alarm 1 on delay) (1 secs) | The amount of time the M2A delays activation of the alarm 1 circuit once an alarm 1 condition is initiated. It can be set in 1 second increments from 0 - 60 seconds, in 1 minute increments from 1 - 15 minutes, and in 15 minute increments from 15 - 60 minutes. |
| A1 OffDy (alarm 1 off delay) (0 sec.) | The amount of time the M2A delays turning off the alarm 1 circuit once an alarm 1 condition passes. This parameter appears only if the alarm 1 relay reset setting is set to SELF-RST . It can be set in 1 second increments from 0 - 60 seconds, in 1 minute increments from 1 - 15 minutes, and in 15 minute increments from 15 - 60 minutes. |
| ALARM-2 (level) (See Table 1 on page 7) | The gas reading at which the M2A initiates an alarm 2 condition. |
| ALARM-2 (activation) (Increase for all types) | Indicates if the alarm 2 circuit is activated by gas readings increasing (Increase) or decreasing (Decrease) to the ALARM-1 Level. |
| ALARM-2 (relay action) (N. DE-EN) | If set as N. DE-EN , the alarm 2 relay is de-energized in normal operation and energizes when an alarm 2 condition is initiated. If set as N. EN , the alarm 2 relay is energized in normal operation and de-energizes when an alarm 2 condition is initiated. |
| ALARM-2 (relay reset) (LATCH) | If set as LATCH , you must press the ENTER button to reset the alarm 2 circuit after the alarm 2 condition passes. If set as SELF-RST , the M2A automatically resets the alarm 2 circuit after the alarm 2 condition passes. |
| A2 OnDy (alarm 2 on delay) (1 secs) | The amount of time the M2A delays activation of the alarm 2 circuit once an alarm 2 condition is initiated. It can be set in 1 second increments from 0 - 60 seconds, in 1 minute increments from 1 - 15 minutes, and in 15 minute increments from 15 - 60 minutes. |
| A2 OffDy (alarm 2 off delay) (0 sec.) | The amount of time the M2A delays turning off the alarm 2 circuit once an alarm 2 condition passes. This parameter appears only if the alarm 2 relay reset setting is set to SELF-RST . It can be set in 1 second increments from 0 - 60 seconds, in 1 minute increments from 1 - 15 minutes, and in 15 minute increments from 15 - 60 minutes. |

Table 11: Configuration Parameters

| Parameter (Factory Set Value) | Description |
|---|--|
| ZeroSupp (0.0% of the detection range in terms of the detection units for carbon dioxide channel types, 0.5% oxygen for oxygen types, 1% of the detection range for the 0-9000 ppm CH ₄ range, 2% of the detection range in terms of the detection units for all other types) | The zero suppression feature helps prevent “jumpy” readings near the fresh air reading. For example, if the zero suppression setting for a combustible LEL detector is 2.0% LEL , the M2A will display a reading of 0% LEL for gas readings from -2% LEL to 2% LEL. It is settable from 0 to 6% of the detection range. |
| FILTER (5 secs) | The filter feature helps “smooth out” jumpy or noisy signals from the detector. You can set the filter from 0 seconds to 60 seconds in 5 seconds increments. The displayed gas reading is the average reading over the previous time period defined by the filter setting. So if the filter is set to 5 seconds, the displayed gas reading is the average over the past 5 seconds. |
| CAL Time (15 mins) | The calibration time-out sets the amount of time after the last button push while in Calibration Mode that the M2A will wait before returning to normal operation. If the calibration time-out is set to 15 mins , then M2A will return to normal operation automatically 15 minutes after the last button push. |
| Auto Zero (Disabled for carbon dioxide channels; Enabled for all other channel types) | If set to Enabled , the M2A’s firmware will monitor the zero (fresh air) reading and make automatic zero adjustments under precisely specified conditions if it determines that a reading change is due to normal sensor drift. If set to Disabled , the Auto Zero function is turned off. |

4. When you have scrolled through all the adjustable parameters, **SAVE IT? YES/NO** appears on the display.
5. If you do not wish to save the adjustments and want to exit Configuration Mode, press and release the DOWN/NO button. The **DO OVER? YES/NO** message will display. Press and release the DOWN/NO button. The **ABORT? YES/NO** message will display. Press the UP/YES button to return to normal operation.

If you wish to change some of the adjustments made, press and release the DOWN/NO button. The **DO OVER? YES/NO** message will display. Press and release the UP/YES button. The **Re-do Config** message will display and the M2A will return to the first adjustable parameter. Go back to step 3 and continue.

If you wish to save the adjustments made, press and release the UP/YES button. **Config Saved** is indicated on the display for a few seconds and the M2A returns to normal operation.

Chapter 6: Gas Type Mode

Overview

This chapter describes how to use Gas Type Mode to select the M2A's gas type. The gas type determines the target gas and detection range. The combustible gas/CO₂ and toxic/oxygen M2As have a different terminal PCB and run on different firmware. Your M2A will only have gas type choices available that it can support.

Gas Type Mode includes a 5-minute time-out feature. If you do not press a button for 5 minutes, the M2A automatically returns to normal operation.

NOTE: If the M2A enters normal operation because of a program time-out, it enters a warm-up period just as it does when it is first turned on.

Selecting the Gas Type

1. While in normal operation or during the warm-up sequence, press and hold the UP/YES and DOWN/NO buttons for five seconds. Release them when the following screen appears.

Select
GasType?

2. If you want to exit Gas Type Mode, press and release the DOWN/NO button. The display will indicate **NO CHANGE** and the M2A will return to normal operation.

If you want to continue in Gas Type Mode, press and release the UP/YES button. The top display line will indicate **GasType?** and the bottom display line will indicate the target gas choice.

3. Use the UP/YES or DOWN/NO button to scroll through the choices of target gas. Table 12 and Table 13 below list the choices of target gas for the M2A.

Table 12: Combustible Gas/CO₂ Gas Types

| Gas Type Choices | Detection Range |
|------------------|-----------------|
| HC | 0 - 100% LEL |
| iBUTANE | 0 - 100% LEL |
| PROPANE | 0 - 100% LEL |
| HEXANE | 0 - 100% LEL |
| HYDROGEN | 0 - 100% LEL |
| METHANE | 0 - 100% Volume |
| METHANE | 0 - 100% LEL |
| CO2 | 0 - 5,000 ppm |
| CO2 | 0 - 9,000 ppm |

Table 12: Combustible Gas/CO₂ Gas Types

| Gas Type Choices | Detection Range |
|--|------------------------|
| CO ₂ | 0 - 100% volume |
| CO ₂ | 0 - 50.0% volume |
| CO ₂ | 0 - 5.00% volume |
| METHANE | 0 - 5.00% volume |
| METHANE | 0 - 8980 ppm* |
| *Use this gas type for 0-9000 ppm CH ₄ . 8980 ppm is the highest displayed value. Anything higher is displayed as OVER . | |

Table 13: Toxic/Oxygen Gas Types

| Gas Type Choices | Detection Range |
|-------------------------|------------------------|
| H ₂ S | 0 - 100 ppm |
| CO | 0 - 300 ppm |
| CO | 0 - 200 ppm |
| CO | 0 - 100 ppm |
| CL ₂ | 0 - 3.00 ppm |
| CL ₂ | 0 - 10.0 ppm |
| NH ₃ | 0 - 75.0 ppm |
| SO ₂ | 0 - 6.00 ppm |
| ASH ₃ | 0 - 1.50 ppm |
| H ₂ S | 0 - 50.0 ppm |
| CLO ₂ | 0 - 1.00 ppm |
| CLO ₂ | 0 - 3.00 ppm |
| NH ₃ | 0 - 500 ppm |
| NH ₃ | 0 - 200 ppm |
| HCN | 0 - 15.0 ppm |
| CLO ₂ | 0 - 5.00 ppm |
| CL ₂ | 0 - 5.00 ppm |
| NH ₃ | 0 - 100 ppm |
| PH ₃ | 0 - 1.00 ppm |
| SIH ₄ | 0 - 15.0 ppm |

Table 13: Toxic/Oxygen Gas Types

| Gas Type Choices | Detection Range |
|-------------------------|------------------------|
| OXYGEN | 0 - 25.0% volume |

NOTE: Consult factory for availability of detectors for toxic M2A types not listed in Table 1 on page 7.

4. When the desired target gas is on the display, press and release the ENTER button. The display will ask **SAVE IT? YES/NO**.
5. To discard the gas type change, press and release the DOWN/NO button. The display will ask **DO OVER? YES/NO**. Press the DOWN/NO button. The display will ask **ABORT? YES/NO**. Press the UP/YES button. The M2A will return to normal operation without changing the gas type.

To save the gas type, press and release the UP/YES button. The display will indicate **Gas Type Updated**, the display will indicate the target gas and the detection range for a few seconds, and then the M2A will enter Configuration Mode automatically so that the parameter settings in Configuration Mode can be verified or changed.
6. While in Configuration Mode press and release the ENTER button to accept the displayed parameter setting and move to the next one. Use the UP/YES and DOWN/NO buttons to adjust a setting. See “Chapter 5: Configuration Mode” on page 42 for a complete description of Configuration Mode.
7. When you have reviewed and accepted the last item in Configuration Mode by pressing the ENTER button, display will ask **SAVE IT? YES/NO**.
8. To save the configuration settings, press and release the UP/YES button. The display will indicate **Config Saved** and the M2A will begin its warm-up sequence.

To discard the settings and review them again, press the DOWN/NO button. The display will ask **DO OVER? YES/NO**. Press the UP/YES button and the display will indicate **Re-do Config**, then display the target gas and the detection range for a few seconds before returning to Configuration Mode. Repeat steps 6 - 8 until the settings are as desired.
9. After the M2A completes its warm-up sequence, the display will indicate **CAL NEEDED**. Since the gas type has been changed, a successful calibration must be performed before the M2A can enter normal operation.
10. Press and release the UP/YES button to enter Calibration Mode. Normally, you must hold the UP/YES button for 5 seconds to enter Calibration Mode, but since a calibration is required, only a momentary push is needed to enter Calibration Mode after changing the gas type.
11. See “Calibration, Combustible Gas, CO2, and Toxic Versions” on page 50 or “Calibration, Oxygen Version” on page 54 for calibration instructions.

NOTE: When calibrating an M2A after changing the gas type, the M2A will not ask if you want to calibrate, or whether you want to perform a fresh air adjustment, span adjustment or zero adjustment. Since a complete calibration is required, the calibration sequence will proceed without asking if you want to perform certain operations.

Chapter 7: Maintenance

Overview

This chapter describes procedures for performing preventive maintenance, troubleshooting, calibrating the M2A, and replacing field replaceable parts. It includes separate procedures for calibrating the combustible gas/CO₂/toxic and oxygen versions of the M2A.

Preventive Maintenance

This section describes a recommended preventive maintenance schedule to ensure the optimum performance of the M2A. It includes daily, quarterly, and biannual procedures.

Daily

Verify a display reading of zero (20.9% for an oxygen M2A). Investigate significant changes in the reading.

Quarterly

Calibrate M2As that do not have an IR detector as described in “Calibration, Combustible Gas, CO₂, and Toxic Versions” on page 50 or “Calibration, Oxygen Version” on page 54. See “Calibration Frequency” on page 50 for a discussion of calibration frequency guidelines.

Biannually

Calibrate M2As that have an IR detector as described in “Calibration, Combustible Gas, CO₂, and Toxic Versions” on page 50. See “Calibration Frequency” on page 50 for a discussion of calibration frequency guidelines.

Troubleshooting

The troubleshooting guide describes symptoms, probable causes, and recommended action for problems you may encounter with the M2A.

NOTE: This troubleshooting guide describes M2A problems only. If the M2A is connected to a controller, see the controller operator’s manual for problems you may encounter with the controller.

Table 14: Troubleshooting the M2A

| Condition | Symptom(s) | Probable Causes | Recommended Action |
|-----------|---|--|--|
| No Power | The display backlight is off and the display screen is blank. | <ul style="list-style-type: none">The power wiring is disconnected or misconnected.The display cable is disconnected or misconnected. | <ol style="list-style-type: none">Verify that the wiring to the power source or controller is correct and secure.Verify that the ribbon cable connecting the terminal PCB to the control PCB is securely installed. This ribbon cable plugs into a connector on the top edge of the control PCB and on the bottom of the terminal PCB.If the power difficulties continue, contact RKI for further instruction. |

Table 14: Troubleshooting the M2A

| Condition | Symptom(s) | Probable Causes | Recommended Action |
|--|---|--|--|
| Frequent or Suspect Alarms | The M2A alerts you to frequent or suspect alarms while the fresh air readings remain on zero (20.9 for oxygen). | <ul style="list-style-type: none"> The M2A is experiencing false readings due to RFI or EMI. The detector wiring is disconnected, misconnected, or intermittent. | <ol style="list-style-type: none"> Verify that the M2A wiring is properly shielded. See “Wiring the M2A Transmitter” on page 28. Verify that the detector wiring is correct and secure. Increase the alarm on delay setting in Configuration Mode. If the frequent or suspect alarm difficulties continue, contact RKI for further instruction. |
| Flickering Display | The display reading flickers often. | <ul style="list-style-type: none"> The M2A is experiencing false readings due to RFI or EMI. The noise filter setting is too low. The zero suppression setting is too low. The display screen is malfunctioning. | <ol style="list-style-type: none"> Verify that the M2A wiring is properly shielded. See “Wiring the M2A Transmitter” on page 28. Verify that the detector wiring is correct and secure. Increase the filter setting in Configuration Mode. Increase the zero suppression setting in Configuration Mode. If the display difficulties continue, contact RKI for further instruction. |
| Fail Condition | <ul style="list-style-type: none"> M2A indicates a fail condition. Controller indicates a fail condition | <ul style="list-style-type: none"> The detector wiring to the terminal PCB is disconnected or misconnected. The wiring from the M2A to the controller is disconnected or misconnected. The detector fresh air signal is low enough to cause a fail condition. The detector is malfunctioning. The terminal or display PCB is malfunctioning. | <ol style="list-style-type: none"> Verify that the detector wiring is correct and secure. Verify that the wiring between the M2A and the controller is correct and secure. Calibrate the M2A. If the fail condition continues, replace the detector. If the fail condition continues, contact RKI for further instruction. |
| Slow or No Response/ Difficult or Unable to Calibrate | <ul style="list-style-type: none"> Unable to successfully set the fresh air or span (zero for oxygen) reading during calibration. M2A requires frequent calibration. <p><i>Note: See “Calibration Frequency” on page 50 for calibration frequency guidelines.</i></p> | <ul style="list-style-type: none"> The calibration cylinder is low, out-dated, or defective. For non-XP CO, H₂S, or O₂ detectors: The membrane on the detector housing cap is blocked with dirt of some other particulate contamination. For CT-7 Series detectors: The hydrophobic membrane on the plug-in sensor face is blocked with dirt or some other particulate contamination. The detector is malfunctioning. The terminal PCB is malfunctioning. | <ol style="list-style-type: none"> Verify that the calibration cylinder contains an adequate supply of a fresh test sample. For non-XP CO, H₂S, or O₂ detectors: Check the face of the detector housing cap and remove any particulate contamination from the hydrophobic membrane, if necessary. If the membrane appears saturated with contamination or is damaged, replace the membrane as described in “Replacing the Hydrophobic Membrane (Non-XP CO, H₂S, and O₂ Detectors)” on page 59. For CT-7 Series detectors: Check the plug-in sensor face and remove any particulate contamination from the hydrophobic membrane, if necessary. If the membrane appears saturated with contamination or is damaged, replace the membrane as described in “Replacing the Hydrophobic Membrane (CT-7 Series Toxic Detector)” on page 59. If the calibration/response difficulties continue, replace the detector. If the calibration/response difficulties continue, contact RKI for further instruction. |

Calibration Frequency

Some M2As have IR (infrared) type detectors, such as an M2A for CO₂ or an LEL M2A with an IR detector. Most of the M2As do not have an IR detector. For example, an H₂S M2A has an electrochemical detector and some of the combustible M2As use catalytic detectors. The M2As that use IR detectors typically need less frequent calibration as is discussed below. See Table 3, “Infrared (IR) Detectors,” on page 12 to see which M2As are IR versions.

Although there is no particular calibration frequency that is correct for all applications, a calibration frequency of every 3 to 6 months for M2As that do not have an IR detector and every 6 to 12 months for M2As that have an IR detector is adequate for most M2A applications. Unless experience in a particular application dictates otherwise, RKI Instruments, Inc. recommends a calibration frequency of every 3 months for M2As that do not have an IR detector and every 6 months for M2As that have an IR detector.

If an application is not very demanding, for example detection in a clean, temperature controlled environment where the toxic or combustible target gas is not normally present, and calibration adjustments are minimal at calibration, then a calibration frequency of every 6 months for a non-IR M2A or 12 months for an IR M2A is adequate.

If an application is very demanding, for example if a combustible or toxic gas is present often and in significant concentrations or the environment is not well controlled, then more frequent calibration than every 3 months for a non-IR M2A or every 6 months for an IR M2A may be necessary. For combustible gas detection with an M2A that uses a catalytic detector, if potential catalyst poisons are known or likely to be present, more frequent calibration than every 3 months will be necessary.

Calibration, Combustible Gas, CO₂, and Toxic Versions

This section describes how to calibrate the combustible gas, CO₂, and toxic gas versions of the M2A. It includes procedures to prepare for calibration, enter Calibration Mode, adjust the fresh air (zero) setting, adjust the span setting, and return to normal operation. See the next section, “Calibration, Oxygen Version” for instructions to calibrate an oxygen M2A.

NOTE: The detector must be calibrated with a gas concentration between 10% and 100% of the channel’s full scale value (ie. a 0 - 300 ppm CO detector must be calibrated with a CO concentration between 30 and 300 ppm).

WARNING: *The M2A is not an active gas monitoring device during the calibration procedure. The 4-20 mA output signal will “freeze” at 3.5 mA and all relays will remain in their non-alarm state while the M2A is in Calibration Mode. The output signal will not indicate current readings and the relays will not resume operating normally until the M2A is in normal operation again.*

Special Note About Calibrating a ClO₂ Detector

RKI Instruments, Inc. recommends using a ClO₂ generator to set the ClO₂ detector’s response reading. The flow rate on the generator needs to be set to 0.5 LPM and RKI Instruments, Inc. recommends that 0.5 ppm ClO₂ be used. If a ClO₂ generator is used for calibration, the steps related to the use of a calibration gas cylinder in the instructions below can be disregarded.

Non-Intrusive Calibration

If the M2A is installed in a classified area and non-intrusive calibration is required, follow the instructions below, but do not remove the junction box cover. Use the magnetic wand accessory to actuate the magnetic switches instead of pushing the control switch buttons. To actuate a magnetic switch and perform the same operation as pressing a control switch button, touch the magnet in the end of the magnetic wand to the M2A's glass cover directly above the magnetic switch you wish to actuate. Touching the glass and removing the wand is the same as pressing and releasing a button. Touching the glass and keeping the wand in place is the same as pressing and holding a button.

Calibration Gas Response Memory Feature

The M2A has the capability to “remember” the detector's response to the calibration gas after the gas is removed from the detector during the fresh air and span adjustment procedure. This feature enables one person to perform a calibration if the detector is mounted remotely from the M2A. When zero air is applied to the M2A during a fresh air adjustment, the M2A will freeze the display reading at the lowest response and the M2A will continue to display this reading and retain it in its memory until the fresh air adjustment procedure is completed. When calibration gas is applied to the M2A during a span adjustment, the M2A will freeze the display reading at the highest response to the calibration gas. The calibration gas can then be removed and the M2A will continue to display this reading and retain it in its memory until the span adjustment procedure is completed.

Preparing for Calibration

NOTE: The following procedure assumes the use of a calibration kit which includes a calibration gas cylinder, a zero air cylinder, a fixed flow regulator with an on/off knob, a calibration cup for the appropriate sensor, and a short piece of sample tubing to connect the regulator to the calibration cup.

NOTE: While in the calibration program, if there is no switch activity for the calibration time-out period the unit will return to normal operation. See “Viewing & Changing M2A Parameters” on page 42 for instructions to set the calibration time-out.

NOTE: The following procedure assumes that the target gas is present in a high enough concentration to affect the fresh air (zero) reading. If a fresh air environment can be verified, applying zero air to the detector is not necessary when setting the zero (span for oxygen) reading.

CAUTION: *If calibrating a CT-7 Series M2A, allow the instrument to warm up for 15 minutes before performing a calibration.*

WARNING: ***RKI Instruments, Inc. recommends that you dedicate a regulator for use with chlorine (Cl₂) gas and that you do not use that dedicated regulator for any other gases, particularly hydrogen sulfide (H₂S).***

1. Connect the calibration kit sample tubing to the calibration cup hose barb.
2. Screw the calibration cup onto the detector.

NOTE: For an ESM-01 detector, you must unscrew the removable splashguard from the detector housing cap so you can push the appropriate calibration cup onto the ESM-01 sensor. Make sure to use the correct calibration cup for the sensor being used. There is a Cl₂ type calibration cup for a Cl₂ sensor, an NH₃ type calibration cup for an NH₃ sensor, and a general type (usually labeled SO₂) calibration cup for all other ESM-01 sensors.

3. Connect the fixed flow regulator to the calibration cup using the sample tubing.

NOTE: When calibrating an NH₃ ESM-01, the 0.25 LPM flowrate regulator must be used. All other M2As require a 0.5 LPM flowrate regulator.

Adjusting the Fresh Air Reading

1. While in normal operation, press and hold the UP/YES button for 5 seconds to enter Calibration Mode. Release the button when the following screen appears.

Calib?
YES/NO

2. If you want to continue with calibration, press and release the UP/YES button. The display will indicate the target gas and **CAL Mode** for a few seconds before showing **FreshAir Adjust?**.

If you want to exit Calibration Mode, press and release the DOWN/NO button. The M2A will indicate **Leaving CAL Mode** and the M2A will return to normal operation.

3. To continue with adjusting the fresh air reading, press and release the UP/YES button. **ENTER** will alternate with **FreshAir** on the top display line and the current gas reading will be on the bottom display line.

To skip adjusting the fresh air reading, press and release the DOWN/NO button. The display will indicate **SPAN w/Cal Gas?**. Skip to the next section, "Adjusting the Span Setting".

4. Screw the zero air cylinder into the fixed flow regulator.
5. Turn the regulator knob counterclockwise to open the regulator.
6. Allow zero air to flow for two minutes. If there was gas present causing a reading on the M2A, the reading should decrease and stabilize after two minutes.
7. Turn the regulator knob clockwise to close the regulator.
8. Unscrew the zero air cylinder from the fixed flow regulator leaving the calibration cup on the detector. The M2A will continue to display the minimum gas response on the display and retain the response level in its memory.
9. Press and release the ENTER button. The M2A will perform a fresh air adjustment and the display will indicate **SPAN w/Cal Gas?**.

NOTE: If the fresh air adjustment fails, see "Troubleshooting" on page 48 for recommended actions.

Adjusting the Span Setting

1. If you want to continue with adjusting the span setting, press and release the UP/YES button. **APPLY** will alternate with **SPAN Gas** on the top display line and the current gas reading will be on the bottom display line.

If you want to skip adjusting the span reading, press and release the DOWN/NO button. The display will indicate **Leaving Cal Mode** and the M2A will return to normal operation.

2. For combustible gas and CO₂ detectors:
 - a. Screw the calibration gas cylinder onto the fixed flow regulator.
 - b. Turn the regulator knob counterclockwise to open the regulator (or start the flow of gas from a generator).
 - c. Continue to Step 4.
3. For toxic sensors:
 - a. It is important to vent the regulator while installing it onto the cylinder. Venting the regulator during installation helps prevent air from getting into the cylinder and degrading the gas. Open the regulator by turning the knob counterclockwise.
 - a. Install the regulator onto the cylinder.
 - b. Continue to Step 4.
4. Allow calibration gas to flow for two minutes. The gas reading should be stable after two minutes.
5. Turn the regulator knob clockwise to close it (or stop the flow of gas from a generator).
6. Unscrew the calibration gas cylinder from the fixed flow regulator and unscrew the calibration cup from the detector. For an ESM-01 detector, pull the calibration cup off of the ESM-01 sensor and screw the splashguard back onto the detector housing cap. The M2A will continue to display the maximum gas response on the display and retain the response level in its memory.
7. **Adjust the gas reading up or down to match the calibration gas cylinder concentration by using the UP/YES and DOWN/NO buttons, then press and release the ENTER button.**

NOTE: The detector must be calibrated with a gas concentration between 10% and 100% of the channel's full scale value (ie. a 0 - 300 ppm CO detector must be calibrated with a CO concentration between 30 and 300 ppm).

8. The M2A will perform a span operation. The display will indicate **SPAN Gas PASS** for a few seconds, then indicate **SPAN Gas SAVED** before indicating **Leaving CAL Mode** for a few seconds.

NOTE: If the span adjustment fails, see "Troubleshooting" on page 48 for recommended actions.

9. The display will now alternate between the normal operation screen and the message **REMOVE CAL GAS** for 1 minute. If the calibration gas has not been removed from the detector, remove it now to avoid unwanted alarms.

During this 1 minute period, the signal output will remain fixed at 3.5 mA and the relays will remain in their non-alarm state to avoid unwanted alarms while the calibration gas clears from the detector. At the end of the 1 minute period, the **REMOVE CAL GAS** message will stop appearing and the M2A will return to normal operation.

10. Store the components of the calibration kit in a safe place.

Calibration, Oxygen Version

This section describes how to calibrate the oxygen version of the M2A. It includes procedures to prepare for calibration, enter Calibration Mode, set the fresh air (span) reading, set the zero reading, and return to normal operation.

NOTE: An O₂ detector must be calibrated with 0 - 18% O₂.

WARNING: *The M2A is not an active gas monitoring device during the calibration procedure. The 4-20 mA output signal will “freeze” at 17.4 mA and all relays will remain in their non-alarm state while the M2A is in Calibration Mode. The output signal will not indicate current readings and the relays will not resume operating normally until the M2A is in normal operation again.*

Preparing for Calibration

NOTE: The following procedure assumes the use of a calibration kit which includes a zero air (20.9% oxygen) calibration cylinder to set the fresh air reading, a 100% nitrogen (0% oxygen) calibration gas cylinder to set the zero reading, a fixed flow regulator with an on/off knob, a calibration cup, and a short piece of sample tubing to connect the regulator to the calibration cup. A cylinder with up to an 18% oxygen concentration may be used instead of a 100% nitrogen cylinder to set the zero reading.

NOTE: While in calibration mode, if there is no switch activity for the calibration time-out period the unit will return to normal operation. See “Viewing & Changing M2A Parameters” on page 42 for instructions to set the calibration time-out.

NOTE: The following procedure assumes that the oxygen concentration in the calibration area is not normal, 20.9%, but is oxygen deficient. If a fresh air environment can be verified, applying zero air to the detector is not necessary when adjusting the fresh air (span) setting.

1. Connect the calibration kit sample tubing to the calibration cup hose barb.
2. Screw the calibration cup onto the detector.
3. Connect the fixed flow regulator to the calibration cup using the sample tubing.

Non-Intrusive Calibration

If the M2A is installed in a classified area and non-intrusive calibration is required, follow the instructions below, but do not remove the junction box cover. Use the magnetic wand accessory to actuate the magnetic switches instead of pushing the control switch buttons. To actuate a magnetic switch and perform the same operation as pressing a control switch button, touch the magnet in the end of the magnetic wand to the M2A’s glass cover directly above the magnetic switch you wish to actuate. Touching the glass and removing the wand is the same as pressing and releasing a button. Touching the glass and keeping the wand in place is the same as pressing and holding a button.

Calibration Gas Response Memory Feature

The M2A has the capability to “remember” the detector’s response to the calibration gas after the gas is removed from the detector during the fresh air or zero adjustment procedure. This feature enables one person to perform a calibration if the detector is mounted remotely from the M2A. When zero air is applied to the M2A during a fresh

air adjustment, the M2A will freeze the display reading at the highest response and the M2A will continue to display this reading and retain it in its memory until the fresh air adjustment procedure is completed. When calibration gas is applied to the M2A during a zero adjustment, the M2A will freeze the display reading at the lowest response to the calibration gas. The calibration gas can then be removed and the M2A will continue to display this reading and retain it in its memory until the zero adjustment procedure is completed.

Adjusting the Fresh Air Setting

1. While in normal operation, press and hold the UP/YES button for 5 seconds to enter Calibration Mode. Release the button when the following screen appears.

| |
|------------------|
| Calib? YES/NO |
|------------------|

2. If you want to continue with calibration, press and release the UP/YES button to continue. The display will indicate **OXYGEN CAL Mode** for a few seconds before showing **FreshAir Adjust?**.

If you want to exit Calibration Mode, press and release the DOWN/NO button. The M2A will indicate **Leaving CAL Mode** and the M2A will return to normal operation.

3. To continue with adjusting the fresh air (span) reading, press and release the UP/YES button. **ENTER** will alternate with **FreshAir** on the top display line and the current oxygen reading will be on the bottom display line.

To skip adjusting the fresh air reading, press and release the DOWN/NO button. The display will indicate **ZERO w/Cal Gas?**. Skip to the next section, "Adjusting the Zero Setting".

4. Screw the zero air cylinder into the fixed flow regulator.
5. Turn the regulator knob counterclockwise to open the regulator.
6. Allow zero air to flow for 2 minutes. If the oxygen concentration in the area is less than 20.9, the reading should stabilize after 2 minutes.
7. Turn the regulator knob clockwise to close the regulator.
8. Unscrew the zero air cylinder from the fixed flow regulator leaving the calibration cup on the detector. The M2A will continue to display the maximum gas response on the display and retain the response level in its memory.
9. Press and release the ENTER button. The M2A will perform a fresh air adjustment and the display will indicate **ZERO w/Cal Gas?**.

NOTE: If the fresh air adjustment fails, see "Troubleshooting" on page 48 for recommended actions.

Adjusting the Zero Setting

1. If you want to continue with adjusting the zero setting, press and release the UP/YES button. **APPLY** will alternate with **ZERO Gas** on the top display line and the current oxygen reading will be on the bottom display line.

If you want to skip adjusting the zero reading, press and release the DOWN/NO button. The display will indicate **Leaving Cal Mode** and the M2A will return to normal operation.

2. Screw the 100% nitrogen gas cylinder into the fixed flow regulator.
3. Turn the regulator knob counterclockwise to open the regulator.
4. Allow gas to flow for 2 minutes. The gas reading should be stable after 2 minutes.
5. Turn the regulator knob clockwise to close the regulator.
6. Unscrew the nitrogen cylinder from the fixed flow regulator and unscrew the calibration cup from the detector. The M2A will continue to display the minimum gas response on the display and retain the response

level in its memory.

7. **Adjust the oxygen reading up or down to match the 100% nitrogen cylinder oxygen concentration of 0 by using the UP/YES and DOWN/NO buttons.**

NOTE: An O₂ detector must be calibrated with 0 - 18% O₂.

8. Press and release the ENTER button. The M2A will perform a zero operation. The display will indicate **ZERO Gas PASS** for a few seconds, then indicate **ZERO Gas SAVED** before indicating **Leaving CAL Mode** for a few seconds.

NOTE: If the zero adjustment fails, see “Troubleshooting” on page 48 for recommended actions.

9. The display will now alternate between the normal operation screen and the message **REMOVE CAL GAS** for 1 minute. If the calibration gas has not been removed from the detector remove it now to avoid unwanted alarms.

During this 1 minute period, the signal output will remain fixed at 17.4 mA and the relays will remain in their non-alarm state to avoid unwanted alarms while the calibration gas clears from the detector. At the end of the 1 minute period, the **REMOVE CAL GAS** message will stop appearing and the M2A will return to normal operation.

10. Store the components of the calibration kit in a safe place.

Replacing Components of the M2A

Replacing the Gas Detector

NOTE: For M2A versions that do not have a replaceable plug-in sensor, or if you determine that it is necessary to replace the entire detector, use the procedure in this section to change the entire detector. For M2A versions that include a replaceable plug-in sensor, see the appropriate instructions in the sections that follow this one to replace the plug-in sensor.

1. Turn off or disconnect power to the M2A.
2. Remove the junction box cover.
3. Grasp the control PCB by its edges.
4. Gently pull until the control PCB is pulled away from the banana jacks. Take care not to pull too hard and damage the cable which connects the control and terminal PCBs.
5. Let the control PCB hang by the cable. The terminal strips are now visible on the terminal PCB. The control PCB may be left hanging while wiring is done. If desired, the control PCB may be disconnected from the cable and set aside while wiring.
6. Remove the detector terminal strip from its socket.
7. Disconnect the detector leads from the detector terminal strip. Note the position of the color-coded leads as you remove them.
8. Unscrew the detector from the junction box.
9. Guide the replacement detector leads through the bottom conduit port of the junction box, then screw the mounting threads of the detector into the conduit port. If necessary for environmental conditions, apply thread sealant or Teflon tape to the hub and/or detector threads to seal them.

10. Connect the detector leads to the detector terminal strip as follows:
 - Catalytic Combustible Gas Detector, IR Combustible Gas Detector, and IR CO₂ Detector
Red wire to terminal labeled LEL RED, white to terminal labeled LEL WHT, green wire to terminal labeled LEL GRN, black wire to terminal labeled LEL BLK.
 - CO or H₂S Gas Detector
Red wire to terminal labeled TOXIC +, black wire to terminal labeled TOXIC -.
 - ESM-01 Toxic Gas Detector or CT-7 Series Toxic Gas Detector
Color coded wire to terminal labeled TOXIC +, black wire to terminal labeled TOXIC -. See Figure 28 on page 31 and Figure 29 on page 32 for the wire color coding.
 - Oxygen Gas Detector
White wire to terminal labeled OXY +, green wire to terminal labeled OXY -.
11. Re-install the detector terminal strip into its socket.
12. Re-install the control PCB (and ribbon cable if necessary). Be sure the ribbon cable is routed down below the control PCB so it will not be damaged by the cover when it is screwed back on.
13. Secure the junction box cover to the junction box.
14. Turn on or reconnect power to the M2A.

NOTE: Allow the replacement detector to warm up for 15 minutes before you continue with the next step.

15. Calibrate the replacement detector as described in “Calibration, Combustible Gas, CO₂, and Toxic Versions” on page 50 or “Calibration, Oxygen Version” on page 54.

Replacing the CO, H₂S, or CT-7 Series Plug-in Sensor

NOTE: This procedure is applicable for: the CSA type, explosion proof CO and H₂S detectors, the non-explosion proof CO and H₂S detectors, and the CT-7 Series detectors.

1. Turn off or disconnect power to the M2A.
2. Unscrew the detector cap from the housing body. Make sure not to lose the cap gasket. See Figure 5, Figure 6, and Figure 8 for illustrations of the detectors.
3. Unplug and remove the sensor.
4. If you are replacing a CO sensor, remove the rubber boot and charcoal filter from the old sensor.

NOTE: RKI instruments recommends replacing the charcoal disk filter whenever a CO sensor is replaced.

If you are replacing the 65-2428 explosion-proof H₂S detector’s sensor, remove the rubber boot and spacer from the old sensor.

5. Remove the replacement sensor from its packaging and remove the wire jumper. This wire jumper is installed on the sensor pins for shipment or storage but must be removed for the sensor to operate properly when installed in a detector.

WARNING: *The sensor will not operate properly if the wire jumper is not removed.*

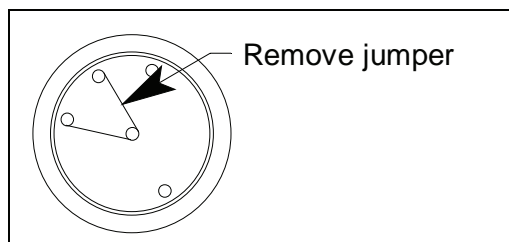

Figure 31: Plug-In Sensor Jumper Removal

6. If you are replacing a CO sensor, install the rubber boot and charcoal filter onto the new sensor's face.
If you are replacing the 65-2428 explosion-proof H₂S detector's sensor, install the rubber boot and spacer on the new sensor's face.
7. Carefully match the replacement sensor's male pins with the 4-socket pattern in the top section and plug it in.
8. Make sure the cap gasket is in place and screw the detector cap back onto the housing body.
9. Turn on or reconnect power to the M2A.

CAUTION: *Allow the replacement sensor to warm up for 15 minutes before you continue with the next step.*

10. Calibrate the detector as described in "Calibration, Combustible Gas, CO₂, and Toxic Versions" on page 50.

Replacing the CO Sensor Charcoal Filter

The charcoal filter is used to scrub out interfering gases from the environment being monitored, such as H₂S and certain hydrocarbons. If you are experiencing unexplained upscale readings on a CO M2A, the charcoal filter may be saturated and no longer scrubbing out interfering gases and it may be necessary to change the charcoal filter.

1. Turn off or disconnect power to the M2A.
2. Unscrew the detector housing cap from the housing body. Make sure not to lose the cap gasket. See Figure 6 for an illustration of the CO detector.
3. Remove the rubber retaining boot with the charcoal filter disk from the sensor.
4. Replace the charcoal filter disk in the rubber retaining boot and install the boot onto the sensor.
5. Make sure that the cap gasket is in place and screw the detector cap back onto the housing body.
6. Turn on or reconnect power to the M2A.

Replacing an Oxygen Plug-in Sensor

NOTE: This procedure is applicable for both the CSA type, explosion proof oxygen detector (65-2514RK) and non-explosion proof, replaceable sensor oxygen detector (65-2494RK).

1. Turn off or disconnect power to the M2A.
2. Unscrew the detector cap from the detector housing body. Take care not to lose the cap gasket. See Figure 4 for an illustration of the oxygen detectors.
3. Unplug and remove the sensor.

4. Carefully match the replacement sensor's male pins with the 2-socket pattern in the top section and plug it in.
5. Make sure the cap gasket is in place and screw the detector cap back on to the detector housing.
6. Turn on or reconnect power to the M2A.

NOTE: Allow the replacement sensor to warm up for 15 minutes before you continue with the next step.

7. Calibrate the detector as described in "Calibration, Combustible Gas, CO₂, and Toxic Versions" on page 50.

Replacing an ESM-01 Plug-in Sensor

1. Turn off or disconnect power to the M2A.
2. Unscrew the detector cap from the detector housing body. Take care not to lose the cap gasket. If the splashguard begins to unscrew from the detector cap, make sure to remove the detector cap also. See Figure 7 for an illustration of the ESM-01 detector.
3. Unplug and remove the sensor.
4. Remove the black plug from the top of the replacement sensor.
5. Carefully match the replacement sensor's plug with the socket in the housing body and plug it in.

WARNING: *The ESM-01 detectors cannot be changed from one type to another. Replace the plug-in sensor only with the same type of ESM-01 sensor.*

6. Make sure the cap gasket is in place and screw the detector cap back onto the housing body. If the splash guard was unscrewed from the detector cap, screw it back onto the detector cap.
7. Turn on or reconnect power to the M2A.

NOTE: Allow the replacement sensor to warm up for 15 minutes before you continue with the next step.

8. Calibrate the detector as described in "Calibration, Combustible Gas, CO₂, and Toxic Versions" on page 50.

Replacing the Hydrophobic Membrane (Non-XP CO, H₂S, and O₂ Detectors)

1. Turn off or disconnect power to the M2A.
2. Unscrew the detector housing cap from the detector housing body.
3. Gently pry up the edge of the white hydrophobic membrane with a small flat blade screwdriver or a similar tool.
4. Peel off the hydrophobic membrane. It may be necessary to clean off the detector housing cap face to remove any residue left from the adhesive backed membrane.
5. Install the new membrane in the recess on the face of the detector housing cap.
6. Make sure the cap gasket is in place and screw the detector housing cap back onto the detector housing body.
7. Turn on or reconnect power to the M2A.

Replacing the Hydrophobic Membrane (CT-7 Series Toxic Detector)

1. Turn off or disconnect power to the M2A.
2. Unscrew the detector housing cap from the detector housing body.
3. Unplug the plug-in sensor from the four-socket pattern in the detector housing body.
4. Gently pry up the edge of the white hydrophobic membrane from the sensor face with a small flat blade screwdriver or a similar tool.

5. Peel off the hydrophobic membrane. It may be necessary to clean off the sensor face to remove any residue left from the adhesive backed membrane.
6. Install the new membrane on the face of the plug-in sensor.
7. Plug the sensor back into the four-socket pattern in the detector housing body.
8. Make sure the cap gasket is in place and screw the detector housing cap back onto the detector housing body.
9. Turn on or reconnect power to the M2A.

Chapter 8: RS-485 Modbus Output

Overview

This chapter describes the M2A's RS-485 Modbus output and how to configure the M2A to make use of it. It also discusses how to wire the M2A into a Modbus system.

The M2A provides an RS-485 serial communications interface. It is a Modbus Slave Device, supporting 2-wire RS-485 Modbus RTU serial communications.

Wiring the M2A in a Modbus System

The M2A is a 2-wire Modbus RTU device. When wiring the M2A into a Modbus system, adhere to standard Modbus wiring practices per the Modbus Over Serial Line Specification and Implementation Guide V1.0 or later. This document can be found online at www.modbus.org/specs.php.

The Modbus protocol supports a maximum of 247 unique slave addresses (1-247). The M2A's line driver provides for up to 128 M2As to be connected together without the need for a repeater. Figure 34 & Figure 35 below illustrate typical M2A wiring configurations. If more than 128 M2As need to be connected together, RS-485 repeater(s) should be used such that no more than 128 M2As reside on any given network segment.

CAUTION: *The network segment can only support 128 units if RKI M2As are being used. The use of any other instruments will lower the number of units that may reside on any given network segment.*

The MODBUS terminal strip is located on the terminal PCB (see Figure 9). The following signals are available at the Modbus terminal strip:

Table 15: Modbus Terminal Strip Signals

| Modbus Terminal Label (RS-485 Name) | Modbus Signal Name |
|--|--------------------|
| A | D0 |
| B | D1 |
| C | Common |

Ground Jumper

The M2A includes a 2-pin ground header (see Figure 10) that is used when the M2A is used in a Modbus system. Every M2A is supplied with a ground jumper (a jumper block) installed onto this header. If the M2A isn't wired into a Modbus system or if it is wired into one as shown in Figure 33, the ground jumper should be installed. If the M2A is wired in a Modbus system as shown in Figure 32, the ground jumper should be removed.

Recommended Modbus Wiring

The recommended Modbus wiring for the M2A is illustrated in Figure 32 below. In this configuration, 5 wires are used for wiring the M2A into a Modbus system. Figure 32 also illustrates typical alarm device wiring. The ground jumper must be removed in this wiring configuration.

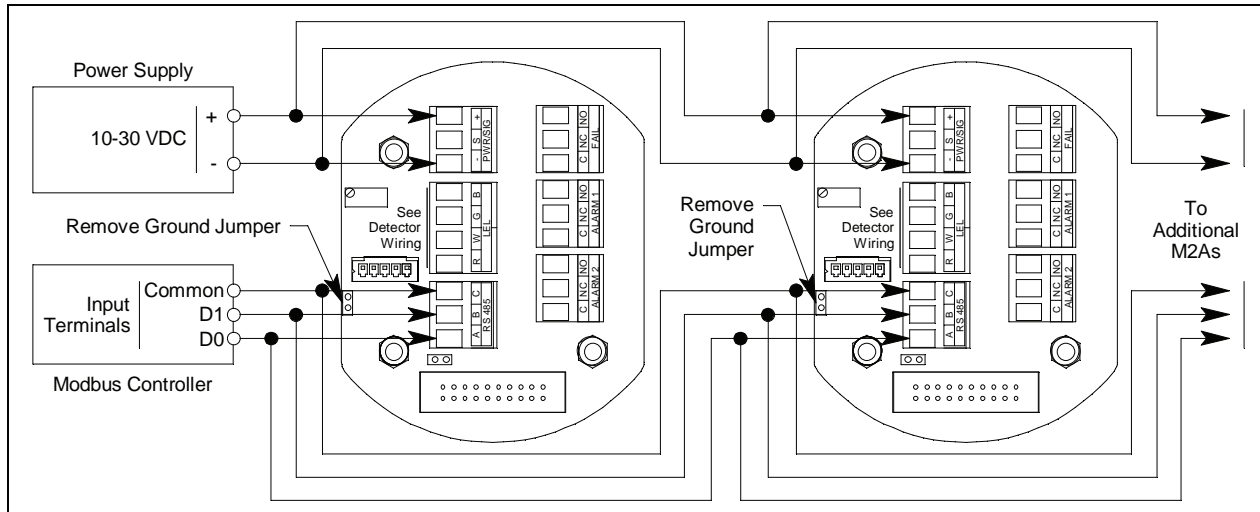

Figure 32: Recommended Modbus Wiring

Adding an M2A to an Existing M2 Modbus Installation with Recommended Wiring

An M2A can be wired into an existing M2 Modbus system. The shape of the terminal PCB will be different but the wiring connections are identical and the ground jumper on the M2A must still be removed.

Alternate Modbus Wiring For Existing Installations

Although the wiring shown in Figure 32 is recommended, it is possible to wire the M2A into a Modbus system with only 4 wires in situations where a pre-existing system is being replaced and wiring is already in place. This should only be done if wiring for a system that is being replaced is already installed and it is not practical to run another wire. See Figure 33 below for this wiring configuration. In this configuration, the wire between the “C” terminal on the M2A and the Common terminal on the Modbus controller is omitted. Instead, the Common terminal on the Modbus controller is connected to the “-” of the 24 VDC power supply. The ground jumper must be installed in this wiring configuration.

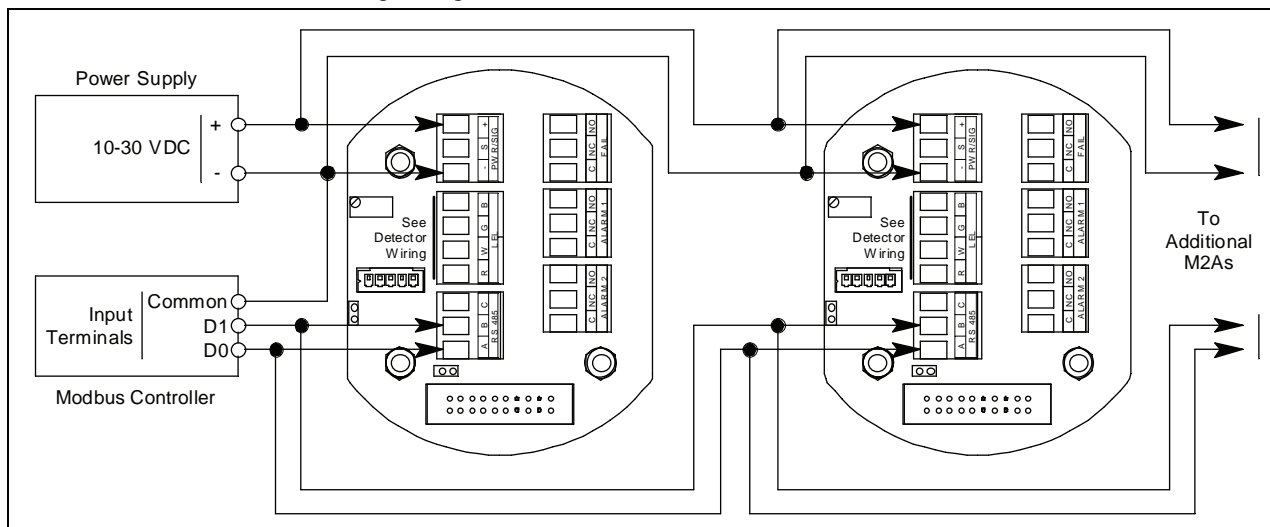

Figure 33: Alternate Modbus Wiring

Adding an M2A to an Existing M2 Modbus Installation with Alternate Wiring

An M2A can be wired into an existing M2 Modbus system. The shape of the terminal PCB will be different but the wiring connections are identical and the ground jumper on the M2A must still remain installed.

Termination Jumper

The M2A includes a 2-pin termination header (see Figure 10) that is used when the M2A is used in a Modbus system. Every M2A is supplied with a termination jumper (a jumper block) installed onto this header. If the M2A is not used in a Modbus system, this jumper has no function. When the M2A is installed in a Modbus system, this jumper must be installed in an M2A that is at the end of a Modbus line. Any M2A in a Modbus system that is not at the end of a line must have the termination jumper removed (see Figure 34 & Figure 35 below).

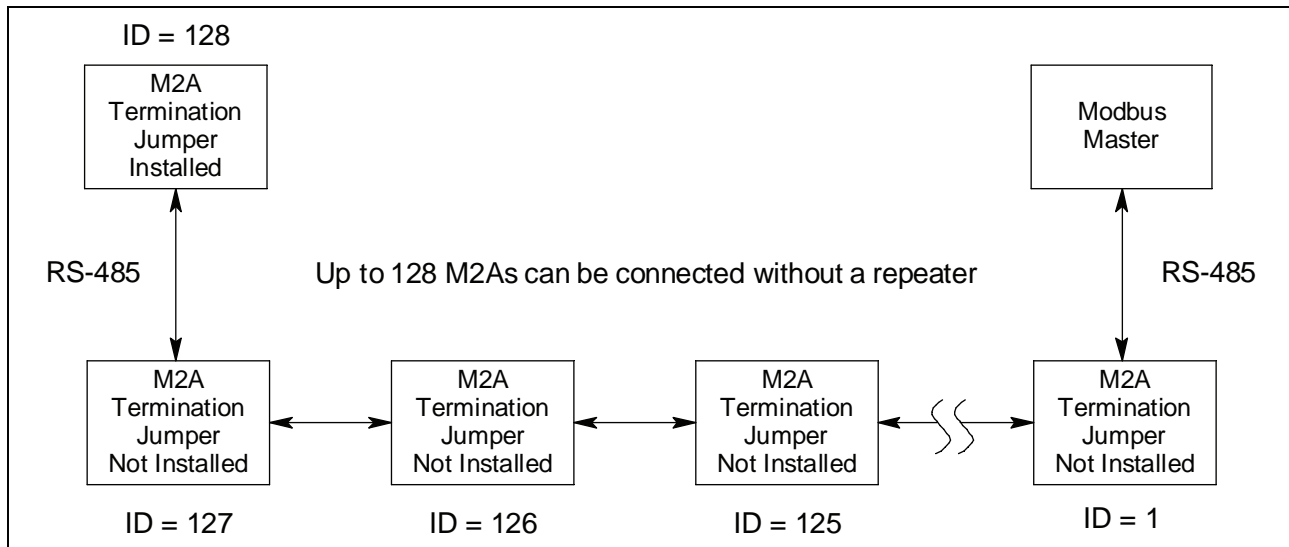

Figure 34: Multiple M2As in a Daisy Chain Configuration

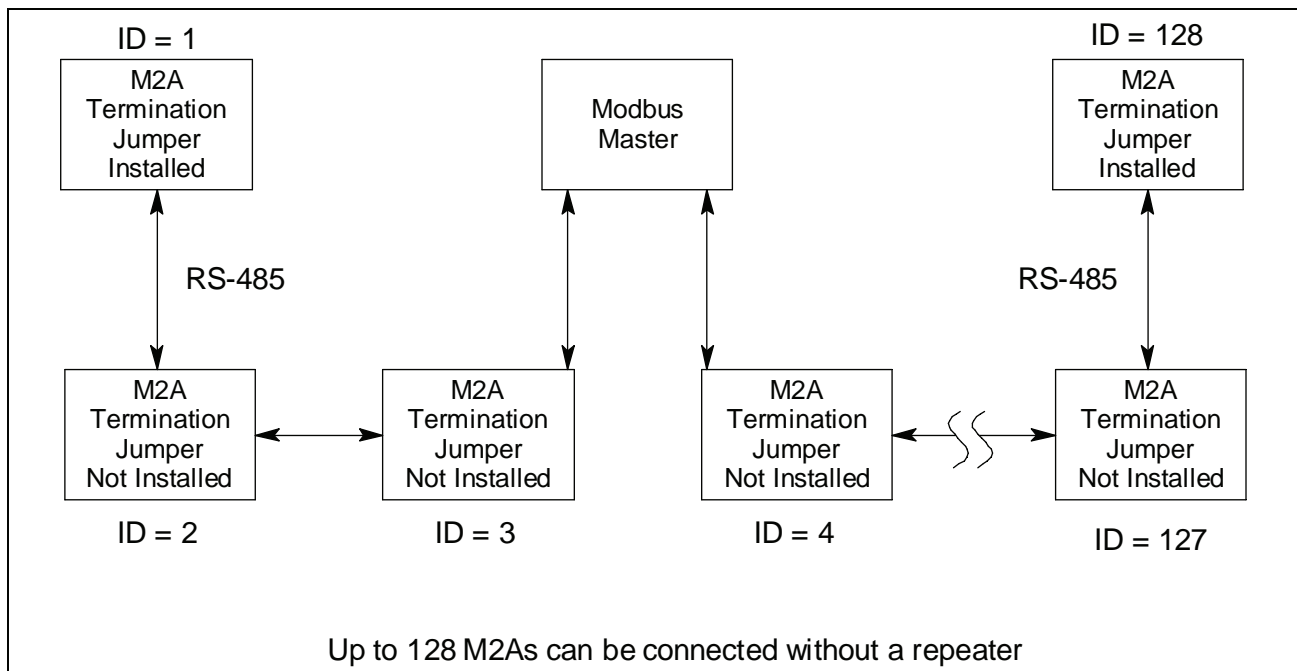

Figure 35: Multiple M2As in a Two Branch Configuration

Using the M2A in a 4-wire Modbus System

Although the M2A is a 2-wire Modbus RTU device, it can be used with a 4-wire Modbus controller if the system wiring is modified as follows:

- Connect the controller's TxD0 and RxD0 wires together and use this connection as the 2-wire Modbus D0 signal.
- Connect the controller's TxD1 and RxD1 wires together and use this connection as the 2-wire Modbus D1 signal.
- Connect these D0 and D1 signals and the common wire from the controller to the 2-wire Modbus Network of M2As.

Modbus Mode

Modbus Mode allows you to configure various parameters relating to the Modbus setup of the M2A. Modbus Mode includes a 5-minute time-out feature. If you do not press a control button for 5 minutes, the M2A automatically returns to normal operation.

NOTE: If the M2A returns to normal operation because of a time-out, it enters a warm-up period just as it does when it is first turned on.

1. While in normal operation, simultaneously press and hold the DOWN/NO and ENTER buttons for 5 seconds to enter Modbus Mode. Release the buttons when the following screen appears.

Set Up
Modbus?

2. To exit Modbus Mode, press and release the DOWN/NO button. The M2A will return to normal operation. To continue in Modbus Mode, press and release the UP/YES button. The current ENABLED/DISABLED setting will appear.
3. If you want to change the currently displayed parameter, use the UP/YES and DOWN/NO buttons to adjust it to the desired setting, then press ENTER to continue to the next parameter.

If the currently displayed parameter setting is OK, press the ENTER button to proceed to the next parameter.

Table 16 lists the M2A Modbus Mode parameters you can set. Table 16 also lists the factory set value for each parameter.

Table 16: Modbus Configuration Parameters

| Modbus Mode Parameter | Available Settings & Description |
|-----------------------|--|
| Enabled/Disabled | Can be set to ENABLED or DISABLED (factory setting). Enables or disables the Modbus output. |
| Slave ID | The Slave ID can be set to values from 1 (factory setting) to 247. The M2A will only receive messages from the Master which are addressed to this Slave ID (except for broadcast messages which are received by all slaves). |
| Baud Rate | Can be set to 1200, 2400, 4800, 9600 (factory setting), 14440, & 19200. |
| Parity | EVEN (factory setting), ODD, NONE |
| Response Delay | The response delay can be set from 0 (factory setting) to 20 mS. This is an optional additional delay inserted by the M2A prior to returning a response message to the Master. It may be helpful in some installations where the Master's preparedness to receive responses might be delayed. |

4. When you have scrolled through all the adjustable parameters, **SAVE IT? YES/NO** appears on the display.
5. If you do not wish to save the adjustments, press and release the **DOWN/NO** button. The **DO OVER? YES/NO** message will display. Press and release the **DOWN/NO** button. The **ABORT? YES/NO** message will display. Press the **UP/YES** button to return to normal operation.

If you wish to change some of the adjustments made, press and release the **DOWN/NO** button. The **DO OVER? YES/NO** message will display. Press and release the **UP/YES** button. The **Re-do MB Setup** message will display and the M2A will return to the first adjustable parameter. Go back to step 3 and continue.

If you want to save the adjustments made, press and release the **UP/YES** button. **Modbus Saved** is indicated on the display for a few seconds and the M2A returns to normal operation.

NOTE: All M2As on a Modbus network must be configured with the same baud rate and parity, and each M2A must have a unique slave ID. For an M2A to participate on a network, the **ENABLED/DISABLED** setting must be set to **ENABLE**.

Supported Modbus Functions

The M2A supports Function Code 03: Read Holding Registers and Function Code 16: Write Registers.

Function Code 03: Read Holding Registers

There are a total of 40 registers available to be read via this Function Code.

Registers 1 - 2

The format (bit & field assignments) for registers 1 - 2 is shown below in Table 17 - Table 18.

Table 17: Register 1, Numerical Reading with Sign & Decimal Point Bit & Field Assignments

| Bit(s) | Value & Field |
|---------|--|
| [15] | <u>Sign of Reading</u> 0 = Positive 1 = Negative |
| [14:13] | <u>Format of Reading</u> 0 = XXX (no decimal point) 1 = XX.X 2 = X.XX 3 = .XXX |
| [12:0] | Numerical value of display reading (8000 max) |

Table 18: Register 2, Operating State, Alarms & Relays Bit & Field Assignments

| Bit(s) | Value |
|---------|---|
| [15:12] | <u>Operating State</u> 0 = Undefined 1 = Initialization 2 = Normal 3 = Warm-up 4 = Fail 5 = Calibration 6 = Post-Calibration 7 = Low Power 8 = Setup |
| [11] | <u>Gas Type Change</u> 0=Not Changed 1=Changed |
| [10] | <u>Configuration Change</u> 0=Not Changed 1=Changed |
| [9] | <u>Calibration Activity Flag</u> 0=No Calibration Activity 1=Calibration Activity Has Occurred |
| [8] | <u>Fail Status</u> 0 = Fail Not Asserted 1 = Fail Asserted |

Table 18: Register 2, Operating State, Alarms & Relays Bit & Field Assignments

| Bit(s) | Value |
|---------------|--|
| [7:6] | <u>Alarm 2 Status</u> 0 = No Alarm 1 = Unacknowledged Alarm 2 = Acknowledged Alarm 3 = Unused Code |
| [5:4] | <u>Alarm 1 Status</u> 0 = No Alarm 1 = Unacknowledged Alarm 2 = Acknowledged Alarm 3 = Unused Code |
| [3] | <u>Overscale Status</u> 0 = Not Overscale 1 = Overscale |
| [2] | <u>Fail Relay Status</u> 0 = Not Energized 1 = Energized |
| [1] | <u>Alarm 2 Relay Status</u> 0 = Not Energized 1 = Energized |
| [0] | <u>Alarm 1 Relay Status</u> 0 = Not Energized 1 = Energized |

Register 3

Register 3 is the supply voltage (0.1 volt per count).

Registers 4 - 11

The 16 bytes in these registers contain the same ASCII text information that is displayed on the M2A's OLED (not NULL Terminated).

Register 12

Register 12 is the range (full scale readout).

Register 13

Register 13 is the alarm 1 set point.

The decimal point location is the same as specified in Register 1.

Register 14

Register 14 is the alarm 2 set point.

The decimal point location is the same as specified in Register 1.

Registers 15 - 19

Registers 15 - 19 are the Gas Name ASCII String (NULL Terminated).

Registers 20 - 22

Registers 20 - 22 are the Gas Units String (NULL Terminated).

Register 23

Register 23 is the alarm 1 trigger.

0=Decreasing

1=Increasing

Register 24

Register 24 is the alarm 1 normal relay state.

0=Normally De-Energized

1=Normally Energized

Register 25

Register 25 is the alarm 1 relay reset.

0=Latching

1=Self-Resetting

Register 26

Register 26 is the alarm 1 ON delay.

Integer values are in seconds.

Register 27

Register 27 is the alarm 1 OFF delay.

Integer values are in seconds.

Register 28

Register 28 is the alarm 2 trigger.

0=Decreasing

1=Increasing

Register 29

Register 29 is the alarm 2 normal relay state.

0=Normally De-Energized

1=Normally Energized

Register 30

Register 30 is the alarm 2 relay reset.

0=Latching

1=Self-Resetting

Register 31

Register 31 is the alarm 2 ON delay.

Integer values are in seconds.

Register 32

Register 32 is the alarm 2 OFF delay.

Integer values are in seconds.

Register 33

Register 33 is zero suppression.

Toxics and LEL: 0%-6% of full scale

Oxygen: 0%-0.7% Oxygen

The decimal point location is the same as specified in Register 1.

Register 34

Register 34 is noise filter.
Integer values in seconds.
0-60 in 5 second increments.

Register 35

Register 35 is calibration timeout in minutes (5, 10, 15, 20, 25, or 30).

Register 36

Register 36 is calibration month (upper byte) and day (lower byte).
This is zero based (e.g. January=0 and the 1st=0).

Register 37

Register 37 is the calibration year.

Register 38

Register 38 is the calibration outcome.
Upper=Gas Operation
Lower=Air Operation

Calibration Outcome Codes:

- 1=Sensor Missing
- 2=Sensor Too Weak
- 3=Signal Too Strong
- 4=Not Enough Span
- 5=Negative Reading
- 6=Span Gas Value Is Not OK
- 7=Calculated Zero Is Too Low
- 8=Calculated Zero Is Too High
- 9=Zero Failure
- 10=Span Failure
- 11=Calibration Is Overscale
- 12=LEL Sensor Offset Is Too High
- 13=LEL Null Operation Failed
- 14=Operation Not Performed

Register 39

Register 39 is the auto-zero disable.
0=AutoZero Enabled
1=AutoZero Disabled

Register 40

Register 40 is the remote configuration register access level
0=None
1=Alarm Reset

Function Code 16: Write Registers

There are 21 registers in Function Code 16 that can be used to write to the M2A. This section only describes Register 16 because it can be used to reset an alarm condition. For a complete description of Function Code 16, see “Appendix C: Function Code 16 Registers” on page 79.

Register 16

Register 16 performs the same function as the ENTER button on the M2A. It is useful for remotely silencing alarms. With the M2A in an alarm condition, bit [0] can be used to silence it.

NOTE: Register 40 in Function Code 03, the remote configuration register, must be set to 1 in order for Register 16 to work.

Table 19: Register 16, Button Function

| Bit | Value & Field |
|-----|--|
| [0] | ENTER (used for “Alarm Reset”) 0=Not Pressed 1=Pressed |

Chapter 9: Parts List

Table 20 lists replacement parts and accessories for the M2A Transmitter.

Table 20: Parts List

| Part Number | Description |
|---------------|--|
| 06-1248RK | Calibration kit sample tubing (3/16 in. x 5/16 in.; specify length when ordering) |
| 07-0033RK | Cap gasket, for CSA type CO and H ₂ S detector |
| 07-0039RK | Cap gasket, for non-XP CO/H ₂ S and CT-7 Series detectors |
| 07-0125RK | Cap gasket, for ESM-01 detector |
| 07-0203RK | Rubber retaining boot for CO detectors' charcoal filter and for 65-2428 H ₂ S detector's spacer |
| 14-2101RK | Spacer for 65-2428 H ₂ S detector |
| 18-0431-01-01 | Junction box with foam pad, label, and conduit plug |
| 33-0157RK | Hydrophobic membrane for non-XP CO, H ₂ S, O ₂ , and CT-7 Series detectors |
| 33-7101RK | Charcoal filter disk |
| 45-6132RK | Termination and ground jumper |
| 61-0140RK | LEL detector, catalytic type, UL version |
| 61-0140RK-05 | LEL detector, catalytic type, CSA version |
| 61-0140RKA | CH ₄ ppm detector, catalytic type, UL version |
| 61-0140RKA-05 | CH ₄ ppm detector, catalytic type, CSA version |
| 61-0190RK-CH4 | CH ₄ 0-100% LEL/0-5.00% volume detector, IR type, non-replaceable sensor |
| 61-0190RK-HC | HC LEL detector, IR type, non-replaceable sensor, propane calibration |
| 61-0191RK-01 | CO ₂ detector, IR type, non-replaceable sensor, 0 - 9,000 ppm |
| 61-0191RK-02 | CO ₂ detector, IR type, non-replaceable sensor, 0 - 5,000 ppm |
| 61-0191RK-03 | CO ₂ detector, IR type, non-replaceable sensor, 0 - 5% volume |
| 61-0191RK-05 | CO ₂ detector, IR type, non-replaceable sensor, 0 - 50.0% volume |
| 61-0191RK-10 | CO ₂ detector, IR type, non-replaceable sensor, 0 - 100% volume |
| 61-0192RK-CH4 | CH ₄ detector, IR type, non-replaceable sensor, 0 - 100% volume |
| 61-0197RK-CH4 | CH ₄ detector, IR type, replaceable sensor, 0 - 100% LEL |
| 61-0197RK-HC | HC detector, IR type, replaceable sensor, 0 - 100% LEL |
| 61-0198RK-01 | CO ₂ detector, IR type, replaceable sensor, 0 - 9,000 ppm |
| 61-0198RK-02 | CO ₂ detector, IR type, replaceable sensor, 0 - 5,000 ppm |

Table 20: Parts List

| Part Number | Description |
|--------------------|--|
| 61-0198RK-03 | CO ₂ detector, IR type, replaceable sensor, 0 - 5% volume |
| 61-0198RK-05 | CO ₂ detector, IR type, replaceable sensor, 0 - 50.0% volume |
| 61-0198RK-10 | CO ₂ detector, IR type, replaceable sensor, 0 - 100% volume |
| 61-0199RK-CH4 | CH ₄ detector, IR type, replaceable sensor, 0 - 100% volume |
| 61-5039RK-CH4 | Plug-in IR CH ₄ sensor, LEL range, for 61-0197RK-CH4 detector |
| 61-5039RK-HC | Plug-in IR HC sensor, LEL range, for 61-0197RK-HC detector |
| 61-5040RK-01 | Plug-in IR CO ₂ sensor, 0 - 9,000 ppm range (for 61-0198RK-01 detector) |
| 61-5040RK-02 | Plug-in IR CO ₂ sensor, 0 - 5,000 ppm range (for 61-0198RK-02 detector) |
| 61-5040RK-03 | Plug-in IR CO ₂ sensor, 0 - 5% volume range (for 61-0198RK-03 detector) |
| 61-5040RK-05 | Plug-in IR CO ₂ sensor, 0 - 10% volume range (for 61-0198RK-05 detector) |
| 61-5040RK-10 | Plug-in IR CO ₂ sensor, 0 - 100% volume range (for 61-0198RK-10 detector) |
| 61-5041RK-CH4 | Plug-in IR CH ₄ sensor, %vol range (for 61-0199RK-CH4 detector) |
| 65-1025RK | Plug-in oxygen sensor (for 65-2514RK and 65-2494RK detectors) |
| 65-2039RK | Plug-in H ₂ S sensor (for 65-2428-01 detector) |
| 65-2051-01 | CT-7 Series plug-in sensor, 0 - 3.00 ppm, 0 - 5.00 ppm, and 0 - 10.0 ppm Cl ₂ , with membrane (for 65-2302-CL2, 65-2302-CL2-5, and 65-2302-CL2-10 detectors) |
| 65-2052-01 | CT-7 Series plug-in sensor, 0 - 1.00 ppm ClO ₂ , 0 - 3.00 ppm ClO ₂ and 0 - 5.00 ppm ClO ₂ , with membrane (for 65-2302-CLO2, 65-2302-CLO2-3, and 65-2302-CLO2-5 detectors) |
| 65-2053-01 | CT-7 Series plug-in sensor, 0 - 500 ppm NH ₃ , with membrane (for 65-2302-NH3-5 detector) |
| 65-2054-01 | CT-7 Series plug-in sensor, 0 - 75.0 ppm NH ₃ , 0 - 100 ppm NH ₃ , and 0 - 200 ppm NH ₃ , with membrane (for 65-2302-NH3, 65-2302-NH3-1, and 65-2302-NH3-2 detectors) |
| 65-2300RK-ASH3 | ESM-01 detector, 0 - 1.50 ppm arsine (includes sensor) |
| 65-2300RK-CL-10 | ESM-01 detector, 0 - 10.0 ppm chlorine (includes sensor) |
| 65-2300RK-CL2 | ESM-01 detector, 0 - 3.00 ppm chlorine (includes sensor) |
| 65-2300RK-HCN | ESM-01 detector, 0 - 15.0 ppm hydrogen cyanide (includes sensor) |
| 65-2300RK-NH3 | ESM-01 detector, 0 - 75.0 ppm ammonia (includes sensor) |
| 65-2300RK-PH3 | ESM-01 detector 0 - 1.00 ppm phosphine (includes sensor) |
| 65-2300RK-SO2 | ESM-01 detector, 0 - 6.00 ppm sulphur dioxide (includes sensor) |
| 65-2302-CL2-3 | CT-7 Series detector, 0 - 3.00 ppm chlorine (includes sensor) |
| 65-2302-CL2-5 | CT-7 Series detector, 0 - 5.00 ppm chlorine (includes sensor) |
| 65-2302-CL2-10 | CT-7 Series detector, 0 - 10.0 ppm chlorine (includes sensor) |

Table 20: Parts List

| Part Number | Description |
|--------------------|--|
| 65-2302-CLO2-1 | CT-7 Series detector, 0 - 1.00 ppm chlorine dioxide (includes sensor) |
| 65-2302-CLO2-3 | CT-7 Series detector, 0 - 3.00 ppm chlorine dioxide (includes sensor) |
| 65-2302-CLO2-5 | CT-7 Series detector, 0 - 5.00 ppm chlorine dioxide (includes sensor) |
| 65-2302-HCN-15 | CT-7 Series detector, 0 - 15.0 ppm hydrogen cyanide (includes sensor) |
| 65-2302-NH3-75 | CT-7 Series detector, 0 - 75.0 ppm ammonia (includes sensor) |
| 65-2302-NH3-1 | CT-7 Series detector, 0 - 100 ppm ammonia (includes sensor) |
| 65-2302-NH3-2 | CT-7 Series detector, 0 - 200 ppm ammonia (includes sensor) |
| 65-2302-NH3-5 | CT-7 Series detector, 0 - 500 ppm ammonia (includes sensor) |
| 65-2428 | H ₂ S detector assembly, 0 - 100 ppm, CSA version (includes plug-in sensor) |
| 65-2428-01 | H ₂ S detector assembly, CSA version, for frequent-H ₂ S-exposure applications (includes plug-in sensor) |
| 65-2428-02 | H ₂ S detector assembly, 0 - 50 ppm, CSA version (includes plug-in sensor) |
| 65-2438 | CO detector assembly, 0 - 300 ppm, CSA version (includes plug-in sensor) |
| 65-2438-01 | CO detector assembly, 0 - 100 ppm and 0 - 200 ppm, CSA version (includes plug-in sensor) |
| 65-2494RK | Oxygen detector assembly, non-explosion proof, replaceable sensor type (includes plug-in sensor) |
| 65-2495RK | H ₂ S detector assembly, 0 - 100 ppm, non-explosion proof, replaceable sensor type (includes plug-in sensor) |
| 65-2496RK | CO detector assembly, 0 - 300 ppm, non-explosion proof, replaceable sensor type (includes plug-in sensor) |
| 65-2510RK | Oxygen detector, partial pressure type |
| 65-2511RK | Oxygen detector, capillary type |
| 65-2514RK | Oxygen detector, CSA version, capillary type (includes plug-in sensor) |
| 71-0305RK | <i>M2A Transmitter Operator's Manual (this document)</i> |
| 81-0002RK-01 | Calibration cylinder, 50% LEL hydrogen in air, 34 liter steel |
| 81-0002RK-03 | Calibration cylinder, 50% LEL hydrogen in air, 103 liter |
| 81-0004RK-01 | Calibration cylinder, 50% LEL propane in air, 34 liter steel |
| 81-0004RK-03 | Calibration cylinder, 50% LEL propane in air, 103 liter |
| 81-0007RK-01 | Calibration cylinder, 15% LEL hexane in air, 34 liter steel |
| 81-0010RK-01 | Calibration cylinder, 10% LEL (5000 ppm) methane in air, 34 liter steel |
| 81-0010RK-03 | Calibration cylinder, 10% LEL (5000 ppm) methane in air, 103 liter |
| 81-0012RK-01 | Calibration cylinder, 50% LEL methane in air, 34 liter steel |
| 81-0012RK-03 | Calibration cylinder, 50% LEL methane in air, 103 liter |
| 81-0013RK-01 | Calibration cylinder, 50% volume methane in nitrogen, 34 liter steel |

Table 20: Parts List

| Part Number | Description |
|--------------------|--|
| 81-0013RK-05 | Calibration cylinder, 50% volume methane in nitrogen, 58 liter |
| 81-0064RK-01 | Calibration cylinder, CO, 50 ppm in air, 34 liter steel |
| 81-0064RK-03 | Calibration cylinder, CO, 50 ppm in air, 103 liter |
| 81-0070RK-01 | Calibration cylinder, CO ₂ , 2,000 ppm in nitrogen, 34 liter steel |
| 81-0070RK-03 | Calibration cylinder, CO ₂ , 2,000 ppm in nitrogen, 103 liter |
| 81-0071RK-01 | Calibration cylinder, CO ₂ , 5,000 ppm in nitrogen, 34 liter steel |
| 81-0071RK-03 | Calibration cylinder, CO ₂ , 5,000 ppm in nitrogen, 103 liter |
| 81-0072RK-01 | Calibration cylinder, CO ₂ , 2.5% in nitrogen, 34 liter steel |
| 81-0072RK-03 | Calibration cylinder, CO ₂ , 2.5% in nitrogen, 103 liter |
| 81-0073RK-01 | Calibration cylinder, CO ₂ , 15% in nitrogen, 34 liter steel |
| 81-0073RK-03 | Calibration cylinder, CO ₂ , 15% in nitrogen, 103 liter |
| 81-0076RK-01 | Zero air calibration cylinder, 34 liter steel |
| 81-0076RK-03 | Zero air calibration cylinder, 103 liter |
| 81-0078RK-01 | Calibration cylinder, 100% nitrogen, 34 liter steel (used for setting oxygen zero) |
| 81-0078RK-03 | Calibration cylinder, 100% nitrogen, 103 liter (used for setting oxygen zero) |
| 81-0151RK-02 | Calibration cylinder, H ₂ S, 25 ppm in nitrogen, 58 liter |
| 81-0151RK-04 | Calibration cylinder, H ₂ S, 25 ppm in nitrogen, 34 liter aluminum |
| 81-0170RK-02 | Calibration cylinder, 5 ppm SO ₂ in nitrogen, 58 liter |
| 81-0170RK-04 | Calibration cylinder, 5 ppm SO ₂ in nitrogen, 34 liter aluminum |
| 81-0176RK-02 | Calibration cylinder, 25 ppm NH ₃ in nitrogen, 58 liter |
| 81-0176RK-04 | Calibration cylinder, 25 ppm NH ₃ in nitrogen, 34 liter aluminum |
| 81-0185RK-02 | Calibration cylinder, 0.5 ppm PH ₃ in nitrogen, 58 liter |
| 81-0185RK-04 | Calibration cylinder, 0.5 ppm PH ₃ in nitrogen, 34 liter aluminum |
| 81-0190RK-02 | Calibration cylinder, 5 ppm Cl ₂ in nitrogen, 58 liter |
| 81-0190RK-04 | Calibration cylinder, 5 ppm Cl ₂ in nitrogen, 34 liter aluminum |
| 81-0192RK-02 | Calibration cylinder, 2 ppm Cl ₂ in nitrogen, 58 liter |
| 81-0192RK-04 | Calibration cylinder, 2 ppm Cl ₂ in nitrogen, 34 liter aluminum |
| 81-0196RK-02 | Calibration cylinder, 10 ppm HCN in nitrogen, 58 liter |
| 81-0196RK-04 | Calibration cylinder, 10 ppm HCN in nitrogen, 34 liter aluminum |

Table 20: Parts List

| Part Number | Description |
|--------------------|--|
| 81-1050RK | Regulator, with gauge and knob, 0.5 LPM, for 17 liter and 34 liter steel calibration cylinders (cylinders with external threads) |
| 81-1051RK | Regulator, with gauge and knob, 0.5 LPM, for 34 liter aluminum/58 liter/103 liter calibration cylinders (cylinders with internal threads) |
| 81-1051RK-25 | Regulator, fixed flow, w/gauge & knob, 0.25 LPM, for 34 liter aluminum/58 liter/103 liter cylinders (Used to calibrate NH₃ ESM-01 M2A only) |
| 81-1103RK | Calibration cup, for 3/4 NPT IR detectors |
| 81-1117RK | Calibration cup, for catalytic LEL/ppm, CO, H ₂ S, replaceable-sensor-type IR, CT-7 Series, and oxygen detectors |
| 81-1138RK | Calibration cup, general (SO ₂), for all ESM-01 <u>except</u> Cl ₂ and NH ₃ , use 0.5 LPM flow |
| 81-1138RK-CL2 | Calibration cup, for ESM-01 Cl ₂ , use 0.5 LPM flow |
| 81-1138RK-NH3 | Calibration cup, for ESM-01 NH ₃ , use 0.25 LPM flow |
| 81-1190RK | Splashguard, for ESM-01 detector cap |
| 81-9029RK-02 | Calibration cylinder, 100 ppm NH ₃ in nitrogen, 58 liter |
| ES-1531-CO | CO sensor, plug-in (for 65-2438, 65-2438-01, and 65-2496RK detectors) |
| ES-1537-H2S | H ₂ S sensor, plug-in (for 65-2428, 65-2428-02, and 65-2495RK detectors) |
| ESM-015-NO | ESM-01 plug-in sensor, 0 - 100 ppm nitric oxide |
| ESM-01DH-ASH3 | ESM-01 plug-in sensor, 0 - 1.50 ppm arsine |
| ESM-01DH-D-HCN | ESM-01 plug-in sensor, 0 - 15.0 ppm hydrogen cyanide |
| ESM-01DH-D-SO2 | ESM-01 plug-in sensor, 0 - 6.00 ppm sulphur dioxide |
| ESM-0DH-PH3 | ESM-01 plug-in sensor, 0 - 1.00 ppm phosphine |
| ESM-01R-D-NH3 | ESM-01 plug-in sensor, 0 - 75.0 ppm ammonia |
| ESM-K01-D-CL2 | ESM-01 plug-in sensor, 0 - 3.00 ppm chlorine |
| ESM-K01D-CL2-10 | ESM-01 plug-in sensor, 0 - 10.0 ppm chlorine |
| NC-6205-01 | Hydrogen specific LEL detector, catalytic type, UL version |
| NC-6205-05 | Hydrogen specific LEL detector, catalytic type, CSA version |

Appendix A: Control Button Quick Reference Guide

The M2A's control buttons allow access to operational modes, resetting of alarms, and display of the Information Screen. Table 21 shows which button combinations perform these functions and which parameters are available for adjustment while in the operational modes. While in these modes, display prompts showing a "?" require you to respond by pressing either the UP/YES (for yes) or DOWN/NO (for no) button. To change parameter settings, use the UP/YES and DOWN/NO buttons to get the desired setting, then press and release the ENTER button to accept the setting.

Table 21: Control Button Quick Reference Chart

| Mode Entered or Function Performed | Button Combination | Adjustable or Viewable Parameters |
|---|---|--|
| Alarm Reset | Press and Release ENTER | n/a |
| Show Information Screen | Press and Hold DOWN/NO | <ul style="list-style-type: none"> • Input Voltage • M2A Version/Revision Information |
| Calibration Mode | Press and Hold UP/YES for 5 seconds | <ul style="list-style-type: none"> • Fresh Air Adjust • Span (or Zero for Oxygen) Adjust with Calibration Gas |
| Configuration Mode | Press and Hold UP/YES & ENTER for 5 seconds | <ul style="list-style-type: none"> • Alarm Levels • Increasing or Decreasing Alarms • Normally Energized or Normally De-energized Relays • Latching or Self-resetting Alarms • Alarm On Delay • Alarm Off Delay (if self-resetting) • Zero Suppression • Noise Filter • Calibration Time-out Period |
| Gas Type Mode | Press and Hold UP/YES and DOWN/NO for 5 seconds | Gas Type |
| Modbus Mode | Press and Hold DOWN/NO and ENTER for 5 seconds | <ul style="list-style-type: none"> • Enable or Disable Modbus • Slave ID • Baud Rate • Parity • Response Delay |

Appendix B: PLC and DCS Device Wiring

The M2A can be wired to a PLC or DCS device if desired.

1. Guide multi conductor shielded cable or cables or wires in conduit through the top conduit port of the junction box. The number of cables or wires needed will depend on whether any relays are used and whether the Modbus output is used. Use the following recommendations to determine how to wire the M2A:
 - If Modbus connections will not be used and only the PWR/SIG terminal strip connections will be used, use four conductor shielded cable or four wires in conduit for connections to the power/signal terminal strip.

Table 22: Wire Size for PWR/SIG Connections

| Max Distance to Controller w/18 Gauge Wire | Max Distance to Controller w/16 Gauge Wire | Max Distance to Controller w/14 Gauge Wire |
|---|---|---|
| 2,500 ft. | 5,000 ft. | 8,000 ft. |

- If the PWR/SIG terminal strip connections and one or more relays are used, route the connections to the M2A in conduit. Use shielded cable in the conduit for the PWR/SIG connections and unshielded cable or individual wires for the relay connections. Make sure any wire or cable used for relay wiring is appropriately rated for the power that it will carry.

NOTE: If shielded cable is used for the PWR/SIG connections, leave the cable shield's drain wire insulated and disconnected at the M2A. You will connect the opposite end of the cable's drain wire at the controller or device.

- If the M2A will be wired into a Modbus network, see "Chapter 8: RS-485 Modbus Output" on page 61.

See Figure 36 below for field wiring connections to the M2A.

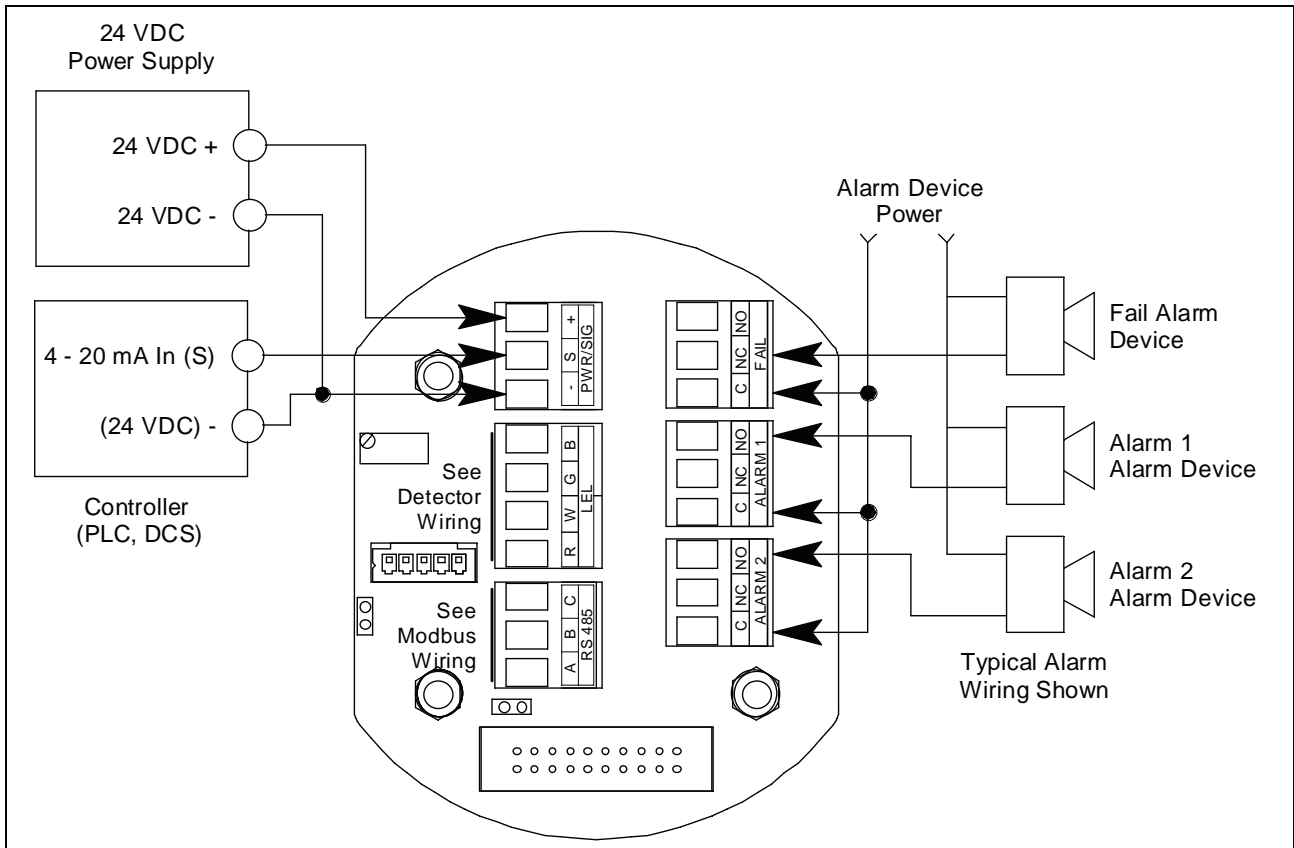

Figure 36: PLC and DCS Device Wiring

Appendix C: Function Code 16 Registers

The M2A supports Function Code 16 that allows writing to the M2A. There are 21 registers in this Function Code.

Register 1

Register 1 is the alarm 1 set point.
Value must be an integer. Any decimals are omitted.

Register 2

Register 2 is the alarm 1 trigger.
0=Decreasing
1=Increasing

Register 3

Register 3 is the alarm 1 relay state.
0=Normally De-Energized
1=Normally Energized

Register 4

Register 4 is the alarm 1 relay reset.
0=Latching
1=Self-Resetting

Register 5

Register 5 is the alarm 1 ON delay.
Integer value is in seconds.

Register 6

Register 6 is the alarm 1 OFF delay.
Integer value is in seconds.

Register 7

Register 7 is the alarm 2 set point.
Value must be an integer. Any decimals are omitted.
The decimal point location is the same as specified in Register 1 of Function Code 03.

Register 8

Register 8 is the alarm 2 trigger.
0=Decreasing
1=Increasing

Register 9

Register 9 is the alarm 2 relay state.
0=Normally De-Energized
1=Normally Energized

Register 10

Register 10 is the alarm 2 relay reset.
0=Latching

1=Self-Resetting

Register 11

Register 11 is the alarm 2 ON delay.
Integer value is in seconds.

Register 12

Register 12 is the alarm 2 OFF delay.
Integer value is in seconds.

Register 13

Register 13 is the zero suppression.
Toxics and LEL: 0%-6% Full Scale
Oxygen: 0%-0.7% Oxygen
Value must be an integer. Any decimals are omitted.

Register 14

Register 14 is the noise filter.
Integer value is in seconds (0-60 in 5 second increments).

Register 15

Register 15 is the calibration timeout.
Value is in minutes (5, 10, 15, 20, 25, or 30).

Register 16

Register 16 is explained in “Supported Modbus Functions” in the M2A manual.

Register 17

Register 17 is the calibration month (MSB) and day (LSB).
This is zero-based (e.g. January=0 and the 1st=0).

Register 18

Register 18 is the calibration year.

Register 19

Register 19 is for clearing change flags. When parameters are changed at the M2A, a flag is raised at the controller. This register can be used to clear those flags.

Table 23: Register 19, Clear Change Flags

| Bit(s) | Value & Field |
|--------|---|
| [15:2] | Unused |
| [1] | Write “1” to this bit to clear “Gas Type Changed” flag |
| [0] | Write “1” to this bit to clear “Configuration Changed” flag |

Register 20

Register 20 is the AutoZero Disable.
0=AutoZero Enabled
1=AutoZero Disabled

Register 21

Register 21 is the Remote Configuration Register.

0=No Remote Configuration

1=Reset Alarm