

65-2502RK/65-2510RK Oxygen Detector Operator's Manual

Part Number: 71-0074RK

Revision: A

Released: 3/1/11

WARNING

Read and understand this instruction manual before operating detector. Improper use of the detector could result in bodily harm or death.

Periodic calibration and maintenance of the detector is essential for proper operation and correct readings. Please calibrate and maintain this detector regularly! Frequency of calibration depends upon the type of use you have and the sensor types. Typical calibration frequencies for most applications are between 3 and 6 months, but can be required more often or less often based on your usage.

Product Warranty

RKI Instruments, Inc. warrants gas alarm equipment sold by us to be free from defects in materials, workmanship, and performance for a period of one year from date of shipment from RKI Instruments, Inc. Any parts found defective within that period will be repaired or replaced, at our option, free of charge. This warranty does not apply to those items which by their nature are subject to deterioration or consumption in normal service, and which must be cleaned, repaired, or replaced on a routine basis. Examples of such items are:

- a) Absorbent cartridges
- b) Pump diaphragms and valves
- c) Fuses
- d) Batteries
- e) Filter elements

Warranty is voided by abuse including mechanical damage, alteration, rough handling, or repair procedures not in accordance with the operator's manual. This warranty indicates the full extent of our liability, and we are not responsible for removal or replacement costs, local repair costs, transportation costs, or contingent expenses incurred without our prior approval.

THIS WARRANTY IS EXPRESSLY IN LIEU OF ANY AND ALL OTHER WARRANTIES AND REPRESENTATIONS, EXPRESSED OR IMPLIED, AND ALL OTHER OBLIGATIONS OR LIABILITIES ON THE PART OF RKI INSTRUMENTS, INC. INCLUDING BUT NOT LIMITED TO, THE WARRANTY OF MERCHANTABILITY OR FITNESS FOR A PARTICULAR PURPOSE. IN NO EVENT SHALL RKI INSTRUMENTS, INC. BE LIABLE FOR INDIRECT, INCIDENTAL, OR CONSEQUENTIAL LOSS OR DAMAGE OF ANY KIND CONNECTED WITH THE USE OF ITS PRODUCTS OR FAILURE OF ITS PRODUCTS TO FUNCTION OR OPERATE PROPERLY.

This warranty covers instruments and parts sold to users by authorized distributors, dealers, and representatives as appointed by RKI Instruments, Inc.

We do not assume indemnification for any accident or damage caused by the operation of this gas monitor, and our warranty is limited to the replacement of parts or our complete goods.

Table of Contents

Overview	1
Specifications	1
Description	2
Oxygen Detector	2
Junction Box	2
Installation	2
Mounting the Oxygen Detector	2
Wiring the Oxygen Detector	3
Startup	5
Introducing Incoming Power	5
Setting the Fresh Air Reading	5
Maintenance	6
Preventive Maintenance	6
Troubleshooting	7
Replacing the Oxygen Detector	7
Calibration Frequency	8
Calibration	8
Preparing for Calibration	8
Setting the Fresh Air Reading	9
Setting the Zero Reading	9
Returning to Normal Operation	9
Parts List	10

Overview

This manual describes the 65-2502RK oxygen detector. This manual also describes how to install, start up, maintain, and calibrate the detector when used with a gas monitoring controller. A parts list at the end of this manual lists replacement parts and accessories for the oxygen detector.

The 65-2502RK oxygen detector includes a junction box. This manual may also be used for the 65-2510RK oxygen detector which does not include a junction box and is normally mounted in one of a controller's conduit hubs. If you are using a 65-2510RK oxygen detector, disregard all references to the junction box and junction box terminal strip.

Specifications

Table 1 lists specifications for the oxygen detector.

Table 1: 65-2502RK/65-2510RK Specifications

Target Gas	Oxygen
Sampling Method	Diffusion
Detection Range	0 - 25.0% O ₂
Accuracy	± 0.5% O ₂
Response Time	90% in 30 seconds
Output	Millivolt (mV)

WARNING: *When using the 65-2502RK/65-2510RK, you must follow the instructions and warnings in this manual to assure proper and safe operation of the 65-2502RK/65-2510RK and to minimize the risk of personal injury. Be sure to maintain and periodically calibrate the 65-2502RK/65-2510RK as described in this manual.*

Description

This section describes the components of the oxygen detector. The detector includes the oxygen cell, detector housing, and detector connector. This section also describes the junction box.

Oxygen Detector

The sensing components of the detector are encapsulated within a conduit mounting black anodized aluminum housing. Through a series of chemical and electronic reactions, the detector produces a millivolt output that is proportional to the detection range. 3/4" NPT mounting threads at the top of the detector allow you to mount the detector to the junction box or a 3/4" NPT conduit fitting. Two color-coded leads extend from the top of the detector. The leads allow you to connect the detector to a controller.

Junction Box

The junction box allows you to install the oxygen detector at a mounting site that is remote from a controller, and it protects the detector wiring connections. Two conduit hubs allow you to mount the oxygen detector to the junction box and connect the wiring from the detector to a controller. Three spacers installed on the back of the junction box control the distance of the junction box from a mounting surface and ensure that there is enough room to install a calibration cup on the detector during calibration.

A terminal block within the junction box facilitates the wiring process. A cover on the front of the junction box allows access to the interior of the junction box.

Installation

This section describes procedures to mount the oxygen detector in the monitoring environment and wire the detector to a controller.

Mounting the Oxygen Detector

NOTE: If you are mounting a 65-2510RK, it does not include a junction box and is usually factory installed in one of a controller's conduit hubs or may be field installed using the 3/4" NPT threads on the end with the wires.

1. Select a mounting site that is representative of the monitoring environment. Consider the following when you select the mounting site.
 - Select a site where the detector is not likely to be bumped or disturbed. Make sure there is sufficient room to perform start-up, maintenance, and calibration procedures.
 - Select a site that is at normal breathing level.

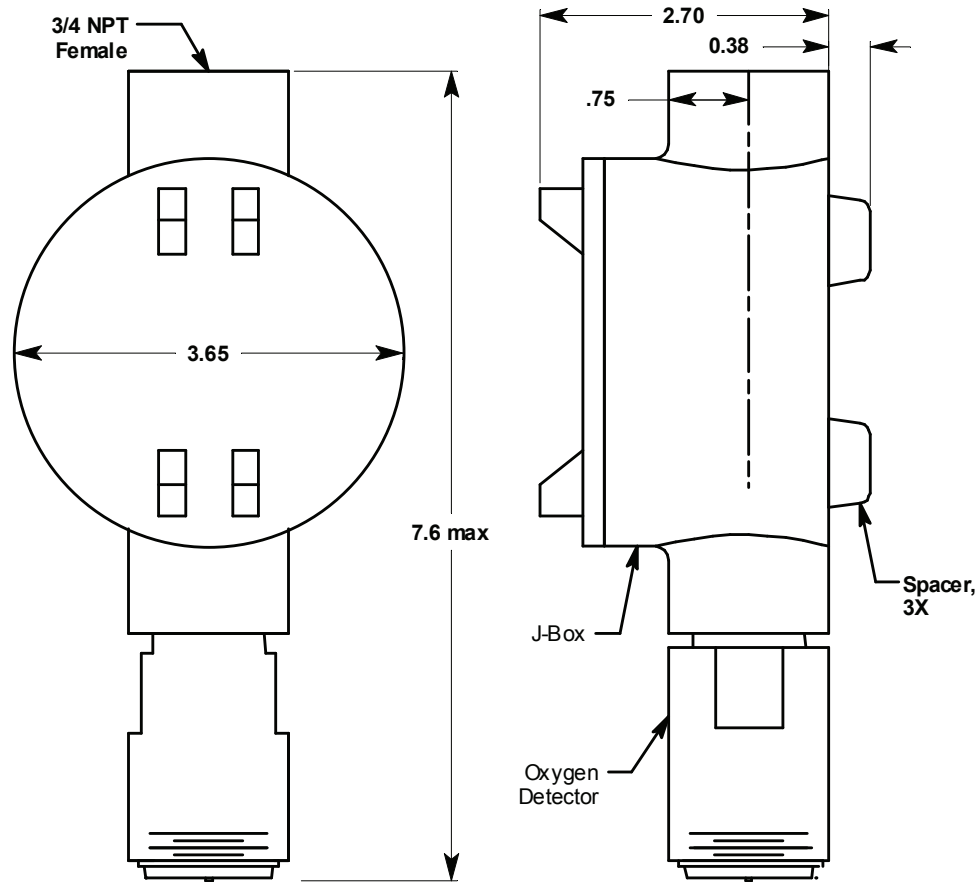

Figure 1: Mounting the Oxygen Detector

- At the mounting site you select, hang or mount the junction box with the detector facing down (see Figure 1).

Wiring the Oxygen Detector to a Controller

WARNING: Always verify that the power to the controller is off before you make wiring connections.

- Turn off the controller.
- Turn off or unplug incoming power to the controller.
- If the detector is mounted remotely from a controller using the junction box, proceed to step 4.

If the detector is mounted directly to a controller, it is normally factory wired. Confirm that the detector's white and green wires are connected to the appropriate controller detector terminals and skip to "Start Up" on page 5. See Figure 2, the controller operator's manual, and the controller's detector head specification sheet for the 65-2510RK detector for the wiring connections.

- Remove the junction box cover.
- Guide a two-conductor, shielded cable or two wires in conduit through the top conduit hub of the junction box. Use appropriate conduit fittings and construction technique for the environmental rating of the junction box. The junction box is rated NEMA 4X.

6. Connect the wires to the terminals using the terminal block.

CAUTION: *If using shielded cable, leave the shield drain wire insulated and disconnected at the detector. You will connect the opposite end of the cable's drain wire at the controller.*

7. Secure the junction box cover to the junction box.
8. Route the cable or wires in conduit leading from the detector through one of the conduit hubs at the controller. Use appropriate conduit fittings and construction technique for the environmental rating of the controller. RKI controllers are typically rated NEMA 4X.

CAUTION: *Do not route power and detector wiring through the same conduit hub. The power cable may disrupt the transmission of the detector signal to the controller.*

9. Connect the wires to the appropriate controller detector terminal strip. See the controller operator's manual and the controller's detector head specification sheet for the 65-2502RK detector.

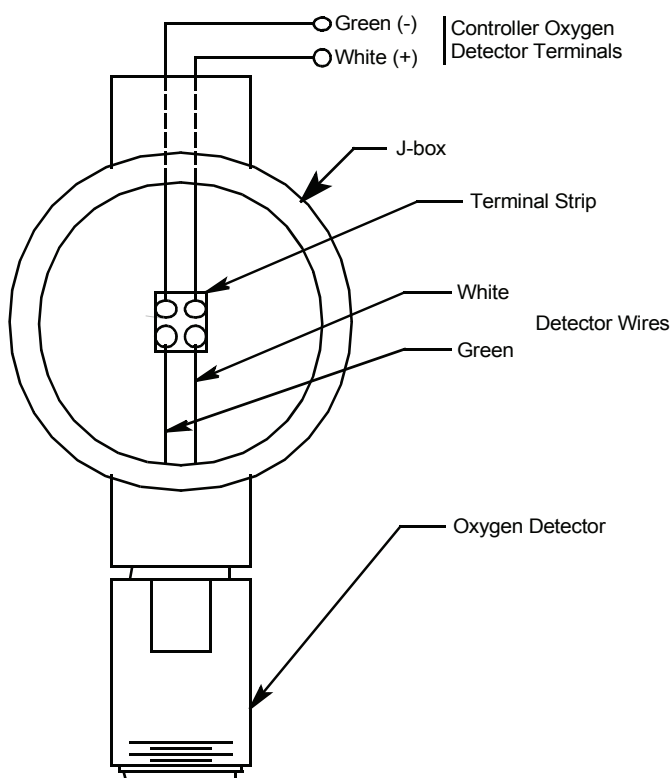

Figure 2: Wiring the Oxygen Detector to a Controller

10. If using shielded cable, connect the cable's drain wire to an available chassis ground at the controller. RKI controllers typically have a ground stud that is a convenient grounding location.

Start Up

This section describes procedures to start up the oxygen detector and place the detector into normal operation.

Introducing Incoming Power

1. Complete the installation procedures described earlier in this manual.
2. Verify that the power wiring to the controller is correct and secure. Refer to the controller instruction manual.
3. Turn on or plug in the incoming power to the controller, then turn on the controller.
4. Verify that the controller is on and operating properly. Refer to the controller operator's manual.

CAUTION: Allow the detector to warm up for 5 minutes before you continue with the next section, "Setting the Fresh Air Reading".

Setting the Fresh Air Reading

NOTE: If you can verify that the detector is in a fresh air environment (environment known to be of normal oxygen content and free of toxic and combustible gases), it is not necessary to apply zero air when verifying or setting the fresh air reading.

The procedure below describes applying zero emission air, usually called zero air, using a calibration kit that includes a calibration cup, calibration gas, sample tubing, and a fixed flow regulator with an on/off knob. RKI Instruments, Inc. recommends using a 0.5 LPM (liters per minute) fixed flow regulator.

1. Screw the calibration cup onto the bottom of the oxygen detector.
2. Screw the regulator into the zero air calibration cylinder.
3. Use the sample tubing to connect the regulator to the calibration cup.
4. Turn the regulator's on/off knob counterclockwise to open it. Gas will begin to flow.
5. Allow the gas to flow for two minutes.
6. Verify a reading of 20.9% oxygen at the controller.

If the display reading is 20.9% oxygen, the oxygen detector is in normal operation and start up is complete. Proceed to step 7 to disassemble the calibration kit.

If the display reading is not 20.9% oxygen, set the fresh air reading according to the controller's operator's manual.

7. Turn the regulator's on/off knob clockwise to close it.
8. Unscrew the regulator from the zero air calibration cylinder. For convenience, leave the sample tubing connected to the regulator and the calibration cup.
9. Unscrew the regulator from the cylinder and remove the calibration cup from the detector.
10. Store the components of the calibration kit in a safe and convenient place.

Maintenance

This section describes maintenance procedures. It includes preventive maintenance, troubleshooting, and component replacement procedures.

Preventive Maintenance

This section describes a preventive maintenance schedule to ensure the optimum performance of the oxygen detector. It includes daily, monthly, and quarterly procedures.

Daily

Verify a display reading of 20.9% oxygen at the controller. Investigate significant changes in the reading.

Monthly

This procedure describes a test to verify that the oxygen detector responds properly to oxygen deficiency.

WARNING: *The controller is not an active gas monitoring device during the response test procedure.*

NOTE: Performing a response test on the oxygen detector may cause alarms. Be sure to put the controller into its calibration program or disable external alarms before performing this test.

1. Place the controller into its calibration program or disable external alarms.
2. Verify that the controller display reading is 20.9% oxygen.
If the controller reading is not 20.9% oxygen, set the fresh air reading, then continue this procedure. See the controller instruction manual for directions to set the fresh air reading.
3. Exhale into the bottom of the oxygen detector housing.
4. Stop exhaling into the bottom of the detector, then verify that the reading on the controller display decreased from the normal reading of 20.9% oxygen.

NOTE: If the reading does not decrease, calibrate the detector as described in the Calibration section of this manual.

5. When the display reading rises above the decreasing alarm setpoint, return the controller to normal operation.

Quarterly

Calibrate the detector as described in the Calibration section of this manual.

Troubleshooting

The troubleshooting guide describes symptoms, probable causes, and recommended action for problems you may encounter with the oxygen detector.

NOTE: This troubleshooting guide describes detector problems only. See the controller instruction manual for problems you may encounter with the controller.

Table 2: Troubleshooting the Oxygen Detector

Condition	Symptom(s)	Probable Causes	Recommended Action
Fail Condition	<ul style="list-style-type: none"> Controller indicates a fail condition. 	<ul style="list-style-type: none"> The detector wiring is disconnected or misconnected. The detector is malfunctioning. 	<ol style="list-style-type: none"> Verify that the detector wiring is correct and secure. Calibrate the detector. If the fail condition continues, replace the detector. If the fail condition continues, contact RKI for further instruction.
Slow or No Response/ Difficult or Unable to Calibrate	<ul style="list-style-type: none"> Detector responds slowly or does not respond to response test. Unable to accurately set the fresh air or zero reading during calibration. Detector requires frequent calibration. <p><i>Note: Under "normal" circumstances, the detector requires calibration once every three months. Some applications may require a more frequent calibration schedule.</i></p>	<ul style="list-style-type: none"> The calibration cylinder is low, out-dated, or defective. The detector is malfunctioning. 	<ol style="list-style-type: none"> Verify that the calibration cylinder contains an adequate supply of a fresh test sample. If the calibration/response difficulties continue, replace the detector. If the calibration/response difficulties continue, contact RKI for further instruction.

Replacing the Oxygen Detector

- Turn off the controller.
- Turn off power to the controller.
- If the detector is installed directly on a controller, open the controller door.
If the detector is installed remotely from a controller in a junction box, remove the junction box cover.
- If the detector is installed directly on a controller, disconnect the detector leads from the detector terminal strip in the controller. Note the position of the color-coded leads as you remove them.
If the detector is installed remotely from a controller in a junction box, disconnect the detector leads from the terminal block in the junction box. Note the position of the color-coded leads as you remove them.
- Unscrew the detector from the controller conduit hub or junction box conduit hub.
- Guide the detector leads of the replacement detector through the controller conduit hub or junction box conduit hub, then screw the mounting threads of the detector into

the hub. If necessary for environmental conditions, apply thread sealant or teflon tape to the hub and/or detector threads to seal them.

7. If the detector is installed directly on a controller, connect the detector leads to the appropriate detector terminal strip terminals. See Figure 2 for wiring to a generic controller. See the controller operator's manual and the controller's detector head specification sheet for the 65-2510RK detector for wiring specific to your controller.

If the detector is installed remotely from a controller in a junction box, connect the detector leads to the terminal block the same way the old detector was wired (see Figure 2). See the controller operator's manual and the controller's detector head specification sheet for the 65-2502RK detector to verify the connections to the controller are correct.

8. If the detector is installed remotely from a controller in a junction box, reinstall the junction box cover.
9. Turn on power to the controller.
10. Turn on the controller and place into normal operation.

CAUTION: Allow the replacement detector to warm up for 5 minutes before you continue with the next step.

11. Calibrate the replacement detector as described in the Calibration section of this manual.

Calibration Frequency

Although there is no particular calibration frequency that is correct for all applications, a calibration frequency of every 3 months is adequate for most oxygen detector applications. Unless experience in a particular application dictates otherwise, RKI Instruments, Inc. recommends a calibration frequency of every 3 months for the oxygen detector.

If an application is not very demanding, for example detection in a clean, temperature controlled environment, and calibration adjustments are minimal at calibration, then a calibration frequency of every 6 months is adequate.

If the application is very demanding, for example if the environment is not well controlled, then more frequent calibration than every 3 months may be necessary.

Calibration

This section describes how to calibrate the oxygen detector. It includes procedures to assemble the calibration kit, set the fresh air reading, set the zero reading and return to normal operation. It describes the test using a calibration kit that includes a calibration cup, calibration gas, sample tubing, and a fixed flow regulator with an on/off knob. RKI Instruments, Inc. recommends using a 0.5 LPM (liters per minute) fixed flow regulator.

Preparing for Calibration

NOTE: Calibrating the oxygen detector may cause alarms. Be sure to put the controller into its calibration program or disable external alarms before calibrating.

1. Screw the calibration cup onto the detector housing.
2. Screw the regulator into the zero air calibration cylinder. Make sure the regulator is off. It is off when the on/off knob is turned all the way clockwise.
3. Use the sample tubing to connect the regulator to the calibration cup.

NOTE: If you can verify that the oxygen detector is in a fresh air environment, you do not need to apply zero air to the detector before adjusting the fresh air reading.

4. Put the controller into its calibration program. See the controller operator's manual for instructions to enter the calibration program.

Setting the Fresh Air Reading

1. Follow the directions in the controller's instruction manual for setting the fresh air reading to 20.9% oxygen.
2. When the instructions call for exposing the detector to zero air, turn the regulator's on/off knob counterclockwise to open it.
3. Allow the gas to flow to the detector for 2 minutes.
4. Set the fresh air reading according to the controller operator's manual.
5. Turn the regulator's on/off knob clockwise to close it.
6. Unscrew the regulator from the zero air calibration cylinder. Leave the sample tubing connected to the regulator and the calibration cup.

NOTE: Depending on the size of your zero air cylinder, it is possible that you will have a different regulator for the zero air cylinder and the nitrogen gas cylinder. If necessary to fit the nitrogen gas cylinder, change the regulator.

Setting the Zero Reading

1. Screw the regulator into the 100% nitrogen calibration cylinder.
2. Follow the instructions in the controller's operator's manual for setting the oxygen zero reading.
3. When the instructions call for exposing the detector to gas, turn the regulator's on/off knob counterclockwise to open it.
4. Allow the gas to flow to the detector for 2 minutes.
5. Set the zero reading according to the controller operator's manual.
6. Turn the regulator's on/off knob clockwise to close it.
7. Unscrew the regulator from the calibration cylinder.
8. Unscrew the calibration cup from the detector.

NOTE: For convenience, leave the components of the calibration kit connected by the sample tubing.

Returning to Normal Operation

1. When the display reading rises above the decreasing alarm setpoint, return the controller to normal operation.

NOTE: If you do not allow the oxygen reading to increase above the decreasing alarm point, then unwanted alarms may occur.

2. Verify that the controller display reading increases and stabilizes at 20.9% oxygen.
3. Store the components of the calibration kit in a safe and convenient place.

Parts List

Table 3 lists replacement parts and accessories for the oxygen detector.

Table 3: Parts List

Part Number	Description
06-1248RK	Sample tubing (3/16 in. x 5/16 in.; specify length when ordering)
18-04000RK-01	Junction box with spacers
65-2502RK	Oxygen detector including junction box.
65-2510RK	Oxygen detector, conduit-mounting, not including junction box
71-0074RK	<i>65-2502RK/65-2510RK Oxygen Detector Operator's Manual</i> (this document)
81-F301RK-LV	Calibration kit (34 liter)
81-0076RK-01	Zero air calibration cylinder (34 liter)
81-0078RK	Calibration cylinder (100% nitrogen, 17-liter)
81-0078RK-01	Calibration cylinder (100% nitrogen, 34-liter)
81-1050RK	Regulator with gauge and knob, 0.5 LPM, for 17 liter and 34 liter steel calibration cylinders
81-1117RK	Calibration cup