

SINGLE 45° BENDS

Determine where you want the center of the 45° bend on the tube. (dimension "L" Fig. (9) . Measure that distance and place a mark around the tube at "L" distance.

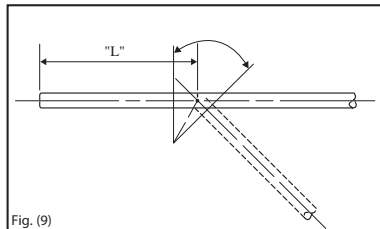
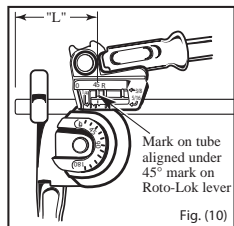

Fig. (9)



Position tube in bender as shown in Fig. (10) . The "L" mark should be directly under positioning line 45° for that tube diameter. With steady motion pull Roto-Lok lever around until "0" mark on lever is directly aligned with the 45° position line on the form wheel. Fig. (11)

Fig. (10)

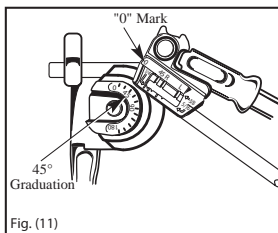

Fig. (11)

DOUBLE 45° OFFSET BENDS

1. Determine the desired centerline dimension between the legs of the offset (dimension "Y"). Fig. (12)
2. Determine the center of the first 45° bend. (dimension "L") Fig. (12) . Measure from end of tube and place mark at "L" distance. Fig. (13)
3. Determine center-to-center distance of 45° bend (dimension "X") in Fig. (12). Multiply offset dimension "Y" by 1.414. Measure from "L" mark on the tube and place a mark at "X" distance. Fig. (13)
4. Follow procedure for Single 45° Bends.

5. Reposition tube in bender as shown Fig. (14) . The measured mark "X" should be directly under the 45° position line on the Roto-Lok Lever. Insure the bend plane is in the correct relationship to the first bend. With a steady motion pull the Roto-Lok Lever around until the "0" on the Roto-Lok Lever is aligned with the 45° position line on the Form Lever. Fig. (15)

Note: Both "L" and "X" marks must be placed on tube prior to bending. Fig. (13)

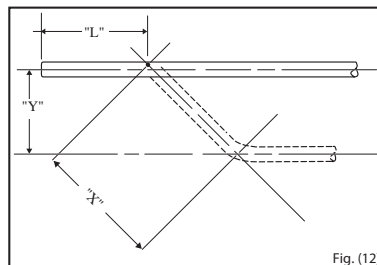

Fig. (12)

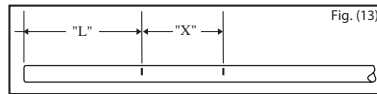

Fig. (13)

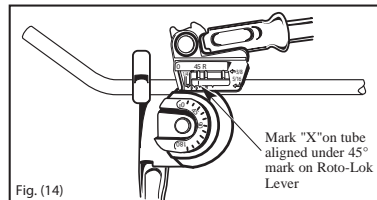

Fig. (14)

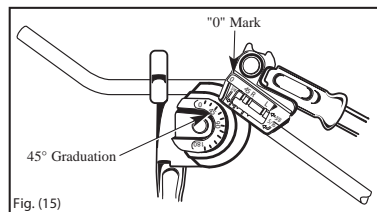

Fig. (15)

TRIPLE HEAD LEVER BENDER 470FH

Bends soft copper, aluminum, brass, thin wall steel and other tubing.

- For 3/16", 1/4", 5/16" and 3/8" O.D. tubing.
- Patented Roto-Lok™ lever repositions two-stage handle midway through bend for easy fabrication of bends up to 180° with reduced effort, better control and no crossing of handles.
- Made of lightweight, die cast aluminum.
- Compact design.
- Optimum bending radius – for each tubing size.
- Calibrated markings – for making accurate left-hand, right hand and offset bends.

GENERAL OPERATING INSTRUCTIONS

- 1.) Raise Roto-Lok Lever. Position tubing being used in the corresponding groove (for 3/16" tubing use 1/4 groove and data) as shown. It is important that the tube is engaged with the hook on the Form Wheel to prevent slippage (minimum of 1/8" should be past width of fixed tube hook to prevent flattening at the end of tube). Identification of groove sizes is located on the heel of the Roto-Lok Lever. Fig. (1)

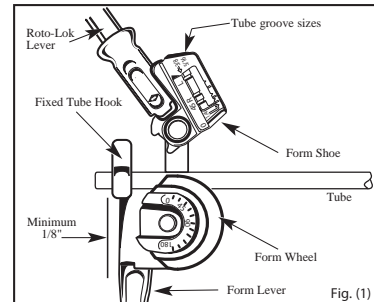

Fig. (1)

- 2.) Lower the Roto-Lok Lever to the 90° start position until the "0" on the Roto-Lok Lever and "0" on Form Wheel are aligned. Fig. (2)

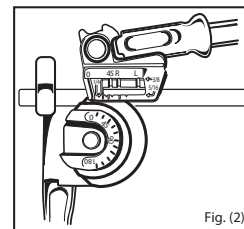

Fig. (2)

- 3.) Pull the Roto-Lok Lever down until the desired bend angle is obtained. Degree of bend is indicated when the "0" mark on the Roto-Lok Lever aligns with the desired degree position on the Form Wheel. Fig. (3) (example 90° Bend)

Note: All tubing will exhibit springback after a bend is completed. Springback is when the tube relaxes after being stressed; with soft copper tubing it is so minor compensation may not be necessary. With steel or stainless steel it could be from 2° to 5°.



30333 Emerald Valley Parkway • Glenwillow, OH 44139 • USA
Phone (440) 247.4600 • (888) 467.8665 Fax (440) 715.4699 • (800) 527.6383
www.imperial-tools.com
Form 470-FH5018

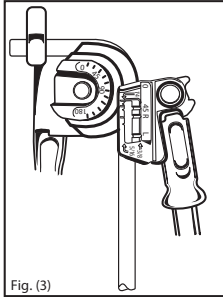

Fig. (3)

For ease in completing bends greater than 90° (180° max), pull Roto-Lok Lever to approx. 90° while maintaining the handle position. With your thumb and index finger reach up to the Index Release Collar and pull towards the grip. While the Collar is in the release position raise the handle upwards to approximately 80° and release the collar. Collar will snap into position as shown. Fig. (4)

IMPORTANT. Before proceeding with bend insure the stopping lug on the Roto-Lok Lever is in contact with the link and the Form Shoe length of groove is in contact with tube. This will insure that you are in the correct position to finish your bend to achieve the correct angle. Fig. (4)

Complete the downward motion of Roto-Lok Lever until the "0" on lever is aligned with the desired degree mark on form wheel. Fig. (5)

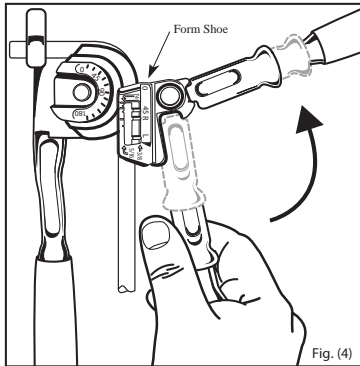

Fig. (4)

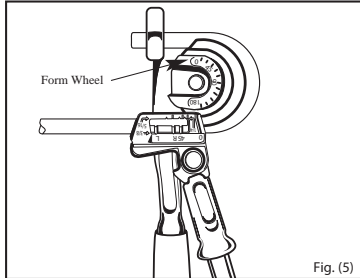

Fig. (5)

INSTRUCTIONS FOR MAKING ACCURATE 90° CENTERLINE BENDS

1. Determine the desired center line dimension. Dimension "L" in Fig. (6) .
2. Measure from end of tube (first bend) and place a mark around the tube at the "L" distance.
3. Position tube in the bender in the appropriate groove. The 470-FH has a unique window feature design, which allows for a location of the tube to the positioning marks for each size tube. Fig. (7)
4. If the end from which you measured is left of the tube fixed hook in Fig. 1, the measured mark on the tube should align with the "L" for the set of position marks for that diameter tube on the Roto-Lok Lever. Fig. (8)

The positioning marks on the Roto-Lok Lever are always in the same sequence from left to right: "45", "R" and "L". Fig. (7)

Example: Tube shown 3/8" Diameter (all examples and figures are shown using 3/8" tubing)

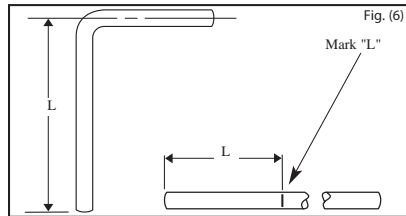

Fig. (6)

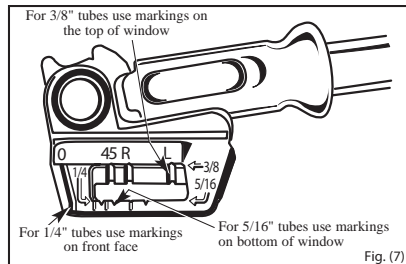

Fig. (7)

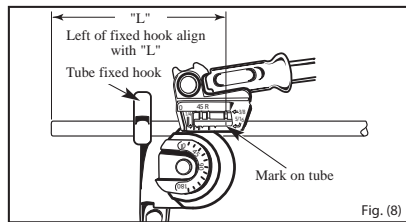

Fig. (8)

5. If the end from which you measured and placed your mark is placed to the right of the fixed hook, position the tube so the mark is directly aligned with the "R" for the set of position marks for that diameter tube on the Roto-Lok Lever. Fig. (8A) With a steady motion pull Roto-Lok Lever around until the "0" mark on the Roto-Lok Lever is directly aligned with the 90° position line on the FormWheel. Fig. (3)

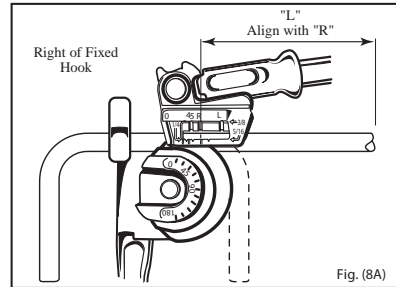

Fig. (8A)

LENGTH CORRECTION FACTORS FOR 45° AND 90° BENDS

To arrive at the exact tube length to fabricate a circuit the following method may be used.

Add all center-to-center dimensions of tube circuit. For each 90° bend subtract the amount shown in Chart "A". Circuits are usually dimensioned to square corners. Therefore the length of tube required is always less.

Chart A

Tube Diameter	Bend Radius	Correction Factor	
		90°	45°
1/4"	9/16"	.250 (1/4)	.031 (1/32)
5/16"	11/16"	.297 (19/64)	.031 (1/32)
3/8"	15/16"	.406 (13/32)	.047 (3/64)

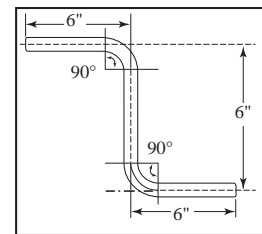

Example:
 Tube Size = 1/4"
 Number of bends = 2
 Bend Radius = 9/16"
 Sum of Centerline Dimensions = 18
 Correction Factor = 0.250

Factor Bends
 1) .250 x 2 = .500
 Sum
 2) 18 - 0.500 = 17.500
 3) 17.500 Tube Length Required