



---

# Installation and User Guide

## PT-Series HD

---

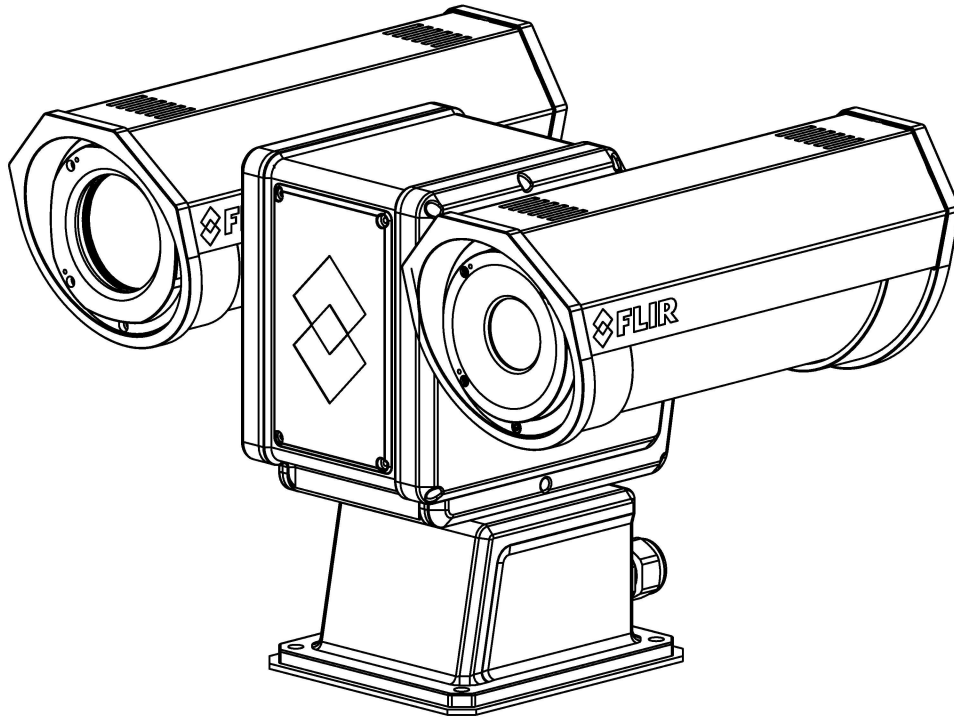

---

© 2019 FLIR Systems, Inc. All rights reserved worldwide. No parts of this manual, in whole or in part, may be copied, photocopied, translated, or transmitted to any electronic medium or machine readable form without the prior written permission of FLIR Systems, Inc.

Names and marks appearing on the products herein are either registered trademarks or trademarks of FLIR Systems, Inc. and/or its subsidiaries. All other trademarks, trade names, or company names referenced herein are used for identification only and are the property of their respective owners.

This product is protected by patents, design patents, patents pending, or design patents pending.

The contents of this document are subject to change.

Support:

### Important Instructions and Notices to the User:

Modification of this device without the express authorization of FLIR Systems, Inc., may void the user's authority under the FCC Rules to operate this device.

**Note 1:** This equipment has been tested and found to comply with the limits for a Class A digital device, pursuant to part 15 of the FCC Rules. These limits are designed to provide reasonable protection against harmful interference when the equipment is operated in a commercial environment. This equipment generates, uses, and can radiate radio frequency energy and, if not installed and used in accordance with the instruction manual, may cause harmful interference to radio communications. Operation of this equipment in a residential area is likely to cause harmful interference in which case the user will be required to correct the interference at his own expense. Shielded cables must be used to connect this device to other devices.

**Note 2:** If ferrites are supplied with this equipment, the equipment was tested for compliance with the FCC limits for a Class A digital device using power cables with the ferrites installed. When connecting one or two power cables to the equipment, the supplied ferrites must be used with this equipment.

#### Industry Canada Notice:

This Class A digital apparatus complies with Canadian ICES-003.

#### Avis d'Industrie Canada:

Cet appareil numérique de la classe A est conforme à la norme NMB-003 du Canada.

### Proper Disposal of Electrical and Electronic Equipment (EEE)



The European Union (EU) has enacted Waste Electrical and Electronic Equipment Directive 2002/96/EC (WEEE), which aims to prevent EEE waste from arising; to encourage reuse, recycling, and recovery of EEE waste; and to promote environmental responsibility.

In accordance with these regulations, all EEE products labeled with the crossed out wheeled bin either on the product itself or in the product literature must not be disposed of in regular rubbish bins, mixed with regular household or other commercial waste, or by other regular municipal waste collection means. Instead, and in order to prevent possible harm to the environment or human

health, all EEE products (including any cables that came with the product) should be responsibly discarded or recycled.

To identify a responsible disposal method nearby, please contact a local waste collection or recycling service, the original place of purchase or product supplier, or the responsible government authority in the area. Business users should contact their supplier or refer to their purchase contract.

### Document History

Version	Date	Comment
110	November 2017	V1.2.1.P06
120	March 2018	V1.2.1.P13
130	March 2019	V1.3.0.12
140	October 2019	Access cover gasket

# Table of Contents

---

## PT-Series HD Camera Installation

1.1 Camera Overview .....	5
1.2 Installation Overview .....	5
1.2.1 Camera Connection Options .....	5
1.2.2 Serial Communications Overview .....	6
1.2.3 Supplied Components .....	6
1.2.4 Required Components .....	6
1.3 Location Considerations .....	7
1.4 Bench Testing .....	7
1.5 Camera Mounting .....	7
1.5.1 Galvanic Isolation .....	7
1.5.2 Earth Ground Connection .....	8
1.5.3 Installation of Camera and Galvanic Isolation Kit .....	9
1.6 Camera Connections .....	12
1.6.1 Remove the Back Cover .....	12
1.6.2 Connecting power .....	13
1.6.3 Video Connections .....	14
1.6.4 Ethernet Connection .....	14
1.6.5 Serial Connection .....	14
1.6.6 Serial Communications Settings - Hardware DIP Switches .....	15
1.6.7 Back Cover Gasket .....	17
1.6.8 Cable Gland Sealing .....	17
1.7 PT-Series HD Camera Specifications .....	19

## Basic Operation and Configuration

2.1 IP Camera, ONVIF Profile S Compliant .....	21
2.1.1 Serial and/or IP Communications .....	21
2.1.2 Server Configuration .....	21
2.2 Camera Bench Test .....	21
2.2.1 Set IP Address using the FLIR Discovery Network Assistant (DNA) .....	22
2.3 Log into the Camera Web Page .....	23
2.3.1 Live Video Page .....	24
2.3.2 Camera Control and Status .....	25
2.3.3 Web Control Panel .....	25
2.4 Camera Configuration .....	27
2.4.1 Expert and Admin Accounts .....	28
2.4.2 Setup Menu .....	29
2.4.3 Maintenance Menu .....	34
2.4.4 Files Menu .....	50
2.5 Thermal Imaging Overview .....	52
2.6 Troubleshooting Tips .....	53

## Serial Address: Decimal To Binary Conversion

3.1 Address Conversion Table .....	56
------------------------------------	----

The PT-Series HD pan/tilt thermal security camera for medium- to long-range applications can be used with traditional analog video installations or IP video networks. It incorporates a high-sensitivity thermal camera with a choice of lenses and a long-range daylight camera all within a precision pan/tilt platform. The PT-602CZ HD pairs a cooled mid-wave focal plane array (FPA) thermal detector with the daylight camera.

This manual describes the installation of the PT-Series HD cameras. If help is needed during the installation process, please refer to [www.flir.com](#) for support. All installers and integrators are encouraged to take advantage of the training offered by FLIR; visit [www.flir.com/training](#) for more information.

This manual includes the following topics:

- Installation overview
- Mounting the camera and its components
- Connecting the electronics
- Bench testing the camera
- Configuration and operation of the camera
- Camera specifications

For safety, and to achieve the highest levels of performance from the camera system, follow the warnings and cautions in this manual when handling and operating the camera system.

## Warning!



If mounting the camera on a pole, tower or any elevated location, use industry standard safe practices to avoid injuries.

## Caution!

Except as described in this manual, do not open the camera for any reason. Disassembly of the camera (including removal of the cover) can cause permanent damage and will void the warranty.

Be careful not to leave fingerprints on the camera's infrared optics.

The camera requires a power supply of 24 Volts nominal. Operating the camera outside of the specified input voltage range or the specified operating temperature range can cause permanent damage.

*PT-Series Camera Mechanical Interface Control Document (ICD)* (FLIR Doc # 427-0075-XX-19)—available from the FLIR website, provides further details regarding mechanical dimensions and mounting for the PT-Series HD camera.

### 1.1 Camera Overview

The PT-Series HD camera is both an analog and an IP camera. The video from the camera can be viewed over a traditional analog video network or it can be viewed by streaming it over an IP network using MJPEG or H.264 encoding. Analog video will require a connection to a video monitor or an analog matrix/switch. The IP video will require a connection to an Ethernet network switch and the appropriate software for viewing the video stream.

### 1.2 Installation Overview



**Figure 1-1: PT-Series HD**

The PT-Series HD camera is intended to be mounted outdoors on a medium-duty fixed pedestal mount or wall mount commonly used in the CCTV industry. Cables will exit from the back of the camera housing. The mount must support up to 45 lbs (20 KG). The camera can be controlled through either serial or IP communications. The camera operates on 21 Vac to 30 Vac or 21 Vdc to 30 Vdc. In order to access the electrical connections and install the cables, it is necessary to temporarily remove the back cover of the camera housing. Ensure the back cover is replaced in the same orientation, with the two cable glands below the central pressure equalization vent.

#### 1.2.1 Camera Connection Options

Camera connections are made through water-tight cable gland seals on the rear of the camera. Refer to [Cable Gland Sealing, pg. 17](#) to ensure the glands are used correctly and the connections are sealed.

Analog video will require at least one connection to a video monitor or an analog video matrix switch. In most analog installations, two video connections will be used—one for the thermal camera video, and one for the daylight camera video. The camera provides two BNC connectors for these analog video channels.

An Ethernet connection is provided for IP video streaming and for command and control communications using a web browser.

For analog installations that are not using Ethernet/IP, a serial cable (RS232 or RS422) can be connected and used for command and control communications, supporting either Pelco D or Bosch protocols. It is recommended an Ethernet cable should also be installed to allow easy remote access for camera configuration, operation, and troubleshooting.

### Network Security

The camera supports IEEE 802.1x authentication when connected to a network supporting the following requirements:

- Network device (Authenticator) such as an Ethernet switch configured with 802.1x
- Authentication server supporting either TLS

Refer to [IEEE 802.1x Security, pg. 35](#) for information on how to configure the LAN settings.

### 1.2.2 Serial Communications Overview

The installer must decide if the serial communications settings will be configured via hardware (DIP switch settings) or software (default). If the camera has an Ethernet connection, then generally it is easier (and more convenient) to make configuration settings via software. Then configuration changes can be made over the network without physically accessing the camera. Also the settings can be saved to a file and backed up or restored as needed.

If the camera is configured via hardware, then configuration changes in the future may require accessing the camera on a tower or pole, dismounting it, and removing the back and so on. If the camera does not have an Ethernet connection, the DIP switches must be used to set the serial communication options.

### 1.2.3 Supplied Components

The PT-Series HD camera ships with these standard components:

- Multi-sensor pan/tilt camera unit
- Galvanic isolation kit (PN 4204960)
- Noise suppression ferrite
- Cable glands and spare parts kit

### 1.2.4 Required Components

The installer will need to supply the following items; the cable lengths are specific to the installation.

- 24 Vdc or 24 Vac power supply

#### Note

A single ferrite is supplied with this equipment, the equipment was tested for compliance with the FCC limits for a Class A digital device using the ferrite installed on the system power cable. When connecting one or two power cables to the equipment, the supplied ferrite must be installed with this equipment. A power installation using metal conduit does not require installing the ferrite.

- Electrical cables, for system power and heater power; 3-conductors are required for system power (one ground) and two conductors are required for heater power (no ground). The wire gauge must be determined by cable length and supply voltage. A single 5-conductor, shielded cable or two individual cables may be used. Refer to [Figure 1-4 on page 12](#) for additional information.
- Camera grounding strap
- Coaxial RG59U video cables and a 90° BNC adapter at the camera end for analog video

- Shielded CAT6 Ethernet cable for streaming video, control, and for software updates. CAT5e Ethernet cable may be adequate in many installations except when closely installed with power cables in demanding video streaming networks.
- Serial cable for serial communications—optional
- Miscellaneous electrical hardware, camera mount (with stainless steel washers and bolts), connectors, and tools

### 1.3 Location Considerations

Install the camera in a location that will allow access for regular periodic cleaning (fresh water rinse), inspection of mounting integrity and mechanical soundness, and preventative maintenance. Ensure the camera and the camera mount are routinely inspected on a periodic basis.

The camera will require connections for power, communications (IP Ethernet, serial), and video (analog, IP digital).

- Ensure the 360° pan and 180° tilt exclusion zone is free of all obstructions.
- Install all cameras with an easily accessible Ethernet connection to support future software updates.
- Ensure that cable distances do not exceed the specifications and that cables adhere to all local and industry standards, codes, and best practices.

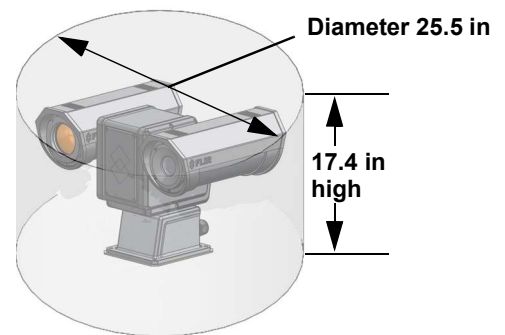

**Maximum keep-out cylinder**

### 1.4 Bench Testing

Connect the power, video, serial, and Ethernet connections and confirm that the video is displayed on a monitor when the power is turned on. Confirm the camera can be controlled by moving it (pan/tilt). For configuration and basic setup information using the onboard web server, refer to [Basic Operation and Configuration, pg. 21](#).

### 1.5 Camera Mounting

#### Caution!

Ensure that the camera base is electrically isolated and properly grounded when it is secured to its mount. Contact between the stainless steel fasteners and any bare aluminum may cause galvanic corrosion which will shorten the life of the installation and may void the camera warranty.

Galvanic isolation is critical in preventing corrosion. Proper installation of galvanic isolation pad and washers is important for long product life.

There are two critical steps related to proper galvanic isolation camera mounting:

- Installation of galvanic isolation kit
- Proper grounding (bonding) to earth ground

#### 1.5.1 Galvanic Isolation

The Galvanic Isolation Kit (FLIR PN 4204960) is for use with all PT-Series HD cameras. The isolation plate and nylon shoulder or flat washers provide electrical isolation between the stainless

steel fasteners and the aluminum camera base, and electrically isolates the complete PT-Series HD camera from the customer mount. Galvanic isolation is critical in preventing corrosion. Proper installation of galvanic isolation pad and washers is important for long product life. Refer to [Installation of Camera and Galvanic Isolation Kit, pg. 9](#) for specific instructions.

### 1.5.2 Earth Ground Connection

Earth ground connection is very important to protect PT-series from surge induced failures and corrosion caused by stray current/ground loops. Attach ground wire (16 AWG or larger) to ground lug on access panel. Use the large hex nut to secure ground wire to stud on access panel. Ground stud is #8-32 thread.



#### Caution!

When lifting the camera use the camera body and base, not the tubes.

## PT-Series HD Camera Installation

PT-Series HD cameras must be mounted upright on top of the mounting surface, with the base below the camera. The unit should not be hung upside down.

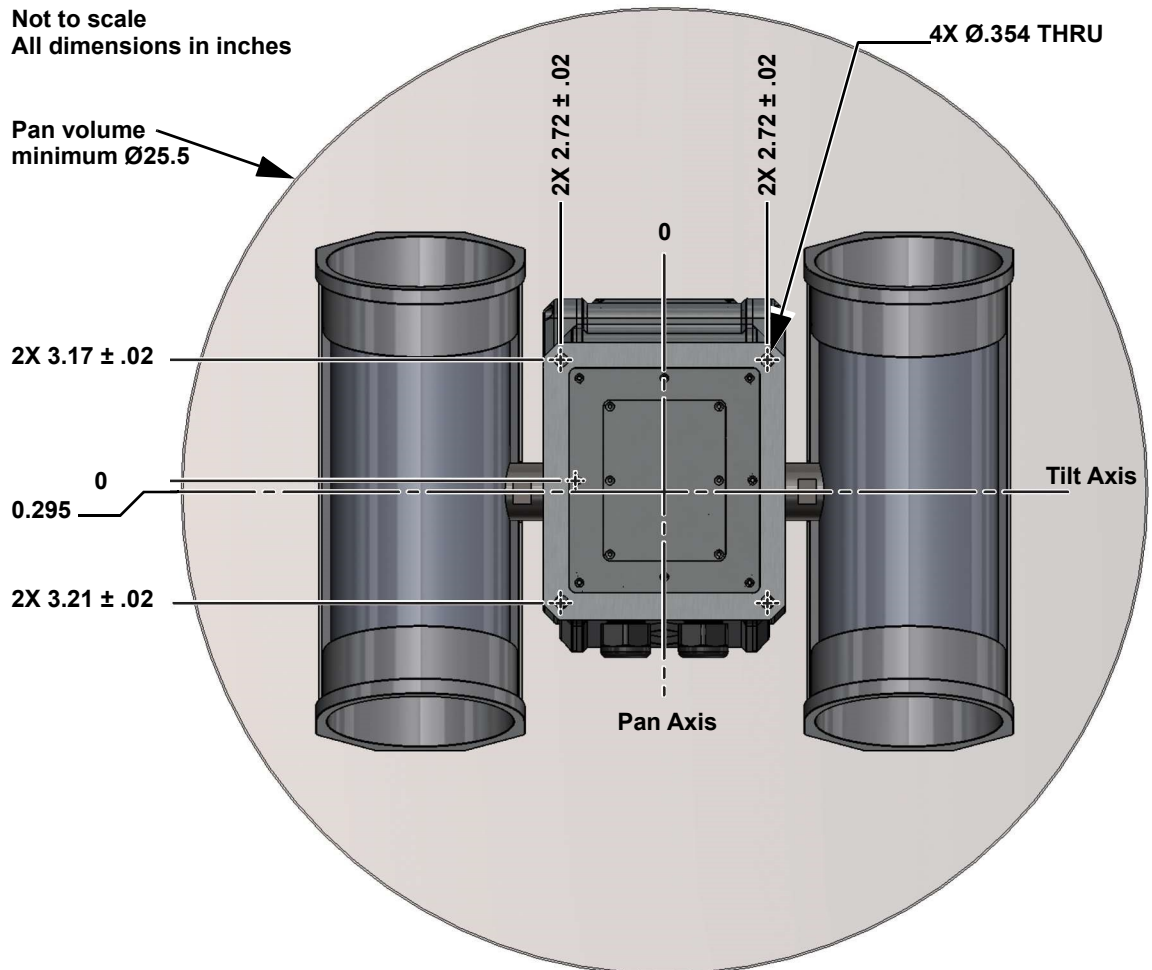

Figure 1-2: PT-Series HD Camera Mounting

### 1.5.3 Installation of Camera and Galvanic Isolation Kit

#### Important Safeguards and Warnings

- Installation and servicing should be done by qualified installation and service personnel only.
- Installation should be done according to all local and national electrical and mechanical codes, using only approved materials.

#### Warning!



Before drilling into walls or ceilings for mounting the camera, verify that areas behind these positions do not contain electrical or other utility service lines. Serious injury or death may result from failure to heed this warning.

- Once the mounting location has been selected, verify both sides of the mounting surface are accessible and free of utility service lines or other obstructions.
- Use stainless steel hardware to fasten mounts to outdoor surfaces.
- Use a thread locking compound such as Loctite 242 or equivalent with all metal to metal threaded connections.
- To prevent damage from water leakage when installing outdoors, apply sealant around the bolt holes between the mount and the mounting surface.

**Caution!**

Following this procedure is critical to maintaining the warranty on your PT-Series HD product. Failure to follow these instructions can potentially void the camera warranty.

**Table 1-1: Kit Contents**

Description	Qty	
Isolation plate	1	
M8 nylon flat washer <sup>a</sup>	6	Two extra pieces of each attaching part are supplied in the kit.
M8 nylon shoulder washer	6	
M8 split washer, S.S.	6	
M8 washer, S.S.	6	
Tef-Gel TG .25, 3 cc syringe <sup>a</sup>	optional	

- a. Use the alternate nylon flat washers and Tef-Gel lubricant on fasteners for PT-Series HD camera bases with mounting holes that are too small to accept the shoulder washers. A syringe of Tef-Gel will be supplied in the mounting kit when the nylon flat washer is required.

- Step 1** Determine the correct positioning of the isolation plate (See [Figure 1-3 on page 11](#)).
- Step 2** Place the isolation plate and the camera on the mounting structure aligning the bolt holes or studs.
- Step 3** Install nylon shoulder washers (4x) or nylon flat washers (4x) onto camera base. If using nylon flat washers, apply a generous coat of Tef-Gel filling all gaps and voids.
- Step 4** Secure the camera using 5/16" or M8 fasteners (4x) with stainless steel flat washers and split washers on top of the nylon washers.

Step 5 Ensure the camera is properly grounded. FLIR requires using a 14 AWG to 16 AWG grounding strap anchored to the ground lug on the back plate of the camera housing and then terminated to the nearest earth-grounding point.

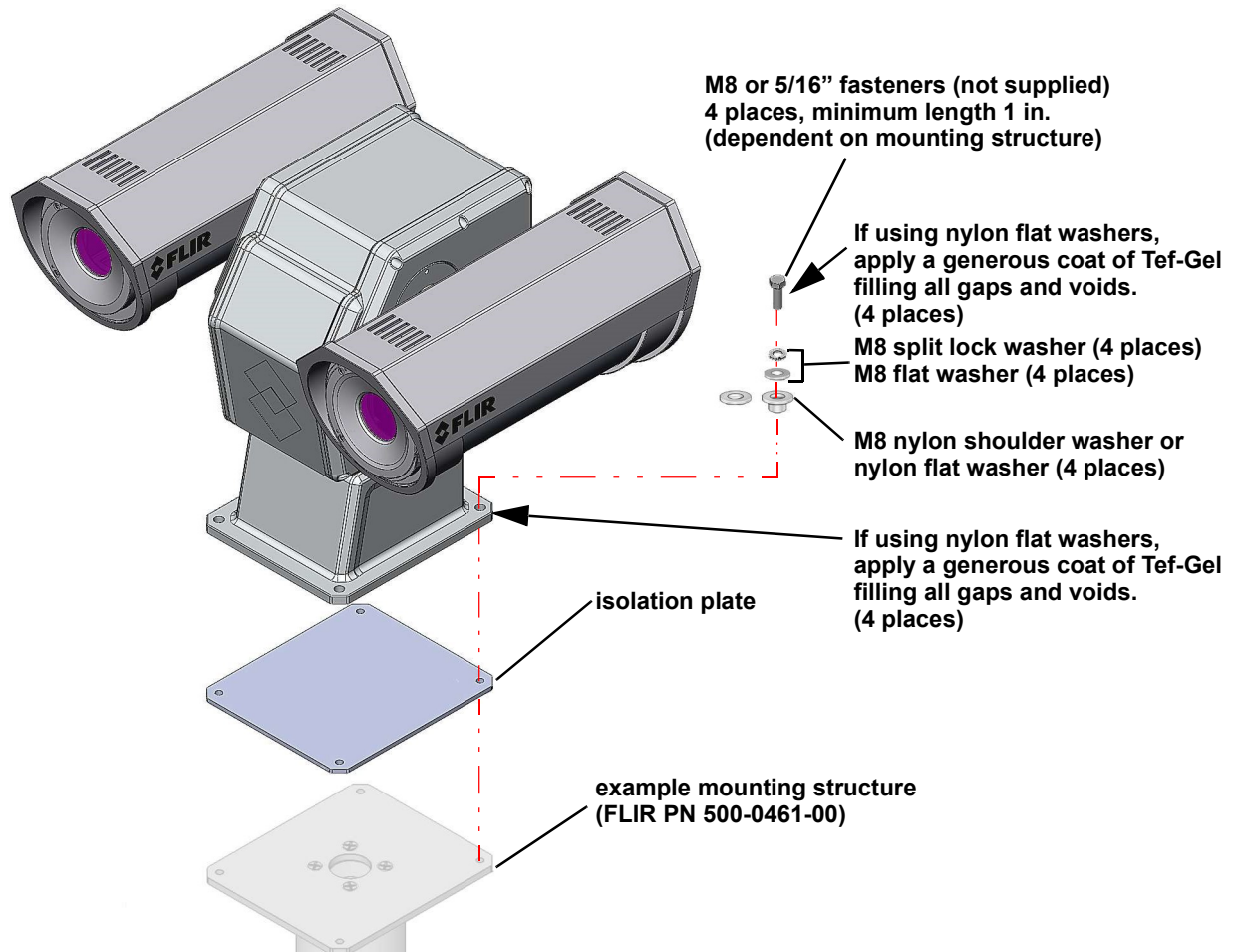

Figure 1-3: PT-Series HD Galvanic Isolation Kit (PN 4204960)

## 1.6 Camera Connections

### 1.6.1 Remove the Back Cover

Use a 2.5 mm hex key to loosen the captive screws and remove the cover, exposing the connections at the back of the camera. There is a grounding wire connected between the case and the back cover

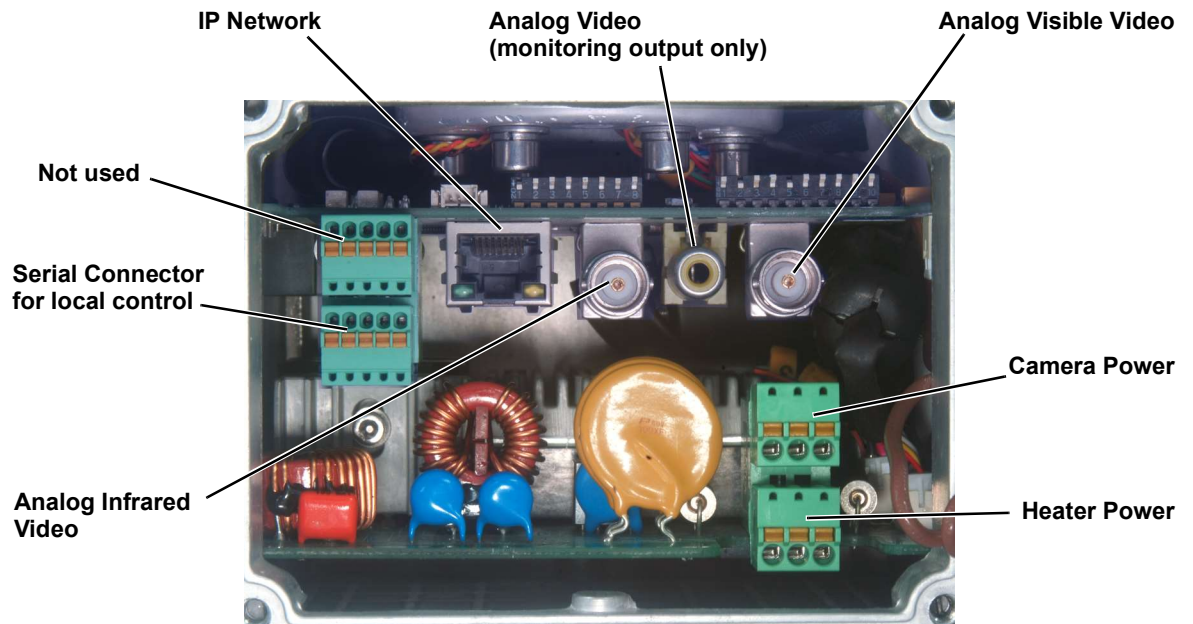
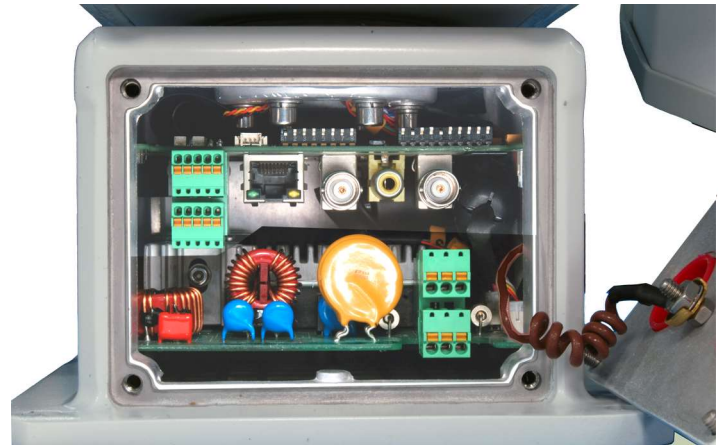

Figure 1-4: PT-Series HD Camera Connections

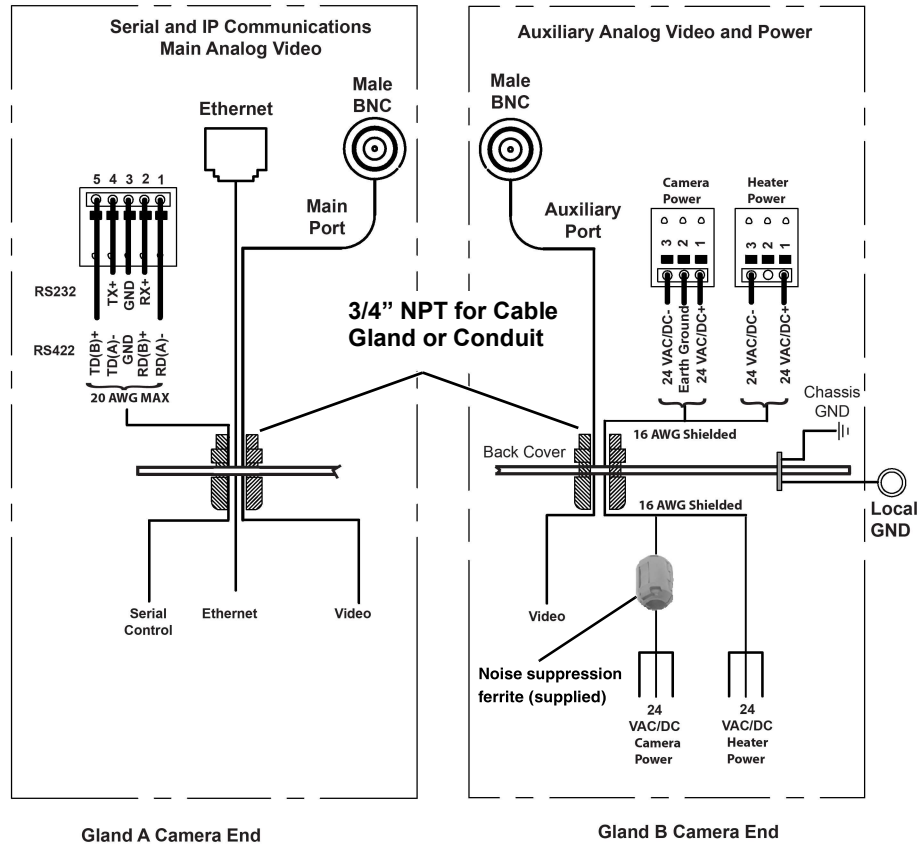

Figure 1-5: PT-Series HD Camera Connection Schematic

### 1.6.2 Connecting power

The camera itself does not have an on/off switch. Generally a circuit breaker will be used to apply or remove power to the camera. If power is supplied to it, the camera will be in one of two modes: Booting Up or Powered On.

The power cables supplied by the installer must use wires that are sufficient size gauge (16 AWG recommended) for the supply voltage and length of the cable run. Always follow local building codes!

To satisfy FCC requirements, the supplied noise suppression ferrite must be installed on the camera system power cable unless power cables are enclosed in metal conduit. Refer to Figure 1-4.

Note that the heater power cable requires two-wire power. Do not connect to the power supply ground.

Ensure the camera is properly grounded. Typical to good grounding practices, the camera chassis ground should be provided using the lowest resistance path possible. FLIR requires using a grounding strap anchored to the grounding lug on the back plate of the camera housing and connected to the nearest earth-grounding point.

**Note**

The terminal blocks for power connections will accept a maximum 16 AWG wire size.

### Lens Heaters

The lens heaters are intended to provide lens de-fogging and de-icing in the event of:

- A power interruption which disables the camera for an extended period, and
- Freezing rain which fully covers the lens and obstructs the image.

The PT-Series HD cameras are shipped from the factory with the lens heaters enabled. The lens heaters are configured to dynamically maintain the camera window at a constant temperature.

The lens heaters may be turned on manually from the Live Video web page (De-Ice button). Refer to [Web Control Panel](#), pg. 25. The heaters, when turned on manually, will run for approximately one hour unless turned off either by the user (De-Ice button) or the thermostat control.

### 1.6.3 Video Connections

The analog video connections on the back of the camera are BNC connectors. The camera also provides an RCA video connector that can be used to temporarily monitor the daylight camera (DLTV) video output.

The video cables used should be rated as RG59U or better to ensure a quality video signal.

#### Note

Insert the cable through the cable glands on the enclosure before terminating and connecting them. In general, the terminated connectors will not fit through the cable gland. If terminated, it is possible to make a clean and singular cut in the gland seal to install the cable into the gland seal.

### 1.6.4 Ethernet Connection

The cable gland seal is designed for use with shielded Ethernet cable.

#### Note

Insert the cable through the cable glands on the enclosure before terminating and connecting them. In general, the terminated connectors will not fit through the cable gland. If terminated, it is possible to make a clean and singular cut in the gland seal to install the cable into the gland seal.

### 1.6.5 Serial Connection

For serial communications, it is necessary to set the parameters such as the signaling standard (RS-232 or RS-422), baud rate, number of stop bits, parity and so on. It is also necessary to select the communication protocol used (either Pelco D or Bosch) and the camera address. By default, the serial interface uses Pelco D, RS-422 standard, 9600 baud rate, 8/1/none, and address 1.

#### Note

Typical Bosch systems operate using a biphasic connection. FLIR cameras do not accept biphasic signals directly. It may be necessary to install a biphasic converter in order to use the Bosch protocol.

Connect the wires of the serial cable as show in [Figure 1-4 on page 12](#). When using the RS-422 standard, ensure the transmit pair of the camera goes to the receive pair of the other device, and vice versa.

#### Note

The terminal blocks for serial connections will accept a maximum 20 AWG wire size.

**Note**

The serial communications parameters for the PT-Series HD camera are set or modified either via hardware DIP switch settings or via software, through a web browser interface. A single DIP switch (SW103-9), Software Override determines whether the configuration comes from the hardware DIP switches or the software settings.

**Note**

The DIP switches are only used to control serial communications parameters. Other settings, related to IP camera functions and so on, must be modified via software (using a web browser).

**1.6.6 Serial Communications Settings - Hardware DIP Switches**

The camera has two blocks of DIP switches that are used to configure the serial communications settings. One block of switches has 8 switches and is used to set the serial address (or ID) of the camera. The other block of switches has 10 switches and is used to set baud rate, hardware protocol (RS-232 or RS-422), serial protocol (Pelco D or Bosch), and Software Override.

The figure below shows the locations of dip switches SW102 and SW103.

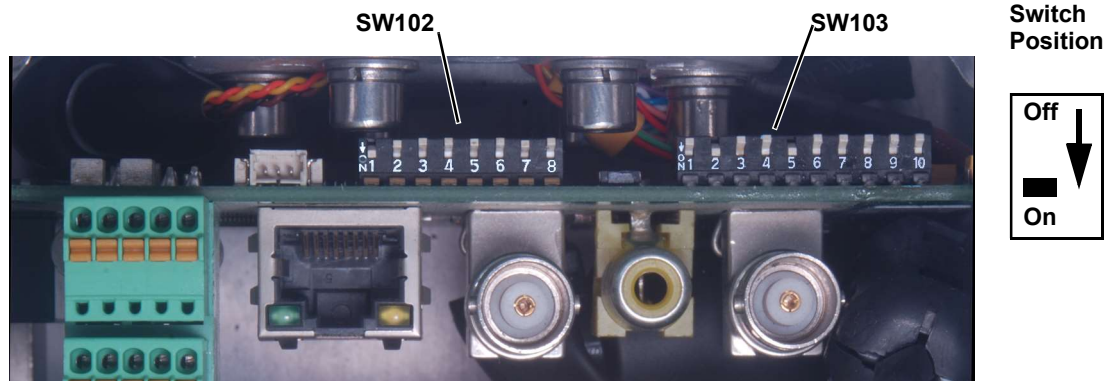

**Figure 1-6: PT-Series HD Serial Communications Configuration**

When the Software Override DIP switch is set to the Off position (as it is by default), all of the other DIP switches will be ignored, and configuration changes must be made through software. If the switch is set to the On position, all configuration settings related to serial communications are made with the DIP switches, and changes that are made via software (with a web browser) will be ignored.

**Serial Address:** Use the block of switches on the left (SW102) to set the serial address of the camera. The available range of values is from decimal 1 to 255. The dip switches are interpreted as a binary number, with switch 1 representing the least significant bit (the switches are in the reverse order of the bits). For convenience, a table of serial addresses and their binary equivalents is included at the end of the manual. Refer to [Serial Address: Decimal To Binary Conversion, pg. 56](#)

**Table 1-2: Dip Switch Address/ID Settings—SW101**

ID	Sw 1 LSB	Sw 2	Sw 3	Sw 4	Sw 5	Sw 6	Sw 7	Sw 8 MSB
1	On	Off	Off	Off	Off	Off	Off	Off

**Table 1-2: Dip Switch Address/ID Settings—SW101**

ID	Sw 1 LSB	Sw 2	Sw 3	Sw 4	Sw 5	Sw 6	Sw 7	Sw 8 MSB
2	Off	On	Off	Off	Off	Off	Off	Off
3	On	On	Off	Off	Off	Off	Off	Off
...	...	...	...	...	...	...	...	...
255	On	On	On	On	On	On	On	On

**Other Serial Communication Parameters:** The tables below defines the switch locations, bit numbering and on/off settings used in controlling the other serial communication parameters.

**Table 1-3: Dip Switch Settings—SW103**

	Settings		Description
	Bit 1	Bit 2	
<b>Baud rate:</b> This is the baud rate of the system user serial port. The available values are 2400, 4800, 9600, 19200 kbaud.	OFF	OFF	2400
	ON	OFF	4800
	OFF	ON	9600
	ON	ON	19200
<b>Camera Control Protocol:</b> This is the communication protocol selected for the system when operating over the serial port. The available protocols are Pelco-D and Bosch.	<b>Bit 3</b>	<b>Bit 4</b>	
	OFF	OFF	Pelco-D
	ON	OFF	NA
	OFF	ON	Bosch
<b>Serial Communication Standard:</b> This determines the electrical interface selected for the user serial port. The available settings are RS422 and RS232.	ON	ON	NA
	OFF	OFF	NA
	ON	OFF	RS422
	OFF	ON	RS232
Not Used	ON	ON	N/A
	<b>Bit 7</b>	<b>Bit 8</b>	
	X	X	
	X	X	
<b>Software Override DIP Switch:</b> This setting determines whether the system will use software settings for configuration or if the dip switch settings will override the software settings. Default is Off.	X	X	
	<b>Bit 9</b>		
	OFF		Software select
Not Used	ON		Hardware select
	<b>Bit 10</b>		
	X		

### 1.6.7 Back Cover Gasket

When preparing to re-attach the back cover, make sure that the gasket rests securely in the groove so that attaching the cover does not cut or otherwise damage the gasket. The picture below shows the black gasket properly in place.

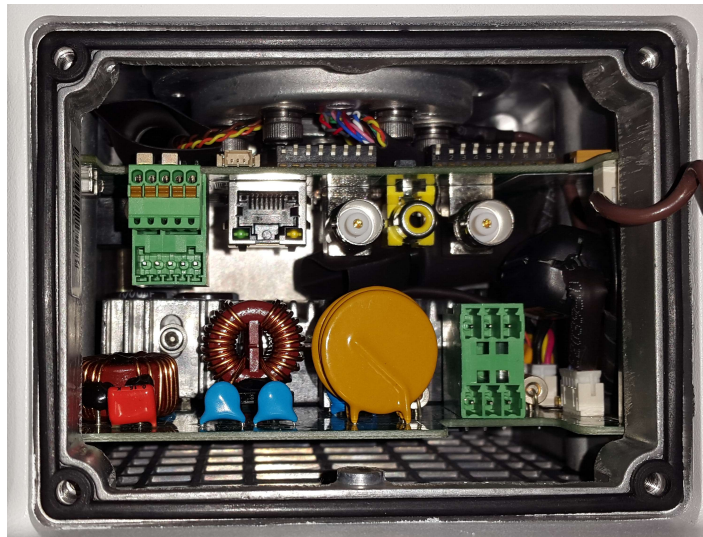

If possible, lay the camera down to install the gasket and cover. If doing so is not possible, before installing the cover, apply a small amount of O-ring lubricant to the gasket to help hold it in place.

### 1.6.8 Cable Gland Sealing

Proper installation of cable sealing glands and use of appropriate elastomer inserts is critical to long term reliability. Cables enter the camera mount enclosure through liquid-tight compression glands. Be sure to insert the cables through the cable glands on the enclosure before terminating and connecting them (the connectors will not fit through the cable gland). Leave the gland nuts loosened until all cable installation has been completed. Inspect and install gland fittings in the back cover with suitable leak sealant and tighten to ensure water tight fittings. Teflon tape or pipe sealant (for example DuPont RectorSeal T™) are suitable for this purpose.

#### Cable Glands and Spare Parts Kit

The kit contains the two 3/4" cable glands and gland seal plugs required for non-conduit installations.

The remaining parts included in the kit are:

- a spare ground wire
- a spare ground nut and lock washer
- two spare power terminal block plugs
- two spare serial port terminal block plugs
- four spare F-Series back cover screws
- four spare PT-Series back cover screws



### Cable Gland Seal Inserts

Cables may be between 0.23" to 0.29" OD. Up to six cables may be installed. Plugs are required for the hole(s) not being used. The photograph at the right shows two power cables, an Ethernet cable, an analog video cable, and two gland seal plugs.

If non-standard cable diameters are used, it may be necessary to locate or fabricate the appropriate insert to fit the desired cable. FLIR Systems, Inc. does not provide cable gland inserts other than what is supplied with the system.

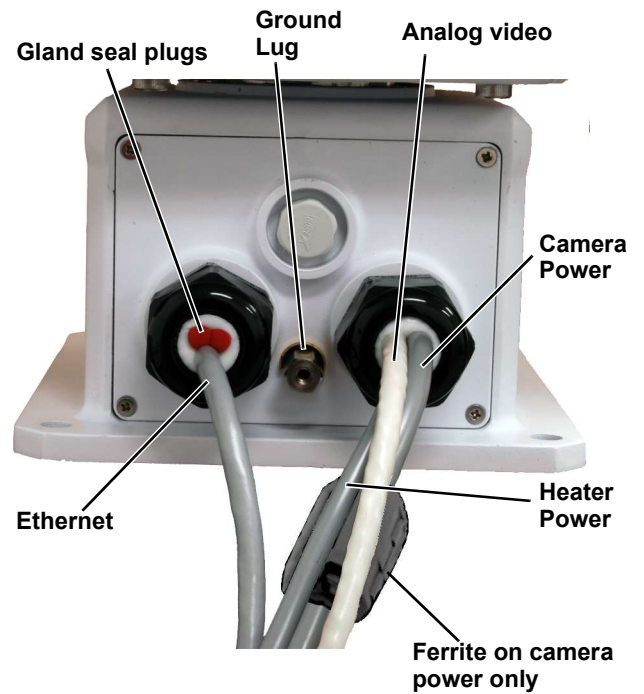

1.7 PT-Series HD Camera Specifications

<b>Uncooled Thermal Camera</b>	Array Format	640 × 512	
	Detector Type	Long-Life, Uncooled VOx Microbolometer	
	Effective Resolution	307,200 (NTSC), 327,680 (PAL)	
	Pixel Pitch	17 μm	
	Thermal Frame Rate	25 Hz / 30 Hz; 8.33 Hz video standard PAL/NTSC.	
<b>Optical Characteristics</b>	<b>Model</b>	<b>FOV</b>	<b>Focal Length</b>
	PT-606Z HD	24° HFoV to 6° HFoV	Zoom 26 mm to 105 mm, f/1.6
	PT-608 HD	8.6° × 6.6°	75 mm, f/1.1
	PT-612 HD	12° × 10°	50 mm, f/1.2
	PT-617 HD	17° × 14°	35 mm, f/1.1
	PT-625 HD	25° × 18°	25 mm, f/1.1
	PT-644 HD	44° × 36°	13 mm, f/1.0
	Continuous E-Zoom to 4x		
	Continuous optical zoom to 4x—PT-606Z HD only		
	Spectral Range 7.5 μm to 13.5 μm		
	Focus Range Athermalized, Focus-Free		
<b>Visible Camera</b>	Detector Type	1/2.8-type Exmor R CMOS, Full HD 1080p	
	Effective resolution	2,130,000 pixels	
	Field Of View	Field of view: 63.7° HFoV to 2.3° HFoV	
	Lens	30x optical zoom, 12x digital zoom 4.3 mm (wide) to 129.0 mm (narrow), F1.6 to F4.7	
<b>Cooled Thermal Camera PT-602CZ HD</b>	Array Format	640 × 480 (NTSC), 640 × 512 (PAL)	
	Detector Type	Cooled InSb MWIR Focal Plane Array	
	Spectral Range	3 μm to 5 μm	
	Thermal Sensitivity	<30 mK @ 25 °C	
	Effective Resolution	307,200 (NTSC), 327,680 (PAL)	
	Field Of View	WFOV: 28° x 22.4° (PAL) 28° x 21° (NTSC) NFOV: 2° x 1.6° (PAL) 2° x 1.5° (NTSC)	
	Optical zoom	Continuous to 14x, auto and manual focus	
	E-Zoom	Continuous E-Zoom to 4x	
<b>Compliance and Certifications</b>	EN 61000-6-4: 2007 Class A/CISPR 22: 2005 Class A		
	EN 61000-3-3: 1995+A1:2001+A2:2005		
	EN 61000-3-2: 2006		
	EN 50130-4: 1996+A1:1998+A2:2003		
	FCC Part 15, Subpart B, Class A		
	IP 66 (IEC 60529)		
	IEC 60068-2-27)		

## PT-Series HD Camera Installation

<b>Video</b>	Composite Video	NTSC or PAL Standard—switchable from <a href="#">Video</a> web page
	Video Compression	Two independent channels of streaming H.264 or M-JPEG; for each camera
	Streaming Resolution	<b>NTSC:</b> D1 (720 × 480), 4SIF (704 × 480), VGA (640 × 480), SIF (352 × 240), QVGA (320 × 240) <b>PAL:</b> D1 (720 × 576), 4CIF (704 × 576), VGA (640 × 480), CIF (352 × 288), QVGA (320 × 240)
	Thermal AGC Modes	Preset AGC modes and manual Brightness (ITT Mean), Contrast (Max Gain), Sharpness (DDE Gain), and AGC Filter controls.
	Thermal AGC Region of Interest (ROI)	Default Presets and User definable to insure optimal image quality for subjects of interest
	Image Uniformity Optimization	Automatic Flat Field Correction (FFC) with thermal and temporal triggers—Uncooled thermal camera only

<b>System Integration</b>	Ethernet	Yes
	Network Interfaces	Camera Web Server, ONVIF 2.0 Profile S, FLIR SDK, FLIR CGI Library
	Serial Control Interfaces	RS-232/-422; Pelco D, Bosch
	External Analytics Compatible	Yes
<b>Pan/Tilt</b>	Pan Angle/Speed	Continuous 360°; 0.1° to 60°/sec
	Tilt Angle/Speed	+90° to -90°; 0.1° to 30°/sec
	Programmable presets	256
<b>General</b>	Weight	Uncooled thermal camera: 36 lb (16.4 kg) Cooled thermal camera: 40.8 lb (18.5 kg)
	Dimensions (L,W,H)	13.7" × 18.4" × 12.8" (348 mm × 467 mm × 326 mm)
	Input Voltage	24 Vac (21-30 Vac); 24 Vdc (21-30 Vdc)
	Power Consumption <sup>a</sup>	Uncooled thermal camera: 24 Vac: 85 VA max w/o heaters; 215 VA with heaters 24 Vdc: 65 W max w/o heaters; 195 W with heaters Cooled thermal camera: 24 Vac: 70 VA max w/o heaters; 260 VA with heaters 24 Vdc: 60 W max w/o heaters; 203 W with heaters
<b>Environmental</b>	IP rating (dust and water ingress)	IP66
	Operating temperature range	Uncooled thermal: -40 °C to 70 °C (-40 °F to 158 °F) cold start Cooled thermal: -32°C to 55°C / -26° F to 131°F cold start
	Storage Temperature range	-55 °C to 85 °C (-67 °F to 185 °F)
	Humidity	0-95% relative
	Endurance	IEC 60068-2-64 and MIL-STD-810G, Method 514.6, Procedure 1b
	Vibration	IEC 60068-2-27, 10 g shock, 11 ms half-sine profile
	Mechanical Shock	MIL-STD-810G Transportation
	De-icing	MIL-STD-810G, Method 521.1

- a. Power consumption is independent of the input voltage when the heater is off. The power drawn by the heaters increases with the input voltage to a maximum at 30 Volts.

This chapter provides basic information on how to operate the PT-Series HD camera. A bench test can be used to verify camera operation before the camera is configured for the local network. This chapter also provides general configuration information.

## 2.1 IP Camera, ONVIF Profile S Compliant

When the camera is connected to the network it functions as a server; it provides services such as camera control, video streaming, network communications, and geo-referencing capabilities. The communications protocol used is an open, standards-based protocol that allows the server to communicate with a video management client, such as FLIR Latitude™ or with a third-party VMS client, including systems that are compatible with ONVIF Profile S. These clients can be used to control the camera and stream video during day-to-day operations. Refer to the individual product web page at [www.itm.com](#) for a listing of supported VMS clients.

### 2.1.1 Serial and/or IP Communications

For a camera that is installed in a legacy-type CCTV network using analog video, the camera may commonly be controlled with serial communications. The serial cable from the camera will be connected to a keyboard/joystick device, or to a video switch, encoder, or DVR that has a serial communication port. In this case the installer may want to configure parameters such as the address of the camera, the baud rate, and so on. These parameters can be set through software using a web browser. The parameters can also be set using DIP switches when IP communications are not used.

### 2.1.2 Server Configuration

It may be necessary for the installer to make a limited number of configuration changes to the camera server, such as setting the IP communication parameters, setting new login passwords, as well as some scene specific parameters. Many of the configuration parameters will remain unchanged from the factory default settings.

## 2.2 Camera Bench Test

Since the camera offers both analog video and IP video, the installer should test the camera using the same type of connections as the final installation. If using analog video and serial communications in the final installation, also test the IP communications when performing the bench test. If any image adjustments are necessary, they can be done using a web browser over the IP connection, and saved as power-on default settings.

When the camera is turned on, the Analog Visible Video temporarily shows the IP address of the camera web server.



**PT-602CZ HD Only**—The thermal imager is cooled by a integral Stirling cooler (also known as a cryocooler) which starts automatically when the camera is powered on. The cryocooler makes an audible noise when operating, and requires up to 8 minutes to cool the detector down to its operating temperature. When cooling down, the thermal video image shows a blue screen with the note: **Unit cooling, kindly wait.**

Test serial communications by connecting a serial device such as a keyboard and confirm the camera is responding to serial commands. It may be necessary to configure the serial device interface to operate with the camera.

Once the camera is connected to a network and powered on, set camera network parameters using the FLIR Discovery Network Assistant (DNA) software, perform a bench test by using a web browser to view the video and control the camera, or view video in the local Network Video Management System (for example, FLIR Latitude). The FLIR Discovery Network Assistant (DNA) software does not require a license to use and is a free download from the individual product web page at:

### 2.2.1 Set IP Address using the FLIR Discovery Network Assistant (DNA)

The PT-Series HD camera is shipped with Dynamic Host Configuration Protocol (DHCP) enabled to assign IP addresses. Assuming the existing network has a DHCP server, the camera will be assigned an appropriate IP address. If the network does not have a DHCP server, the PT-Series HD camera will default to 192.168.0.250. Configuring the camera for IP communications generally involves the following steps:

- Step 1 Connect the Ethernet port of the camera to the existing IP camera network.
- Step 2 Connect a PC or laptop to the same network.
- Step 3 From the PC connected to the camera network, use the DNA utility to discover and display the camera's current IP address.
  - a Download the DNA utility.
  - b Unzip the utility, then double-click to run the executable file ( DNA.exe). All the units on the VLAN are discovered.
  - c For additional instructions on using DNA, refer to the DNA User's Manual available in the Help () link while the software is running.

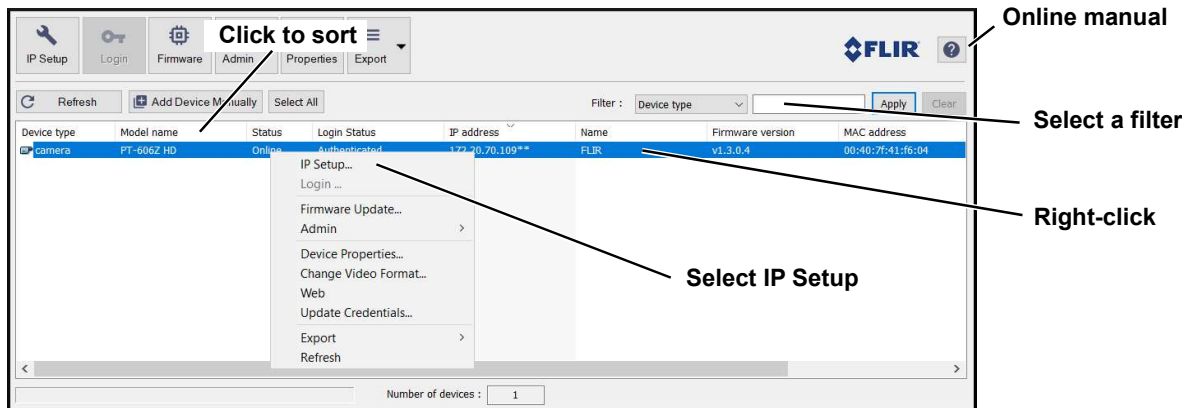

- Step 4 Select **IP Setup**  to change the IP address from the default DHCP to a static IP.
- Step 5 Double-click the camera in DNA's **Discovery List** to open the camera's web server **Login** page in a web browser, or point a web browser to the camera's IP address.
- Step 6 Using a web browser, configure the camera settings, such as camera date/time, and other parameters, so the camera is compatible with the existing network.

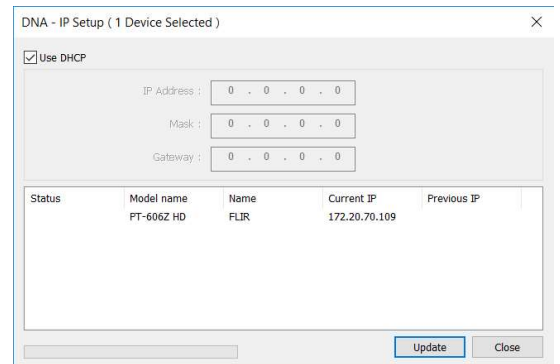

Status	Model name	Name	Current IP	Previous IP
	FT-606Z HD	FLIR	172.20.70.109	

### 2.3 Log into the Camera Web Page

Use a web browser to connect to the camera's web server using one of three User Names: **user**, **expert**, or **admin** (the default passwords are **user**, **expert**, and **admin** respectively).

#### Important Note

To prevent unauthorized access, change all of the login passwords (**admin** login required). For information on how to change the passwords, refer to [Server > Security Options, pg. 42](#).

The **user** login can be used to do the initial bench test of the camera. The **expert** login may be used to make configuration changes such as setting the IP address and other server settings. The **admin** login has access to all configuration, setup, and maintenance settings.

Two web sessions can be active at once. An inactive session will be logged out after 20 minutes.

Open a web browser — Google Chrome, Mozilla Firefox, Microsoft Internet Explorer 11, or Microsoft Edge — and enter the camera IP address. The login screen with a picture of the camera will appear. Enter **user** for the User Name and **user** for the Password, and click Log in.

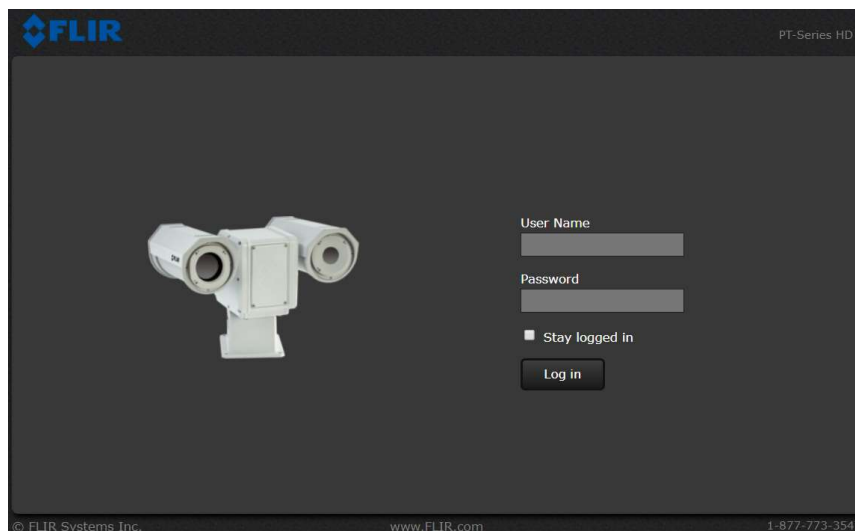

### 2.3.1 Live Video Page

The **Live Video** page displays a live image from the camera on the left part of the screen. Along the top of the screen are some menu choices, including **Live Video** (the red text indicates it is selected), **Help** and **Log out**.

On the right side are control buttons and a virtual joystick (for pan/tilt capability).



**Figure 2-1: Live Video Web Page – user login**

In the lower right corner of the web page there is a frame rate selector. This selector allows the user to change the rate at which the frames are displayed in the browser from the default 8 fps up to 16 fps. This controls the frame rate of the user's own web browser only, and does not affect the video streams to other users or to an NVR. If the live video is not displayed, refer to [Troubleshooting Tips, pg. 53](#).

#### Help

The **Help** menu displays software version information. If it is necessary to contact FLIR Technical Support for assistance, it will be helpful to have the information from this page on hand. For information about the camera including hardware part numbers and serial numbers refer to the Maintenance > Product Info > Identification web page (requires Admin login).

#### Log out

Use this button to disconnect from the camera and stop the display of the video stream. If a web session is inactive for 20 minutes, it will be stopped and it will be necessary to log in again.

#### Toggle PC/Camera time

Use this button to display either the PC time or the camera time.

### 2.3.2 Camera Control and Status

In the lower left of the screen are two indicator lights: Control and Status. Initially the Control light is off, as in the image above, indicating the user is not able to control the camera immediately. When multiple users are connected to a camera, only one user at a time can issue commands to the camera. If another user has control of the camera, the Control light is yellow.

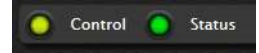

A user is able to request control of the camera by clicking on the yellow or black light, or simply by sending a command to the camera. After a short pause, the Control light should turn green. Be patient, there may be a slight delay between each command while the browser waits for a response from the camera.



If a command is sent to the camera when the user does not have control, the command will not be executed, and it is necessary to send the command again once the light is green.

### 2.3.3 Web Control Panel

The control buttons on the right side of the page can control the camera. When the mouse cursor is positioned over a button, a tool tip is displayed which explains the function of the button.

When the mouse is positioned over the video window, the video stream source is shown in the upper left corner of the video image and a snapshot button is shown in the upper right corner of the video image. The snapshot button will save an image as a .jpg file to the selected destination folder or as determined by the web browser.

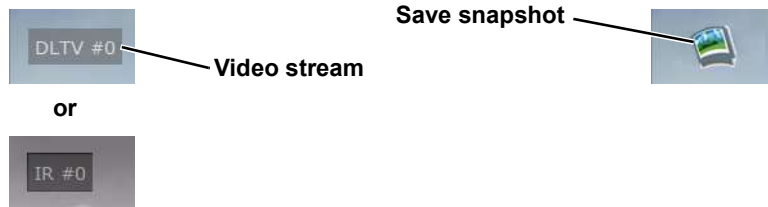

This same web interface is used with various FLIR thermal cameras, some of which have different capabilities. As a result, different buttons in the control panel will appear for different FLIR cameras.

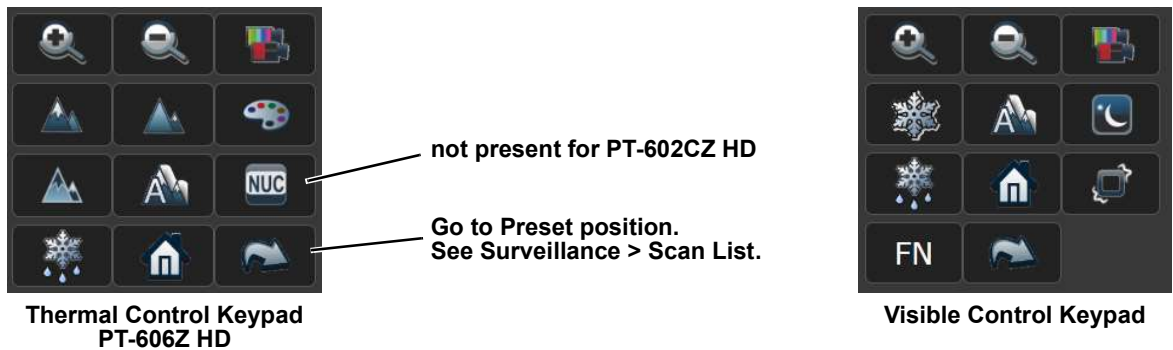

The functions of the buttons appearing for the PT-Series HD cameras are described below:



### **Zoom In/Zoom Out**

These buttons zoom the active camera (IR or daylight). On cameras with optical zoom lenses, digital zoom or E-Zoom extends the ability to zoom in beyond the optical zoom range, but at the expense of resolution. Also, refer to [“Sensor > Devices > IR > Zoom Slave”](#) on page 46.



### **Toggle Video Source**

This button causes the active video source to be switched between the thermal IR camera and the daylight camera. Refer to [“Sensor > Devices > IR > Zoom Slave”](#) on page 46.



### **Focus Near—IR only—PT-602CZ HD and PT-606Z HD only**

This button manually focuses the thermal IR lens closer to the camera. Use it to fine-tune the focus, if necessary.



### **Focus Far—IR only—PT-602CZ HD and PT-606Z HD only**

This button manually focuses the thermal IR lens further away from the camera. Use it to fine-tune the focus, if necessary.



### **Toggle Polarity—IR only**

This button changes the way various objects are displayed in the image, for example, with hot objects displayed as white and cold objects as black, or vice versa.



### **Toggle Palette—IR only**

This button causes the IR camera to cycle through different color palettes. Each of the palettes presents the IR image using a different color scheme. Use the Toggle Polarity button to invert the palette, for example, between white hot and black hot.



### **LowLight Mode On/Off—Visible only**

This button enables or disables the mode for improving the video image in low lighting conditions.



### **De-Ice On/Off—Configuration dependent**

This button manually turns the lens heaters on or off. The heaters, when turned on manually, will run for approximately one hour unless turned off either by the user (De-Ice button) or the thermostat control. Refer to [Lens Heaters](#), pg. 14.



### **Freeze Video—Visible only**

This button stops the video on a single frame. Click again to start the video.



### Autofocus

This button causes the DLTV camera to toggle the autofocus mode. Clicking the button a second time reinstates the autofocus mode and causes an autofocus operation. This button causes the IR camera with a zoom lens to perform a one-time autofocus operation.



### Perform IR NUC Calibration—IR only—not present for PT-602CZ HD

This button causes the camera to do a manual Non-Uniformity Correction (NUC) operation. The PT-Series HD camera, by default, does an automatic NUC calibration as required based on changes in temperature. The PT-602CZ HD camera (cooled) does not require a NUC operation.



### Pan/Tilt Home

This button causes the camera to go to the Home position. To set a new Home position, hold the button for approximately 3 seconds.



### Electronic Stabilization On/Off—Visible only

This button enables or disables electronic stabilization on the visible video image.



### Function—not present for PT-606Z HD

When the Function button is selected, the keypad changes to a numeric keypad. A tool tip can be shown when a function has been assigned to a number. Use the back () arrow to return to the Control Panel.



### Go to Preset

The PT-Series HD camera can have a set of predetermined pan/tilt locations, each of which is known as a preset. For example, a preset may be set for each of the locations where security surveillance is most needed, a gate, doorway, and other points of access.

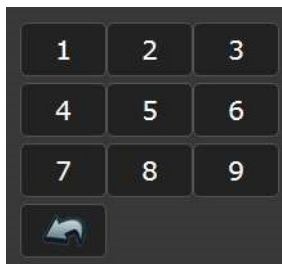

When the Go to Preset button is selected, the keypad changes to a numeric keypad.

To cause the camera to go to a predefined location view (Preset) select a number.

Use the back () arrow to return to the Control Panel.

## 2.4 Camera Configuration

The following procedures describe how to do the most common camera configuration steps, such as setting the camera IP address and hostname and changing the user passwords. To make these changes, it is necessary to log in using the **admin** account.

### Note

In most installations, the only camera settings needed are available from the Live Video page (using Scene Presets or Polarity). Use caution when modifying the camera settings described in this section. Some settings may adversely affect the thermal image over time or may completely disable the camera or the network interface.

### 2.4.1 Expert and Admin Accounts

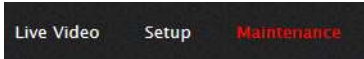

Live Video   Setup   Maintenance

When a user logs in as **expert** or **admin**, additional menus, **Setup** and **Maintenance** are available. The **Setup** menu is used to make advanced adjustments to the thermal camera, the daylight camera, and the pan/tilt platform.

The basic camera configuration steps are accessed through the **Maintenance > Server** menu, using the menus on the left side of the page. The **LAN Settings**, **Services**, and **Security Options** selections are described below ([Maintenance Menu, pg. 34](#)). The **expert** login has access to the **Server** pages. The **admin** login provides access to all configuration options. The login passwords should be changed (**admin** login required) to prevent unauthorized access.

### 2.4.2 Setup Menu

The **Setup** menu is used for GEO Settings, camera setup, and defining parameters for surveillance zones.

When configuration changes are made with the web browser, the settings are saved to a configuration file. It is a good idea to make a backup of the existing configuration file prior to making changes, and another backup once the changes are finalized. If necessary the camera can be restored to its original factory configuration or one of the saved configurations (refer to [Files > Configuration](#), pg. 50).

It is necessary to have control of the camera to make Setup changes. Changes made through the **Setup** menu have an immediate effect (it is not necessary to stop and restart the server). To use these settings at power up, it is necessary to save the changes.

Adjustments to the IR settings should only be made by someone who has expertise with thermal cameras and a thorough understanding of how the various settings affect the image. In most installations, the only camera settings needed are available from the Web Control panel on the Live Video page (Scene Presets, Polarity, Palettes, and AGC). Haphazard changes can lead to image problems including a complete loss of video.

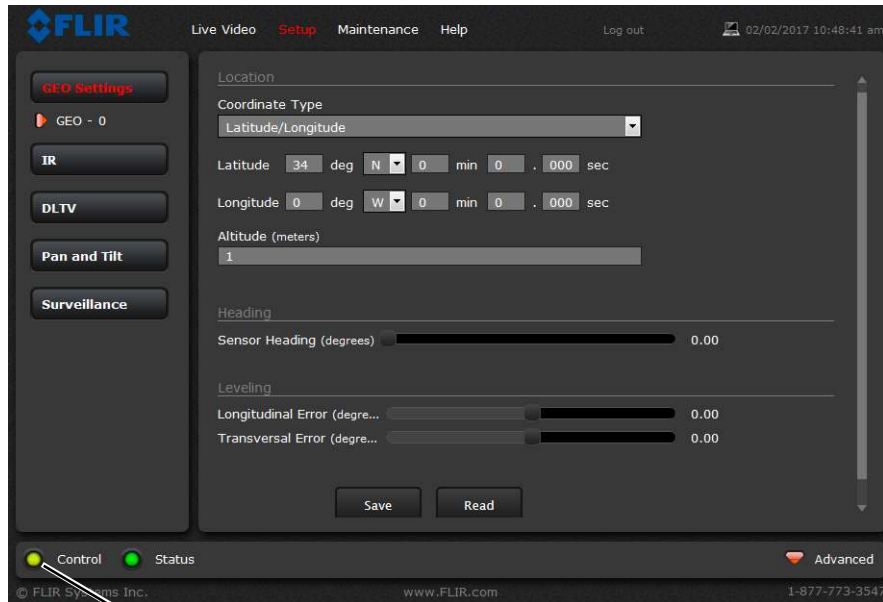

Camera Control

### Video

By default, two video streams are enabled for each camera: Video 0 and Video 1 are sourced from the DLTV camera, Video 2 and Video 3 are sourced from the IR thermal imager. All video streams are available for viewing from a client program such as FLIR Latitude, a stand-alone video player, or a third-party VMS (including ONVIF systems).

## Basic Operation and Configuration

To modify parameters that affect a particular IP Video stream from the camera, select the appropriate link (for example, **Video - 0**).

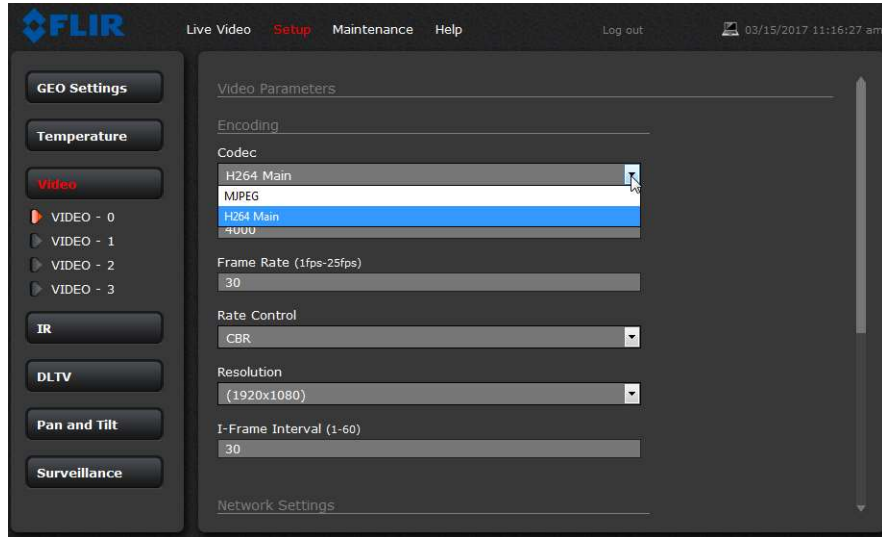

The default parameters provide high-quality full frame-rate video streams with reasonable bandwidth usage. In general, for most installations it will not be necessary to modify the default parameters. In some cases, such as when a video stream is sent over a wireless network, it may be useful to adjust the frame rate of the video stream to reduce the required bandwidth.

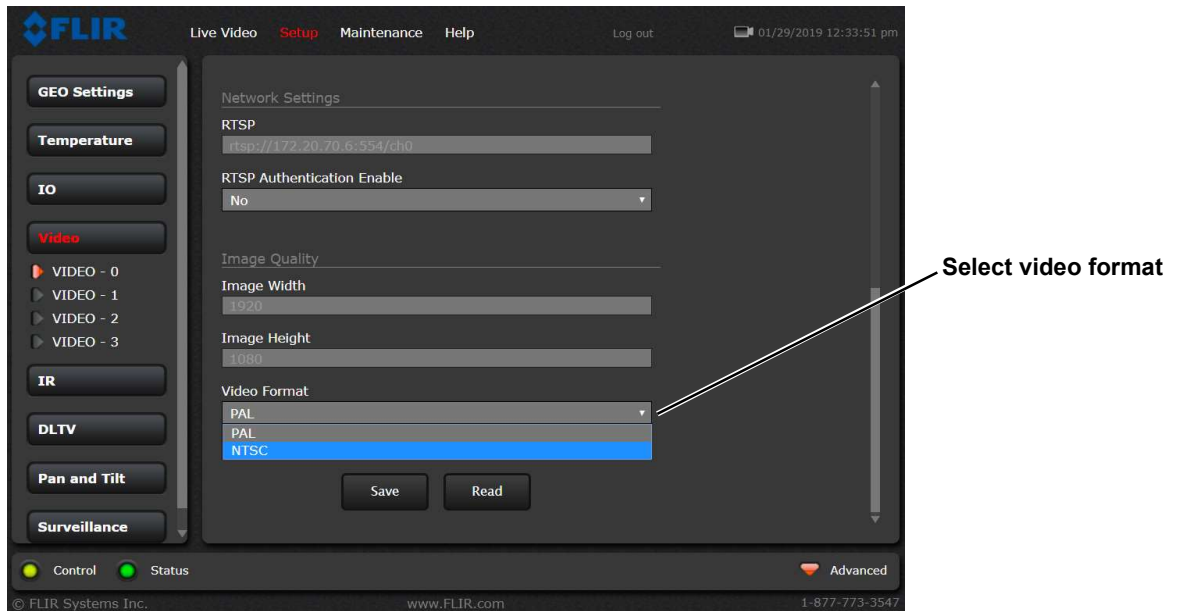

After making adjustments, scroll down to save the changes through power cycles.

The parameters in the Encoding section will have a significant impact on the quality and bandwidth requirements of the video stream. In general it is recommended that the default values are used initially, and then individual parameters can be modified and tested incrementally to determine if the bandwidth and quality requirements are met.

For the video streams, the Codec options are H.264 Main or MJPEG.

The Bit Rate parameter is only used when the Rate Control parameter is set to CBR (Constant Bit Rate). With the CBR setting, the system attempts to keep the video at or near the target bit rate.

The I-Frame Interval parameter controls the number of P-frames used between I-frames. I-frames are full frames of video and the P-frames contain the changes that occurred since the last I-frame. A smaller I-Frame Interval results in higher bandwidth (more full frames sent) and better video quality. A higher I-Frame Interval number means fewer I-frames are sent and therefore results in possibly lower bandwidth and possibly lower quality.

The Resolution parameter controls the video resolution and therefore can have a large impact on bandwidth usage. The higher the resolution, the larger the size of the frame and the higher the network bandwidth required. Table 2-1 provides the corresponding resolution for each setting.

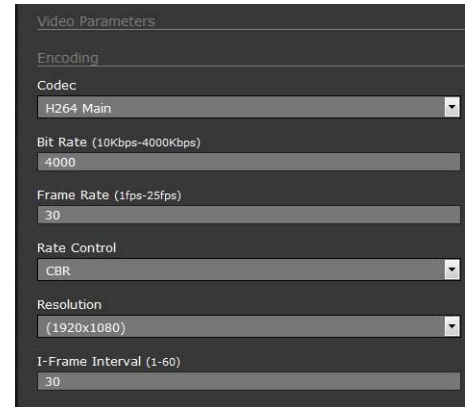

Table 2-1: Image Resolution Settings<sup>a</sup>

VIDEO - 0	<b>1920 x 1080</b> , 1280 x 720, 640 x 480
VIDEO - 1	1920 x 1080, <b>1280 x 720</b> , 720 x 480, 704 x 576, 640 x 480, 352 x 288, 320 x 240
VIDEO - 2	<b>640 x 512</b> , 320 x 256
VIDEO - 3	640 x 512, 640 x 480, 352 x 288, <b>320 x 256</b> , 320 x 240

a. Factory default resolution is shown in bold type.

If the video will be viewed on its own and on a reasonably large screen, a large image size setting may look better. On the other hand, if the video is shown as a tile in a video wall, a smaller image size may look as good and consume less bandwidth.

The default RTP Settings for connecting to an IP video stream from the PT-Series HD are shown in the illustration. The RTP Port and the Stream Name are used when establishing a session from a client.

The connection string for each of the video streams are as follows:

VIDEO 0 - rtsp://192.168.0.250:554/stream1/sensor1  
 VIDEO 1 - rtsp://192.168.0.250:554/stream2/sensor1  
 VIDEO 2 - rtsp://192.168.0.250:554/stream1/sensor2  
 VIDEO 3 - rtsp://192.168.0.250:554/stream2/sensor2

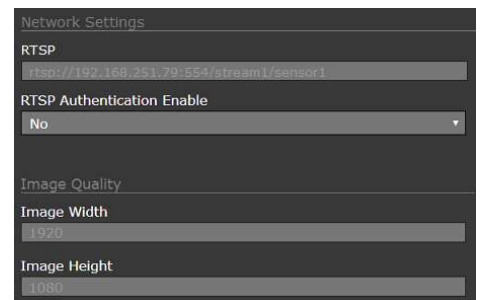

For enhanced security, RTSP authentication can be enabled.

There are some challenges with streaming video over an IP network, when compared to applications which are less time-critical, such as email and web browsing. There are requirements which must be fulfilled to ensure satisfactory video quality in professional security environments. There are many parameters and factors related to network infrastructure, protocols, codecs, and so on that can affect the quality and bit rate of a video stream when it is established between the camera and a client.

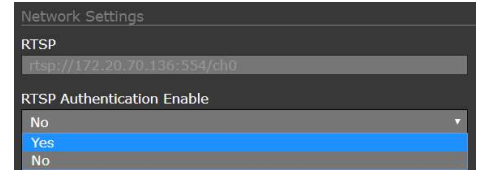

RTSP is originated and received on even port numbers and the associated RTCP communication uses the next higher odd port number; the default RTSP Port is 554.

### IR > AGC ROI

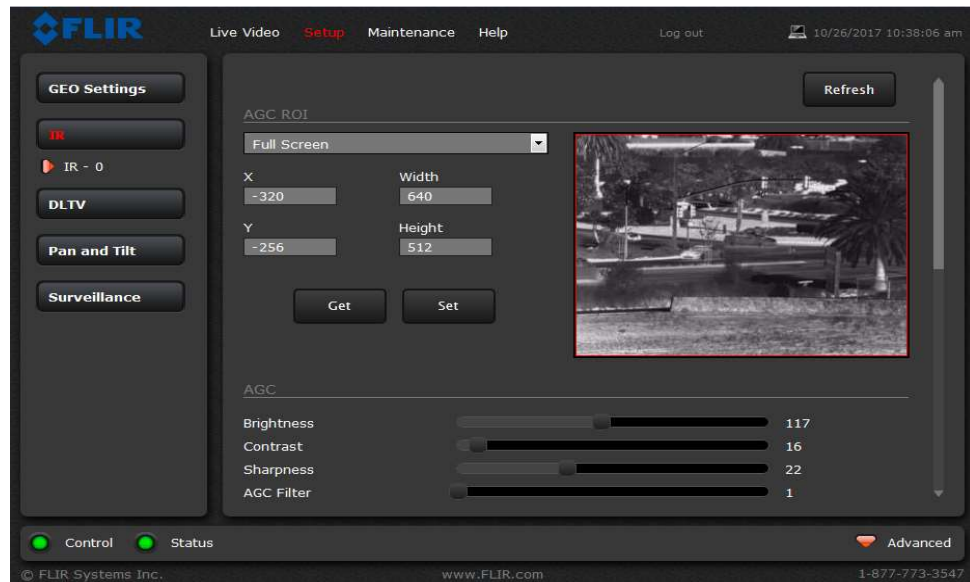

The IR camera adjustments to the region of interest (ROI) determine what portion of the image is used by the Automatic Gain Control (AGC) algorithm. By default all of the pixels in the image are considered; in some cases it may provide an improved image if a portion of the image is excluded. For example, the sky is generally very cold, so if the ROI excludes the sky it may add more contrast to the rest of the image. A pull-down list offers some convenient options.

When Custom is selected, a handle is shown in the center of the screen.

Drag the handle to set the size of the ROI box.

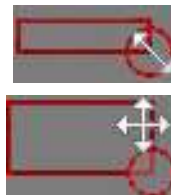

Drag the ROI box over the portion of the scene that will control the AGC.

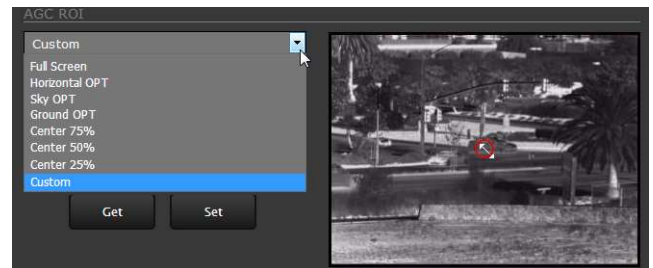

### IR > AGC

The AGC parameters affect how the overall IR video image appears. Using the AGC button on the Live Video page (refer to [LowLight Mode On/Off—Visible only, pg. 26](#)), toggle through five AGC algorithms. The default algorithms are suitable for most installations, but each selection allows a combination of further adjustments that may provide a more appealing image, depending on personal preferences. Be aware that the settings that are optimal at one time may be less optimal a short time later, since conditions such as weather and time of day affect the image and are constantly changing.

Experiment with different AGC parameters to find the settings that work best for the particular installation. Select **Save Settings** button at the bottom of the page to keep the settings after a power cycle or select the **Factory Defaults** button to return the settings to default values.

- **Brightness** (ITT Mean) setting determines the temperature that is at the middle of the 256 “shades of gray” produced by the AGC. Positive values allow more detail in hotter scenes, while negative values allow more detail in lower temperature scenes. Range is -4 to 4.
- **Contrast** (Max Gain) can be used to increase contrast, especially for scenes with little temperature variation (it may also increase noise due to increased gain). Range is 12 to 24.
- **Sharpness** (DDE Gain) is used to enhance image details and/or suppress fixed pattern noise. Positive values increase Sharpness, while negative values soften the image and filter fixed pattern noise. A setting of 0 is neutral and will not have any effect. Range is -10 to 40.
- **AGC Filter** determines how quickly a scene will adjust when a hot object appears (or disappears) within the AGC ROI. If set to a low value, when a hot object enters the ROI, the AGC will adjust more slowly to the hot object, resulting in a more gradual transition. Range is 1 to 32.

### Pan and Tilt

The screenshot shows the FLIR web interface for the 'Pan and Tilt' configuration. The top navigation bar includes 'Live Video', 'Setup', 'Maintenance', 'Help', and 'Log out'. The left sidebar has buttons for 'GEO Settings', 'IR', 'DLTV', 'Pan and Tilt' (highlighted in red), 'PT - 0', and 'Surveillance'. The main content area is titled 'Status' and contains the following fields:

Georeferenced	Azimuth	Elevation	Mode
Yes	74.2	-8	Scan List

Below this table are input fields for 'Azimuth' and 'Elevation', and a 'Go to' button. Further down, there are 'Maximum Speed' settings for 'Azimuth' (70) and 'Elevation' (70), with 'Save' and 'Read' buttons at the bottom.

Callouts in the image indicate: 'Current camera coordinates and pan/tilt mode' pointing to the table, and 'To move the camera enter coordinates, click Go to' pointing to the 'Go to' button.

The azimuth and elevation angles are measured in degrees. The elevation angle is measured from horizontal; negative values are down, positive values are up. The Azimuth angle is measured from the front of the pan/tilt unit; negative values are counter-clockwise, positive values are clockwise.

Surveillance > Scan List

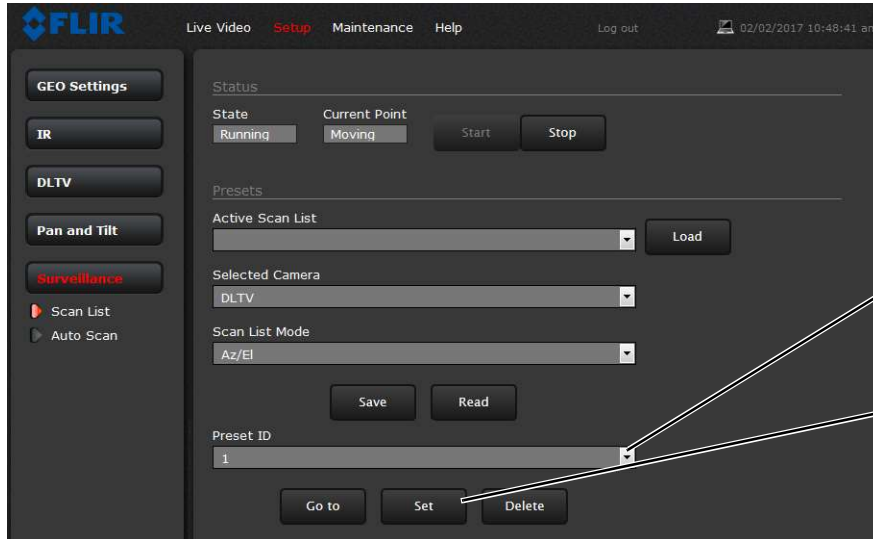

To setup Presets: position camera, select Preset ID

Click Set

Surveillance > Auto Scan

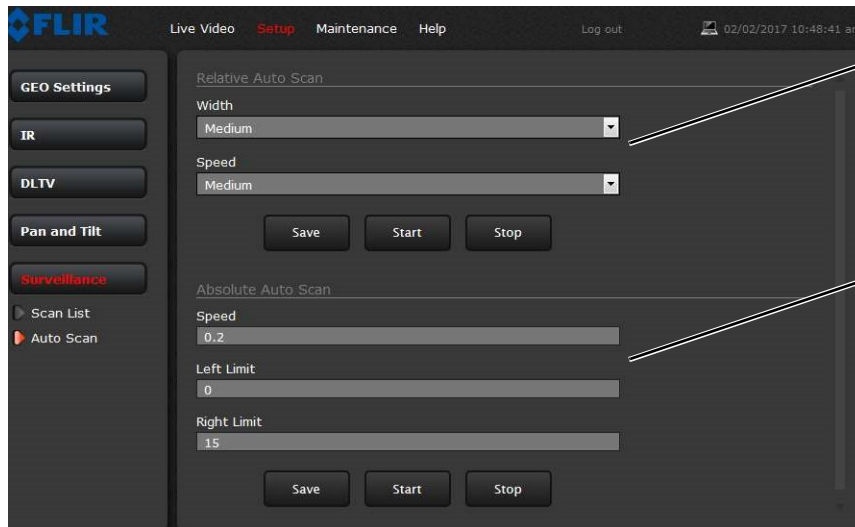

To start Auto Scan: select width and speed, then select Start

Set Autoscan parameters select speed, select limits, click Save

Relative Auto Scan (Surveillance mode) will scan the scene starting with the current position of the camera. Absolute Auto Scan will scan the scene starting with the zero azimuth position of the camera. Both can be started and the parameters set in the web page. Absolute Auto Scan can also be started as an option in the Startup mode when the camera boots. Refer to [Sensor > Devices > Pan & Tilt, pg. 47](#).

2.4.3 Maintenance Menu

When a user logs in as **admin**, a complete **Maintenance** menu is available. The basic camera configuration steps are accessed through the **Maintenance** menu, using the **Server** submenu on the left side of the page. The **LAN Settings**, **Date and Time**, **Server Status**, and **Security Options** selections are described below. Generally with these settings it is necessary to save the changes to make them effective, but it is not necessary to stop and restart the server.

### Server > LAN Settings

The **LAN Settings** page can be used to set the hostname, default gateway, and IP address for the camera. Scroll down to see settings for Domain Name System (DNS) server and 802.1x Security.

#### IP Address

When set to DHCP, if the network does not have a DHCP server, the PT-Series HD camera will default to an IP address of 192.168.0.250. To set the IP address using DNA, refer to [Set IP Address using the FLIR Discovery Network Assistant \(DNA\)](#), pg. 22.

If the IP address of the camera is changed, the PC may no longer be on the same network and therefore may not be able to access the camera until the IP address on the PC is changed also. For that reason, it may be preferable to change the IP address after making other configuration changes.

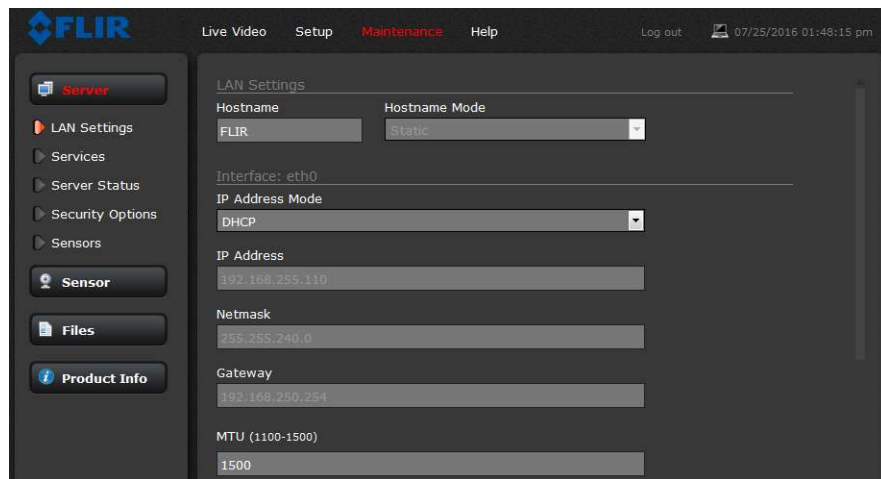

When the LAN settings are changed and the Save button is clicked, a pop-up message will appear to indicate the network interface should be restarted. Once all the changes have been made and saved, click on the **Restart Network** button at the bottom of the page.

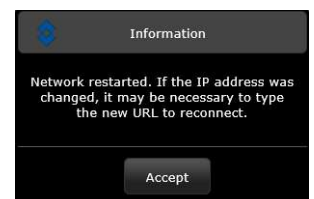

#### IEEE 802.1x Security

The IEEE 802.1x standard is designed to enhance the security of local area networks. The standard provides an authentication framework, allowing a user to be authenticated by a central authority. The PT-Series HD supports authentication using Transport Layer Security (TLS) protocol.

#### Notes

The camera must be connected to a switch or other device on the network that supports IEEE 802.1x.

The camera also supports TLS for communication with clients outside the LAN, such as web browsers. For information about enabling and configuring TLS for communication outside the LAN, see [Server > Services > TLS Config](#), pg. 39.

### To configure 802.1x security on the LAN using TLS authentication:

Step 1 On the **LAN Settings** page, scroll down to **802.1X Security**.

Step 2 Select the **Use 802.1x security** checkbox.

Step 3 From the **Authentication** drop-down menu, select **TLS**.

Step 4 In the **Identity** text box, enter a name to associate with the camera.

Step 5 If uploading a PKCS #8 certificate file, use the **Browse** and **Upload** buttons to upload the associated **CA Certificate** from the server provided by the network administrator.

If uploading a PKCS #12 certificate file, you do not need to upload a CA Certificate.

Step 6 Use the **Browse** and **Upload** buttons to upload the **Client Certificate** from the server provided by the network administrator.

Step 7 Using the **Browse** and **Upload** buttons, upload the **Private Key** associated with the identity. The **Private Key Password** field can be left blank if a password is not required.

If uploading a PKCS #8 file, the private key must be a valid PKCS #8 file.

If uploading a PKCS #12 file, the private key must be a valid PKCS #12 file.

Certificates and keys must be in PEM format. Common file extensions for TLS files in PEM format are:

- **For certificate and public key files:** \*.crt, \*.cer, \*.cert, \*.pem
- **For private key files:** \*.key

802.1X Security

Use 802.1x security

Authentication  
TLS

Identity

CA Certificate

Browse Upload

Client Certificate

Browse Upload

Private Key

Browse Upload

Private Key Password

Read Save Restart Network

### Server > Services > Date and Time

The date, time, and time zone can be obtained from an NTP server, or can be entered manually. If the NTP mode is selected, the NTP server information can be entered. The NTP server address can be entered as a static address or can be obtained via DHCP.

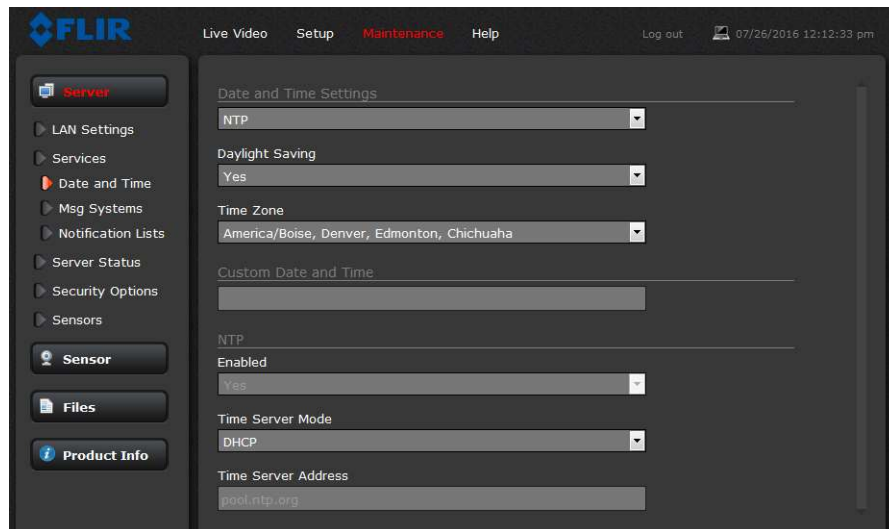

#### Note

The server must be stopped before date and time settings can be changed.

Set the date and time parameters, then select the Save button at the bottom. After saving the settings, reboot the system. Refer to [Server > Server Status](#), pg. 41.

If the Custom mode is selected, a pop-up window allows the information to be entered manually.

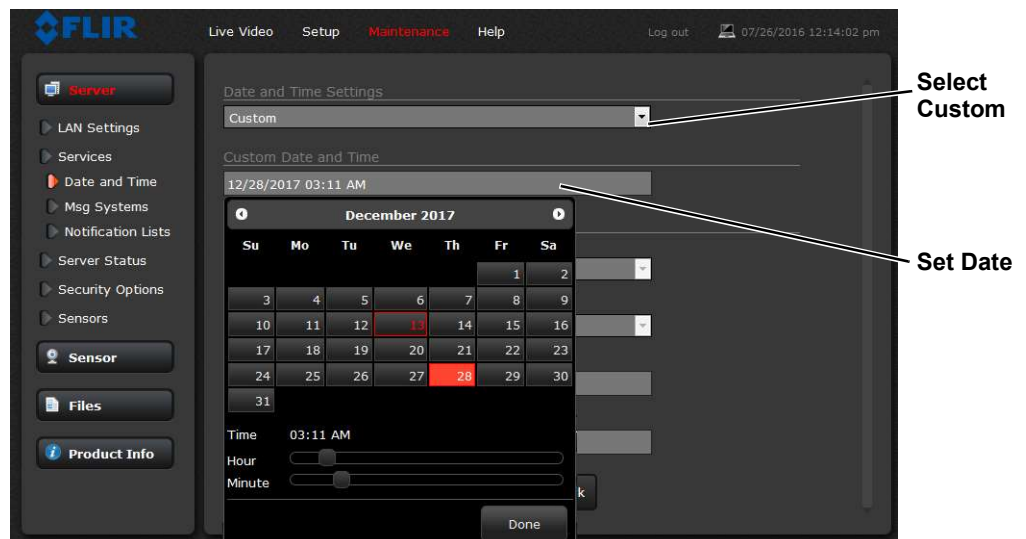

### Server > Services > Systems

Use the **Msg Systems** page to set up a connection to a mail server to send outgoing email notifications.

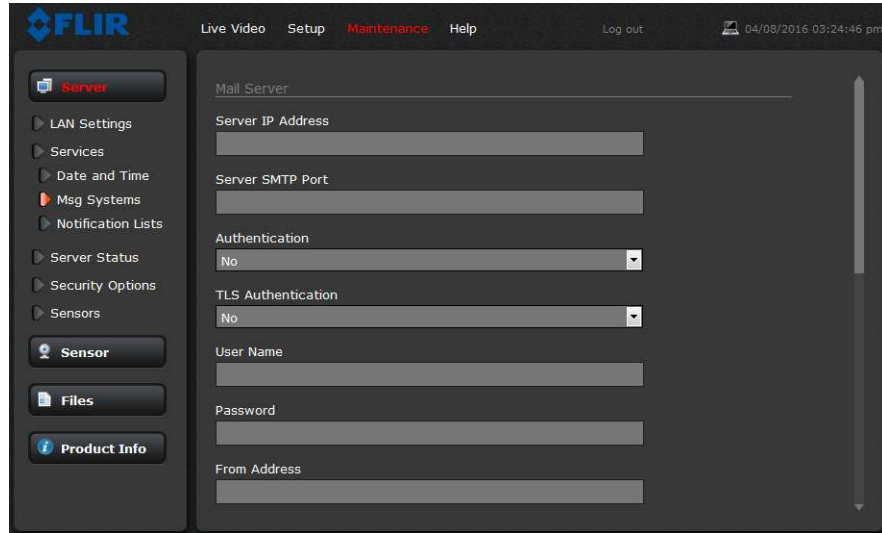

The screenshot shows the FLIR web interface with the 'Maintenance' menu selected. The left sidebar contains navigation options: Server, LAN Settings, Services, Date and Time, Msg Systems (highlighted), Notification Lists, Server Status, Security Options, Sensors, Sensor, Files, and Product Info. The main content area is titled 'Mail Server' and contains the following fields:

- Server IP Address
- Server SMTP Port
- Authentication: No
- TLS Authentication: No
- User Name
- Password
- From Address

If the email server is on a different network, ensure the IP default gateway and DNS servers are configured in the LAN Settings; refer to [Server > LAN Settings, pg. 35](#). Configure the Msg Systems page with mail server information and then click **Save**.

### Server > Services > Notification Lists

Use this page to setup multiple email addresses and other notifications that can be sent as a result of alarms being processed by the Alarm Manager.

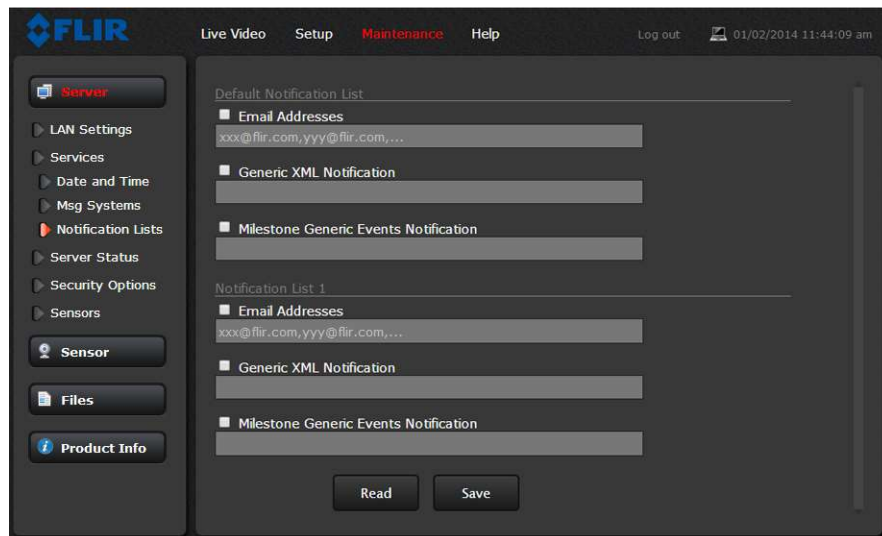

The screenshot shows the FLIR web interface with the 'Maintenance' menu selected. The left sidebar is the same as in the previous screenshot. The main content area is titled 'Default Notification List' and contains the following sections:

- Default Notification List
  - Email Addresses: xxx@flir.com, yyy@flir.com, ...
  - Generic XML Notification
  - Milestone Generic Events Notification
- Notification List 1
  - Email Addresses: xxx@flir.com, yyy@flir.com, ...
  - Generic XML Notification
  - Milestone Generic Events Notification

At the bottom of the page, there are 'Read' and 'Save' buttons.

### Server > Services > TLS Config

The settings on this page enable secure, encrypted communication between clients and the camera; for example, when your web browser accesses the camera's web interface.

#### Note

The camera also supports TLS authentication over the camera's LAN. For information about configuring TLS authentication for LAN communication, see [IEEE 802.1x Security, pg. 35](#).

By default, TLS is disabled. Before enabling it, you need to generate or upload a valid certificate. You can:

- Use the camera web interface to generate a self-signed certificate.
- Upload a self-signed certificate and a private key.
- Upload a certificate signed by a third-party, a public key, and a private key.

Certificates and keys must be in PEM format. Common file extensions for TLS files in PEM format are:

**For certificate and public key files:** \*.crt, \*.cer, \*.cert, \*.pem

**For private key files:** \*.key

From the **TLS Config** page, you can also download certificates and keys previously uploaded to or generated by the camera. If the certificate saved on the camera is self-signed, you can download the private and public key files. If the certificate was signed by a third-party CA, you can download the CA Certificate and the private and public key files.

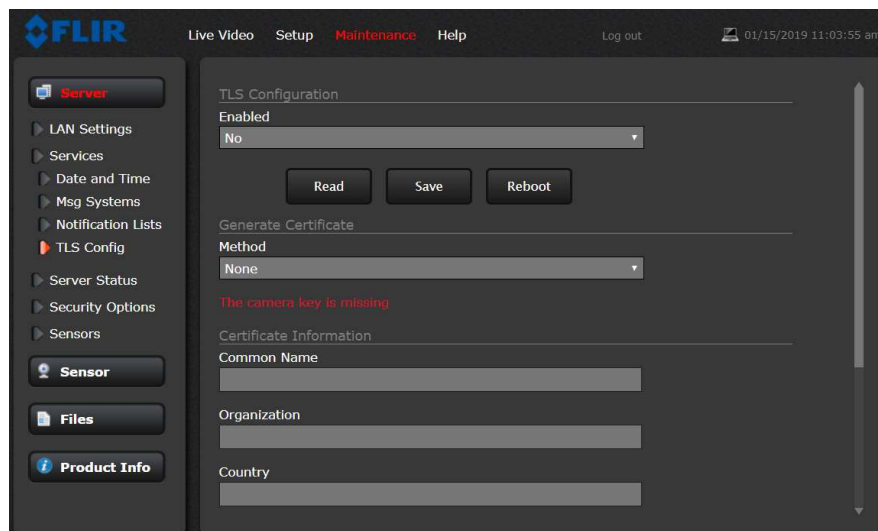

### To generate and install a self-signed certificate:

Step 1 Under Generate Certificate, for **Method**, select **Self-Signed**.

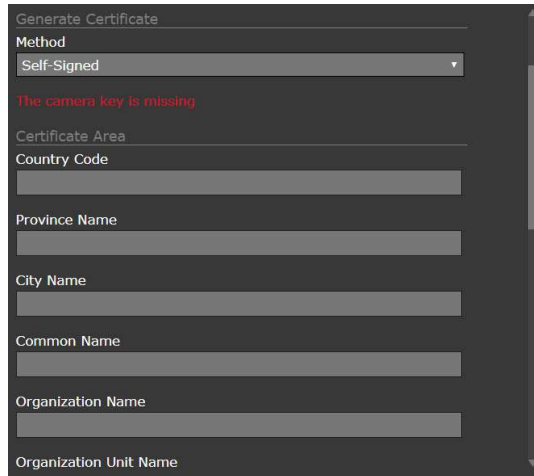

The screenshot shows a web form titled "Generate Certificate". The "Method" dropdown menu is set to "Self-Signed". Below this, there is a red error message: "The camera key is missing". The form contains several input fields: "Certificate Area", "Country Code", "Province Name", "City Name", "Common Name", "Organization Name", and "Organization Unit Name".

Step 1 Enter information such as country code, city name, and organization name.

Step 2 Scroll to the bottom of the page and click **Generate Certificate**.

Step 3 Allow 15 seconds for the camera to generate the certificate, at which point a confirmation appears.

### To upload a self-signed or third-party CA signed certificate:

Step 1 For **Method**, select **Upload Certificates**.

Step 2 If you are uploading a self-signed certificate, under **Upload Certificate**, browse for and upload the public key file. Then, under **Private Key**, browse for and upload the private key file.

If you are uploading a third-party CA signed certificate, under **Upload Certificate**, browse for and upload the public key file. Under **CA Certificate**, browse for and upload the CA certificate file. Under **Private Key**, browse for and upload the private key file.

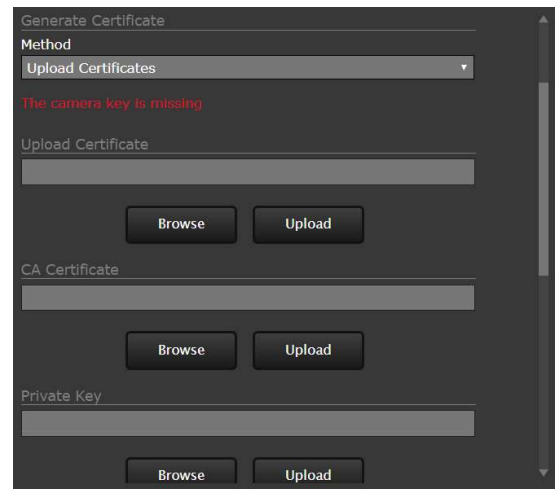

The screenshot shows the "Generate Certificate" form with the "Method" dropdown set to "Upload Certificates". There is a red error message: "The camera key is missing". The form has three sections for file uploads, each with a "Browse" and "Upload" button: "Upload Certificate", "CA Certificate", and "Private Key".

Step 3 Verify that the camera certificate files are valid. Make sure *Certificates are OK* appears under **Method**.

Certificate information appears at the bottom of the **TLS Config** page, under **Certificate Information**:

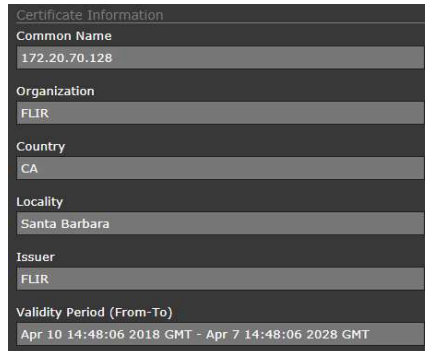

Certificate Information

Common Name	172.20.70.128
Organization	FLIR
Country	CA
Locality	Santa Barbara
Issuer	FLIR
Validity Period (From-To)	Apr 10 14:48:06 2018 GMT - Apr 7 14:48:06 2028 GMT

To enable and configure TLS:

Step 1 Under TLS Configuration, for **Enabled**, select **Yes**.

Step 2 Select whether to redirect HTTP requests to HTTPS.

Step 3 Click **Save**.

Step 4 Click **Reboot**. The camera reboots. After the camera reboots, TLS is enabled.

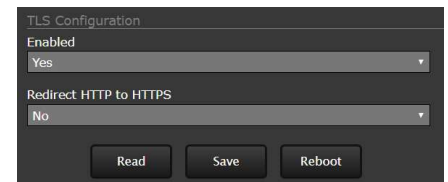

TLS Configuration

Enabled	Yes
Redirect HTTP to HTTPS	No

Read Save Reboot

### Server > Server Status

The **Server Status** page provides an indication of the current server status (either running or stopped) and buttons for starting or stopping the server and for rebooting the system. The **Uptime** section of the **Server Status** page shows how long the camera has been running, number of users, and the load on the camera processor. All values are updated only when the Server Status page is first accessed.

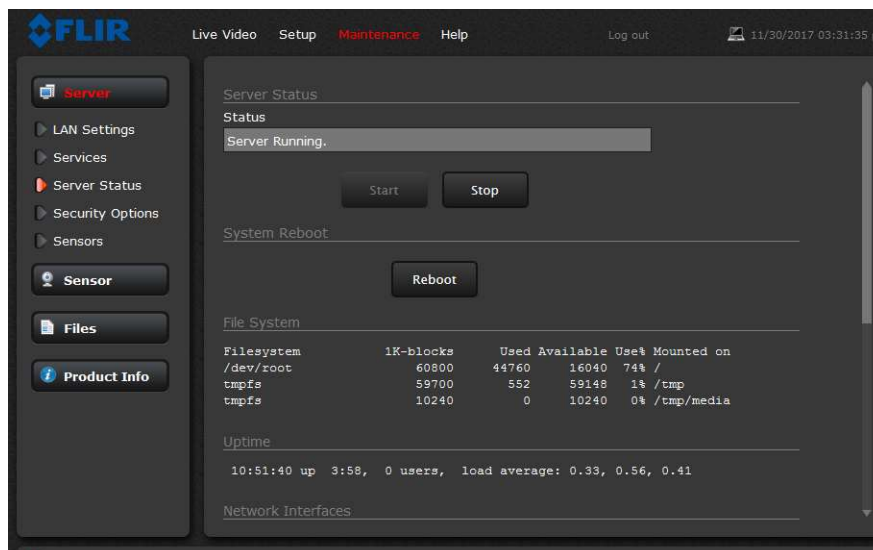

FLIR Live Video Setup Maintenance Help Log out 11/30/2017 03:31:35 pm

Server

- LAN Settings
- Services
- Server Status
- Security Options
- Sensors

Sensor

Files

Product Info

Server Status

Status

Server Running.

Start Stop

System Reboot

Reboot

File System

Filesystem	1K-blocks	Used	Available	Use%	Mounted on
/dev/root	60800	44760	16040	74%	/
tmpfs	59700	552	59148	1%	/tmp
tmpfs	10240	0	10240	0%	/tmp/media

Uptime

10:51:40 up 3:58, 0 users, load average: 0.33, 0.56, 0.41

Network Interfaces

## Basic Operation and Configuration

---

After making configuration changes, it is necessary to save the changes to the server (there is a **Save** button at the bottom of each configuration page). The configuration changes do not take effect immediately. Generally, it is also necessary to stop and restart the server for the changes to become effective. The server has a configuration that is active and running, and another configuration that is saved (and possibly different than the running configuration).

The message at the bottom of the page indicates the saved configuration is different than the active (running) configuration, and it is necessary to restart the server.



It may take up to 20 seconds or more to stop the server, especially when there are multiple video streams open. Be patient when stopping the server.

When the server is stopped and the page is refreshed, the status will show Server Stopped and the Start button will be enabled.

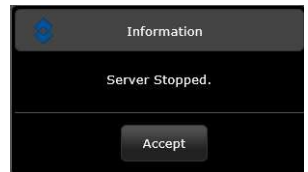

Click on the Start button to restart the server, and when the page refreshes, the status will again show Server Running. The Start button will be replaced by a Stop button when the startup procedure has completed.

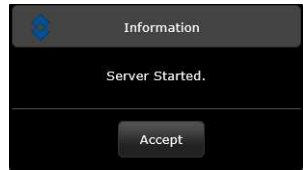

### Note

If the server unexpectedly stops, it automatically and immediately restarts. After manually stopping the server and not manually restarting it within one hour, the server automatically restarts.

### Server > Security Options

Use the **Security Options** page to enhance the camera's security by:

- Restricting access through the camera web server to specific IP addresses
- Setting or changing passwords
- Enabling the camera's firewall and enabling or disabling specific services and their ports
- Enabling Nexus CGI digest authentication

### Restrict web configuration

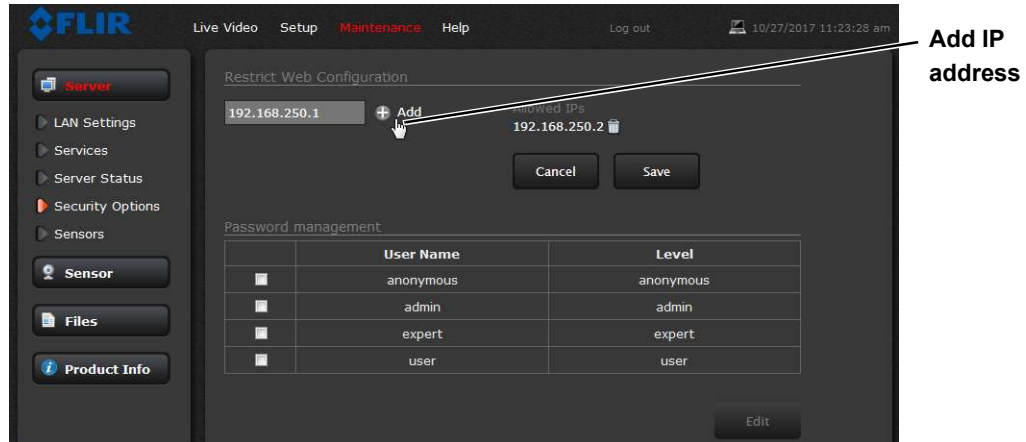

The **admin** login can limit which computers have access to the web browser interface. Simply add a computer's IP address and click Add. After all the allowed IP addresses are entered, click **Save** to save the changes.

### Password management

To maintain security of the system, set new passwords for all of the login accounts.

- **anonymous**—Used for ONVIF communication.
- **user**—The user account can only use the **Live Video** page and controls.
- **expert**—The expert account can use the **Live Video** page, the camera **Setup** page, the Server pages on the **Maintenance** menu, and set the password for the expert login.
- **admin**—The admin account can use all pages and set all passwords.

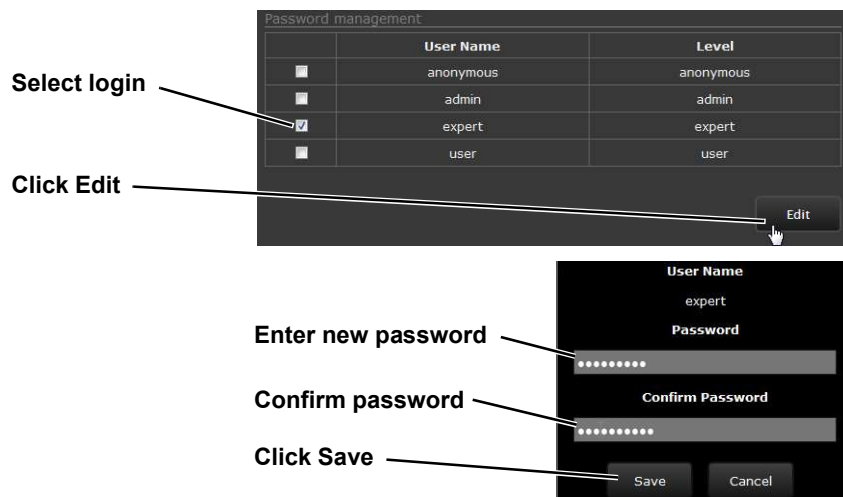

### Note

A VMS Remote to the camera, ONVIF or Nexus CGI, uses the same password as the web interface. Refer to [Sensor > Communications > VMS Remote](#), pg. 45.

### Firewall settings

For enhanced security, a firewall can be enabled (by scrolling down on the **Security Options** page).

With the firewall enabled, you can open the following services and their default ports by selecting **Enabled**:

- RTSP
- SSH
- uPnP Discovery
- Nexus SDK
- TRK Interface



#### Important Note

Disabling services can affect product functionality.

### Nexus CGI digest authentication

Below the firewall settings, you can enable Nexus CGI digest authentication.

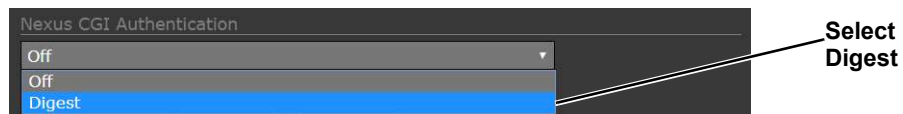

Sensor > Communications > Serial Remote

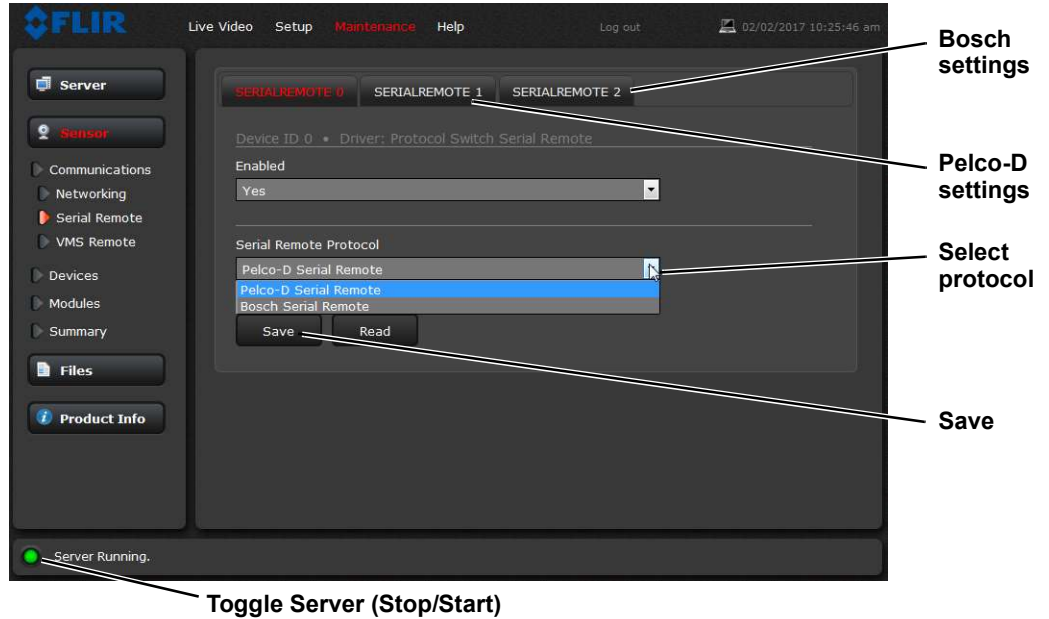

Sensor > Communications > VMS Remote

The VMS Remote page provides communication interfaces for devices that connect to the camera. Authentication when enabled uses the same passwords set from the **Server Security Options** page. Refer to [Server > Security Options, pg. 42](#).

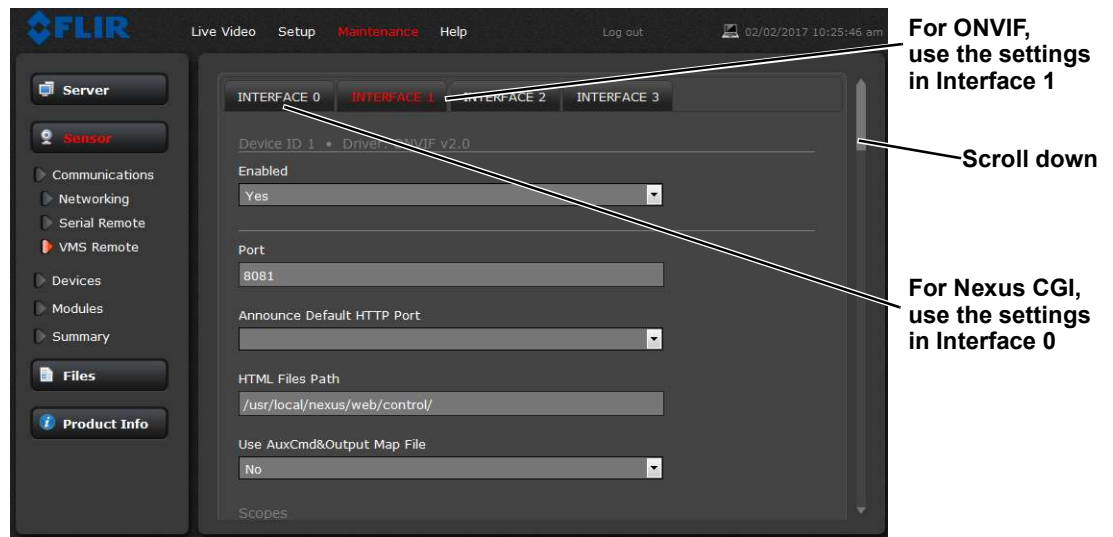

Nexus CGI Interface

After the interface is configured, scroll down and click on the **Save** button to save the configuration. The changes will not take effect until the server is stopped and started.

### ONVIF Interface

The ONVIF (Open Network Video Interface Forum) is an open industry forum for the development of a global standard for the interface of network video products. An ONVIF-compliant VMS can be used to control a FLIR camera. Refer to the VMS documentation to determine what parameters are needed. By default, the camera is configured with a VMS Remote interface with ONVIF 2.0 parameters (Profile S). After the interface is configured, scroll down and click on the **Save** button to save the configuration. The changes will not take effect until the server is stopped and started.

Several types of third-party Video Management Systems (VMS) are supported by FLIR IP cameras. Because these systems tend to evolve and change over time, contact the local FLIR representative or FLIR Technical Support to resolve any difficulties or questions about using this feature.

### Sensor > Devices > IR > Zoom Slave

The Zoom Slave function is set from the IR web page. To slave the IR camera to the DLTV zoom select the IR web page and scroll down to Zoom Slave.

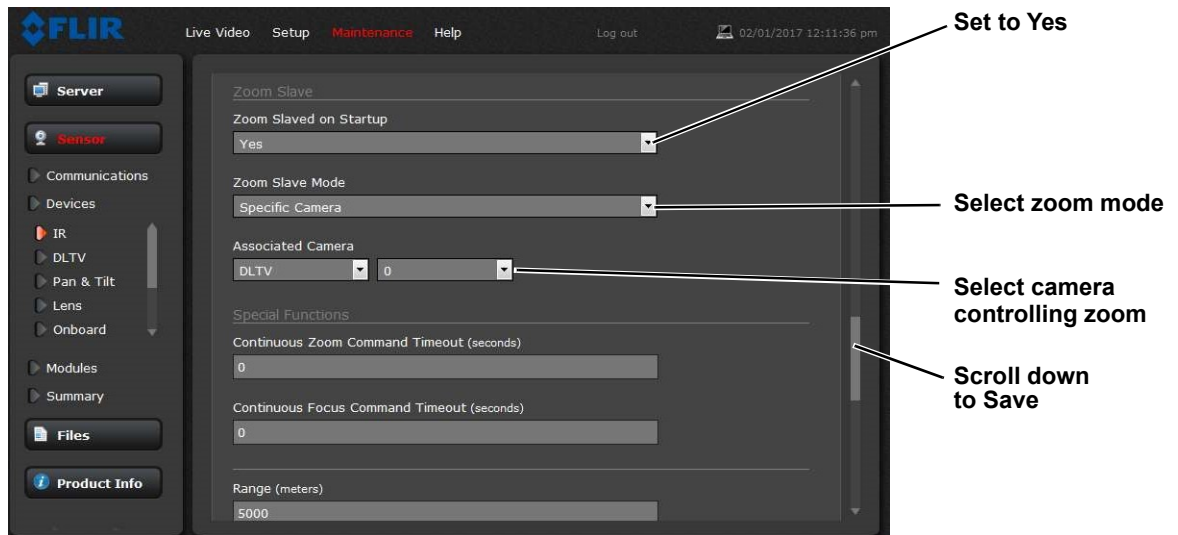

When the IR camera zoom is slaved to the DLTV camera (Specific Camera), the cameras will only zoom when the DLTV camera is the active camera.

### Sensor > Devices > Pan & Tilt

Scroll down to select an action the camera will perform at startup (power cycle or server reset).

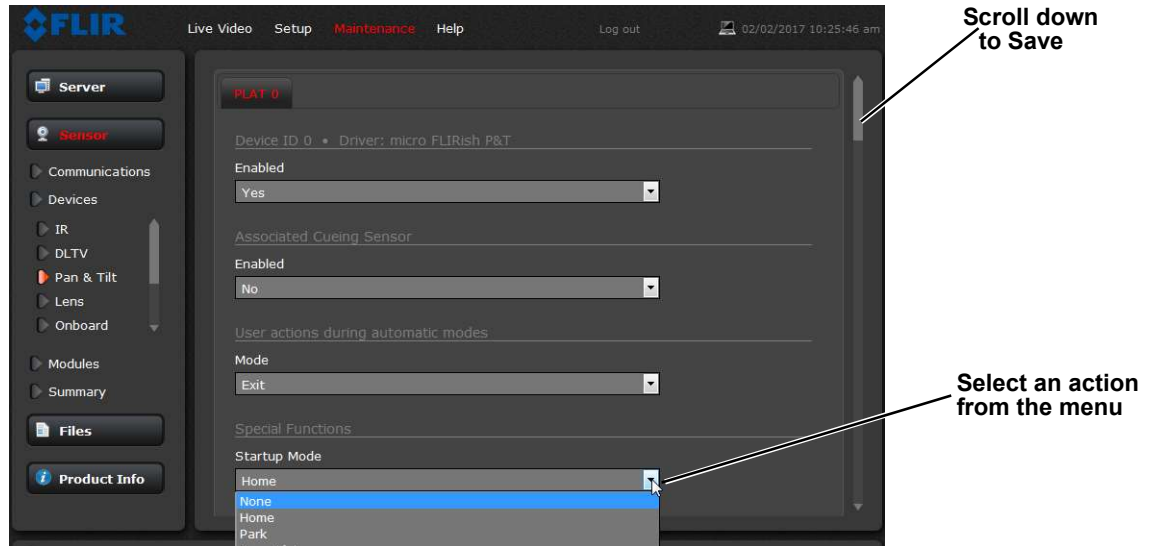

### Sensor > Modules > Video

By default, four video streams are enabled for the camera: Video 0, Video 1, Video 2, and Video 3. The streams are available for viewing from a client program such as FLIR Latitude, a stand-alone video player, or a third-party VMS including ONVIF systems. By default, Video 0 and Video 1 are from the visible camera, while Video 2 and Video 3 are from the IR sensor.

#### Caution!

Adjustments to these settings should only be made by someone trained with thermal cameras and a thorough understanding of how the various settings affect the image. Haphazard changes can lead to image problems including a complete loss of video.

To modify parameters that affect a particular IP Video stream from the camera, select the appropriate link at the top of the page (for example, **Video 0**).

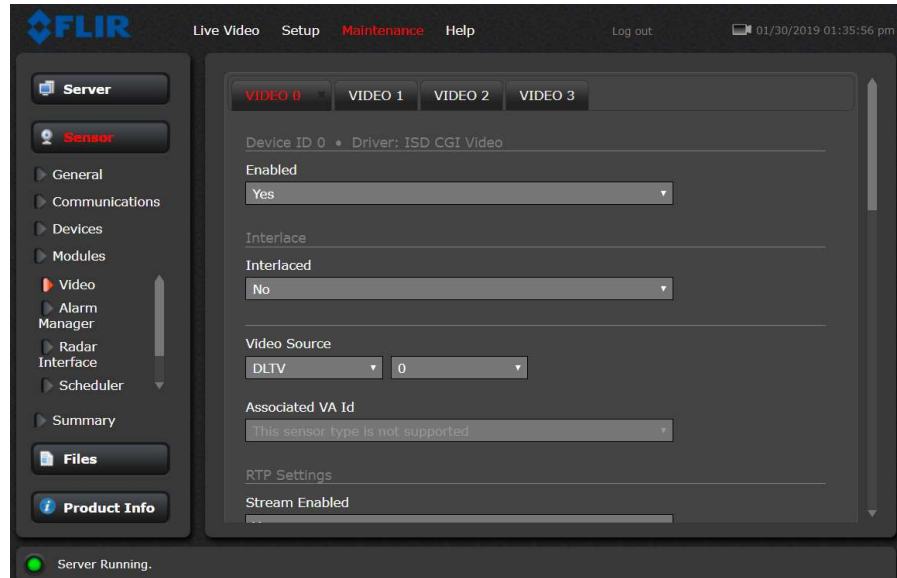

The default RTP Settings for connecting to an IP video stream from the PT-Series HD are shown in the illustration. The RTP Port and the Stream Name are used when establishing a session from a client.

Given the camera IP address of 192.168.0.250, the complete connection string for each of the video streams are as follows:  
VIDEO 0 - rtsp://192.168.0.250:554/stream1/sensor1  
VIDEO 1 - rtsp://192.168.0.250:554/stream2/sensor1  
VIDEO 2 - rtsp://192.168.0.250:554/stream1/sensor2  
VIDEO 3 - rtsp://192.168.0.250:554/stream2/sensor2

In addition, to maintain compatibility with legacy systems the stream names are aliased as: ch0 = stream1/sensor1, ch1 = stream2/sensor1, ch2 = stream1/sensor2, and ch3 = stream2/sensor2.

The video streams can be accessed with the shortened strings, such as rtsp://192.168.0.250/ch0.

In some networks, the RTP/RTSP traffic is carried (tunneled) over Hypertext Transfer Protocol (HTTP) as that may allow the traffic to cross network boundaries and firewalls. While this method involves more overhead due to encapsulation, it may be necessary for clients to access the video streams when HTTP proxies are used.

By default, the video streams from the camera are sent using multicast packets. With Multicast enabled, video packets are shared by streaming clients, so additional clients do not cause bandwidth to increase as dramatically.

If more than one camera is providing multicast streams on the network, be sure to configure each stream with a unique multicast Destination Network IP address and Destination Port combination.

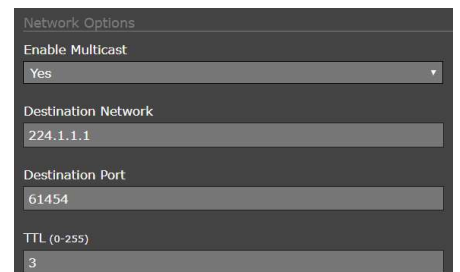

The time-to-live field controls the ability of IP packets to traverse network boundaries. A value of 1 restricts the stream to the same subnet. Greater values allow increasing access between networks.

The video streaming is done using a protocol generally referred to as Real-time Transport Protocol (RTP), but there are actually many protocols involved, including Real-Time Transport Control Protocol (RTCP) and Real Time Streaming Protocol (RTSP). In the background, a “negotiation” takes place to establish a session between the client (such as FLIR Latitude, a third party VMS, or video player) and the camera. The ports which form a session are negotiated using a protocol such as RTSP. A client typically requests a video stream using its preferred settings, and the camera can respond with its preferred settings. As a result, many of the details are established dynamically, which may run contrary to network security requirements.

The parameters in the Stream Settings section will have a significant impact on the quality and bandwidth requirements of the video stream. In general it is recommended that the default values be used initially, and then individual parameters can be modified and tested incrementally to determine if the bandwidth and quality requirements are met.

For video streams, the Codec options are H.264 and MJPEG.

The Frame Rate parameter controls the number of frames per second in the video stream.

The I-Frame Interval parameter controls the number of P-frames used between I-frames. I-frames are full frames of video and the P-frames contain the changes that occurred since the last I-frame. A smaller I-Frame Interval results in higher bandwidth (more full frames sent) and better video quality. A higher I-Frame Interval number means fewer I-frames are sent and therefore results in lower bandwidth and possibly lower quality.

When the Rate Control Type parameter is set to VBR (Variable Bit Rate), the Bit Rate parameter is used as an upper limit bit rate and the system keeps the stream at or under the target bit rate. When the Rate Control Type parameter is set to CBR (Constant Bit Rate), the Bit Rate parameter is used as a target bit rate. The system attempts to keep the bit rate of the video at or near the target.

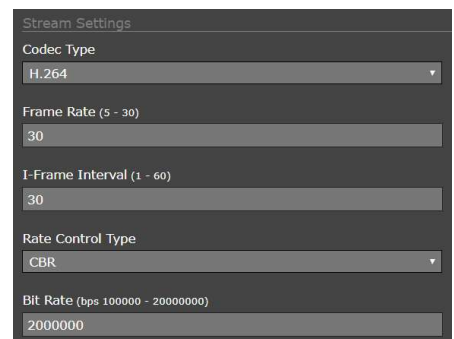

### 2.4.4 Files Menu

The administrative actions for accessing, updating, and transferring files are accessed through the **Files** menu on the left side of the page. Selected actions from the **Firmware**, **Configuration**, and **Log** pages are described below.

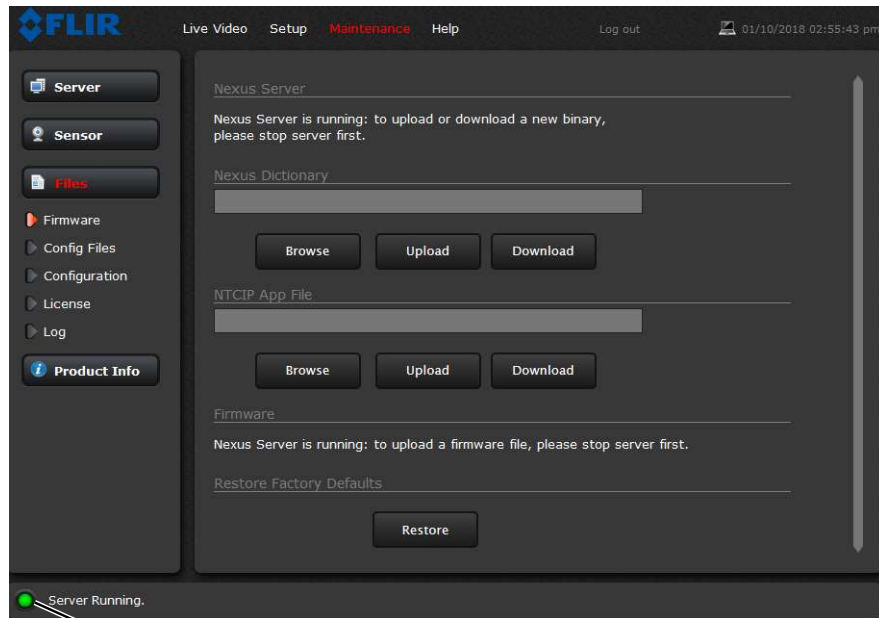

Stop server

#### Files > Firmware

For camera firmware updates, manually install a firmware update file by first stopping the camera server, browsing to select the update file on your computer, and selecting Upload. The firmware files will be uploaded and installed.

#### Caution!

The firmware update procedure resets the PT-Series HD camera to default settings. Before performing the update, detach the camera from any VMS. A firmware update resets video settings and IR settings.

#### Files > Configuration

The **Configuration** page allows the Nexus Server configuration to be displayed or backed up locally (on the camera). The configuration file can also be downloaded to another computer for backup, or a new configuration file can be uploaded from a computer to the camera. Shown at the top of the page

is the configuration script file in a scrollable window. This can be useful if help is ever needed from a support engineer.

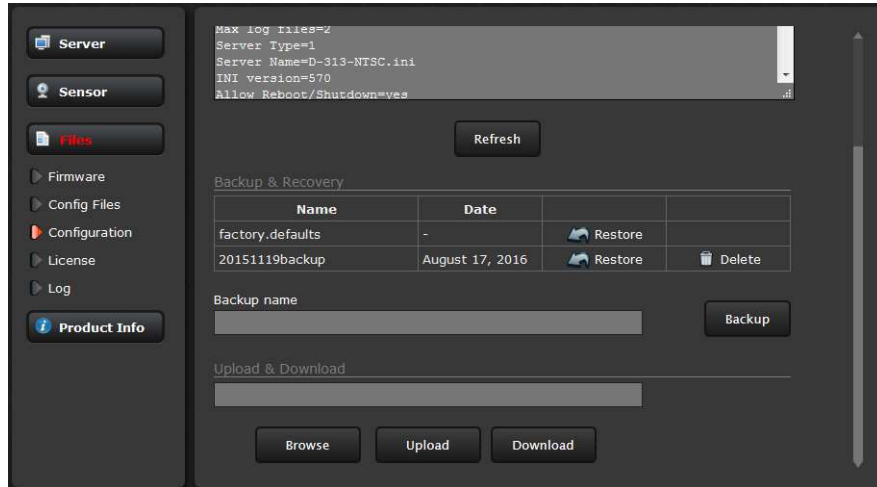

In the Backup & Recovery section, click the Restore link associated with the factory.defaults configuration to restore the camera to its factory settings. This file can not be modified or deleted, so it is always available.

Use the Backup button to make a backup of the final settings. This will make a backup copy of the configuration file and store it locally on the camera.

In the Upload & Download section, the Download Configuration File link can be used to save a copy to a PC for safe keeping. A pop-up window will ask for a file name and destination folder.

The Upload button is used to transfer a configuration file from a PC to the camera.

### Note

It is also possible to download a camera's configuration files using the following HTTP URL: <http://<ip>/configFilesGet.php>, where <ip> is the camera's IP address.

You can manually test the URL or download the files by typing the URL in a web browser.

For security reasons, you cannot download the **keys.ini** file. The download consists of all other configuration files.

### Files > Log > Field Support Log

Scroll down and select the **Download** button under Field Support Log to download a zip file to the computer for field service evaluation.

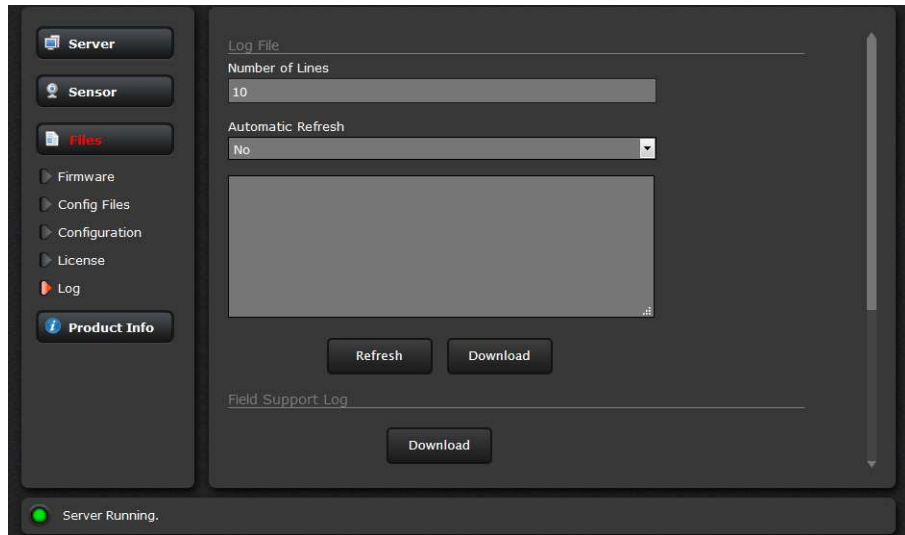

## 2.5 Thermal Imaging Overview

**PT-602CZ HD Only**—When power is applied to the PT-602CZ HD camera, a compact integral Stirling cooler (also known as a cryocooler) starts automatically. The cryocooler makes an audible noise when it is operating, and requires up to 8 minutes to cool the thermal imager down to its operating temperature. When cooling down, the thermal video image shows a blue screen with the note:

**Unit cooling, kindly wait.**

The thermal camera makes an image based on temperature differences. In the thermal image, by default the hottest item in the scene appears as white and the coldest item is black, and all other items are represented as a gray scale value between white and black.

It may take some time to get used to the thermal imagery from the camera, especially for someone who only has experience with normal daylight cameras. Having a basic understanding of the differences between thermal and daylight cameras can help with getting the best performance from the thermal camera.

Both thermal and daylight cameras have detectors (pixels) that detect energy. One difference between thermal and daylight cameras has to do with where the energy comes from to create an image. When viewing an image with an ordinary camera, there has to be some source of visible light (something hot, such as the sun or lights) that reflects off the objects in the scene to the camera. The same is true with human eyesight; the vast majority of what people see is based on **reflected** light energy.

On the other hand, the thermal camera detects energy that is directly **radiated** from objects in the scene. Most objects in typical surroundings are not hot enough to radiate visible light, but they easily radiate the type of infrared energy that the thermal camera can detect. Even very cold objects, like ice and snow, radiate this type of energy.

The camera is capable of sensing very small temperature differences, and produces a video image that typically has dramatic contrast in comparison to daylight cameras. This high contrast level from the thermal video enables intelligent video analytic software to perform more reliably.



The performance of the camera varies throughout the day. Right after sunset, objects warmed by the sun will appear warmest. Early in the morning, many of these objects will appear cooler than their surroundings, so be sure to look for subtle differences in the scene, as opposed to just hot targets.

While the imagery on the monitor may at first look similar to ordinary black and white daylight video, experience with the camera in varying conditions and seasons will lead to an appreciation of the characteristics that make thermal imaging distinct. A few tips on how to interpret some of the imagery may help to make the most of the system.

The camera senses small differences in apparent radiation from the objects in view, and displays them as either white (or lighter shades of gray) for warmer objects, and black (or darker shades of gray) for colder objects. This is why hot objects such as parts on an engine and exhaust pipes appear white, while the sky, puddles of water and other cold objects appear dark (or cool). Scenes with familiar objects will be easy to interpret with some experience. The camera automatically optimizes the image to provide the best contrast in most conditions.

### 2.6 Troubleshooting Tips

If help is needed during the installation process, contact your local FLIR representative. FLIR Systems, Inc. offers a selection of training courses to help get the best performance and value from your thermal imaging camera.

Find out more at the FLIR training web page:

**No video:** Check the video connection at the camera and at the display. If the connectors appear to be properly connected but the camera still does not produce an image, ensure that power has been properly applied to the camera and the circuit breaker is set properly. If a fuse was used, be sure the fuse is not blown. If the video cabling is suspected as a possible source of the problem, plug a monitor into the RCA connection inside the camera and determine if it produces an image.

If the camera still does not produce an image, contact the FLIR dealer or reseller who provided the camera, or contact FLIR directly (contact information is provided on the rear cover of this manual).

**Performance varies with time of day:** It may be possible to observe differences in the way the camera performs at different times of the day, due to the diurnal cycle of the sun. Recall that the camera produces an image based on temperature differences.

At certain times of the day, such as just before dawn, the objects in the image scene may all be roughly the same temperature, compared to other times of the day. Compare this to imagery right after sunset, when objects in the image may be radiating heat energy that has been absorbed during

the day due to solar loading. Greater temperature differences in the scene generally will allow the camera to produce higher-contrast imagery.

Performance may also be affected when objects in the scene are wet rather than dry, such as on a foggy day or in the early morning when everything may be coated with dew. Under these conditions, it may be difficult for the camera to show the temperature the object itself, rather than of the water coating.

**Unable To Communicate Over Ethernet:** First check to ensure the physical connections are intact and that the camera is powered on and providing analog video to the monitor. When the camera is turned on, confirm the camera IP address is shown on the Analog Visible Video monitor after approximately 90 seconds.

Confirm that the IP address for the PC is on the same network as the camera.

By default the camera will broadcast a discovery packet two times per second. Use the FLIR Discovery Network Assistant (DNA) or a packet sniffer utility such as Wireshark and confirm the packets are being received by the PC from the camera.

Determine if Windows Personal Firewall is blocking the packets. Turn off the firewall or add an exception for the client program. Typically when a program runs for the first time, a pop-up notification may ask for permission to communicate on the network. Select the check boxes (domain/private/public) that are appropriate for the network.

**Unable to View Video Stream:** If the video stream from the camera is not displayed in a client program, it could be that the packets are blocked by the firewall, or there could be a conflict with video codecs that are installed for other video programs.

When displaying video with FLIR Latitude or a VMS for the first time, the Windows Personal Firewall may ask for permission to allow the video player to communicate on the network. Select the check boxes (domain/private/public) that are appropriate for the network.

If necessary, test to make sure the video from the camera can be viewed by a generic video player such as VLC media player ( ). To view the video stream, specify RTSP port 554 and the appropriate stream name. For example:  
rtsp://192.168.0.250:554/stream1/sensor2.

In addition, to maintain compatibility with legacy systems the stream names are aliased as: ch0 = stream1/sensor1, ch1 = stream2/sensor1, ch2 = stream1/sensor2, and ch3 = stream2/sensor2.

The video streams can be accessed with the shortened strings, such as rtsp://192.168.0.250/ch0.

Refer to [Sensor > Modules > Video](#), pg. 47.

**Noisy image:** A noisy image is usually attributed to a cable problem (too long or inferior quality) or the cable is picking up electromagnetic interference (EMI) from another device. Although coax cable has built-in losses, the longer the cable, or the smaller the wire gauge, the more severe the losses become; and the higher the signal frequency, the more pronounced the losses. Unfortunately this is one of the most common and unnecessary problems that plagues video systems in general.

Cable characteristics are determined by a number of factors (core material, dielectric material and shield construction, among others) and must be carefully matched to the specific application. Moreover, the transmission characteristics of the cable will be influenced by the physical environment through which the cable is run and the method of installation.

Check cable connector terminations. Inferior quality connections may use multiple adapters which can cause unacceptable noise. Use a high-quality video distribution amplifier when splitting the signal to multiple monitors.

**Image too dark or too light:** By default the PT-Series HD thermal camera uses an Automatic Gain Control (AGC) setting that has proven to be superior for most applications, and the camera will respond to varying conditions automatically. The installer should keep in mind that the sky is quite cold and can strongly affect the overall image. It may be possible to avoid a problem by slightly moving the camera up or down to include (or exclude) items with hot or cold temperatures that influence the overall image. For example, a very cold background (such as the sky) could cause the camera to use a wider temperature range than appropriate.

**Eastern or Western Exposure:** Once installed, the camera may point directly east or west, and this may cause the sun to be in the field of view during certain portions of the day. We do not recommend intentionally viewing the sun, but looking at the sun will not permanently damage the sensor. The thermal imaging camera often provides a considerable advantage over a visible camera in a back-lit situation. However, the sun may introduce image artifacts that eventually will be corrected but it may take some time to recover. The amount of time needed will depend on how long the camera was exposed to the sun. The longer the exposure, the longer the recovery time needed.



visible camera



thermal camera

Figure 2-2: Images facing sun

# 3

## Serial Address: Decimal To Binary Conversion

Note, the order of the switches 1-8 is the reverse of the binary digits. For example, for address 1 the binary equivalent is 00000001 and the left-most switch (switch1) is on.

### 3.1 Address Conversion Table

Address	Sw1	Sw 2	Sw 3	Sw4	Sw 5	Sw 6	Sw 7	Sw 8
1	ON	OFF	OFF	OFF	OFF	OFF	OFF	OFF
2	OFF	ON	OFF	OFF	OFF	OFF	OFF	OFF
3	ON	ON	OFF	OFF	OFF	OFF	OFF	OFF
...	...	...	...	...	...	...	...	...
255	ON	ON	ON	ON	ON	ON	ON	ON

The following table shows the binary equivalent for each decimal address between 1 and 255.

Decimal	Binary	Decimal	Binary	Decimal	Binary	Decimal	Binary
1	00000001	65	01000001	129	10000001	193	11000001
2	00000010	66	01000010	130	10000010	194	11000010
3	00000011	67	01000011	131	10000011	195	11000011
4	00000100	68	01000100	132	10000100	196	11000100
5	00000101	69	01000101	133	10000101	197	11000101
6	00000110	70	01000110	134	10000110	198	11000110
7	00000111	71	01000111	135	10000111	199	11000111
8	00001000	72	01001000	136	10001000	200	11001000
9	00001001	73	01001001	137	10001001	201	11001001
10	00001010	74	01001010	138	10001010	202	11001010
11	00001011	75	01001011	139	10001011	203	11001011
12	00001100	76	01001100	140	10001100	204	11001100
13	00001101	77	01001101	141	10001101	205	11001101
14	00001110	78	01001110	142	10001110	206	11001110
15	00001111	79	01001111	143	10001111	207	11001111
16	00010000	80	01010000	144	10010000	208	11010000
17	00010001	81	01010001	145	10010001	209	11010001
18	00010010	82	01010010	146	10010010	210	11010010
19	00010011	83	01010011	147	10010011	211	11010011
20	00010100	84	01010100	148	10010100	212	11010100
21	00010101	85	01010101	149	10010101	213	11010101
22	00010110	86	01010110	150	10010110	214	11010110
23	00010111	87	01010111	151	10010111	215	11010111
24	00011000	88	01011000	152	10011000	216	11011000
25	00011001	89	01011001	153	10011001	217	11011001
26	00011010	90	01011010	154	10011010	218	11011010

## Serial Address: Decimal To Binary Conversion

27	00011011	91	01011011	155	10011011	219	11011011
28	00011100	92	01011100	156	10011100	220	11011100
29	00011101	93	01011101	157	10011101	221	11011101
30	00011110	94	01011110	158	10011110	222	11011110
31	00011111	95	01011111	159	10011111	223	11011111
32	00100000	96	01100000	160	10100000	224	11100000
33	00100001	97	01100001	161	10100001	225	11100001
34	00100010	98	01100010	162	10100010	226	11100010
35	00100011	99	01100011	163	10100011	227	11100011
36	00100100	100	01100100	164	10100100	228	11100100
37	00100101	101	01100101	165	10100101	229	11100101
38	00100110	102	01100110	166	10100110	230	11100110
39	00100111	103	01100111	167	10100111	231	11100111
40	00101000	104	01101000	168	10101000	232	11101000
41	00101001	105	01101001	169	10101001	233	11101001
42	00101010	106	01101010	170	10101010	234	11101010
43	00101011	107	01101011	171	10101011	235	11101011
44	00101100	108	01101100	172	10101100	236	11101100
45	00101101	109	01101101	173	10101101	237	11101101
46	00101110	110	01101110	174	10101110	238	11101110
47	00101111	111	01101111	175	10101111	239	11101111
48	00110000	112	01110000	176	10110000	240	11110000
49	00110001	113	01110001	177	10110001	241	11110001
50	00110010	114	01110010	178	10110010	242	11110010
51	00110011	115	01110011	179	10110011	243	11110011
52	00110100	116	01110100	180	10110100	244	11110100
53	00110101	117	01110101	181	10110101	245	11110101
54	00110110	118	01110110	182	10110110	246	11110110
55	00110111	119	01110111	183	10110111	247	11110111
56	00111000	120	01111000	184	10111000	248	11111000
57	00111001	121	01111001	185	10111001	249	11111001
58	00111010	122	01111010	186	10111010	250	11111010
59	00111011	123	01111011	187	10111011	251	11111011
60	00111100	124	01111100	188	10111100	252	11111100
61	00111101	125	01111101	189	10111101	253	11111101
62	00111110	126	01111110	190	10111110	254	11111110
63	00111111	127	01111111	191	10111111	255	11111111
64	01000000	128	10000000	192	11000000		