

KJ-2200/KJ-3100 Water Jetting Machines



⚠ WARNING!

Read this Operator's Manual carefully before using this tool. Failure to understand and follow the contents of this manual may result in electrical shock, fire and/or serious personal injury.

Table of Contents

- Recording Form For Machine Serial Number** 1
- Safety Symbols** 2
- General Safety Rules**
 - Work Area Safety 2
 - Electrical Safety 2
 - Personal Safety 2
 - Tool Use and Care 2
 - Service 3
- Water Jetter Safety Warnings** 3
- Description, Specifications and Standard Equipment**
 - Description 4
 - Specifications 4
 - Icons 5
 - Standard Equipment 5
- Machine Assembly**
 - Engine Oil 5
 - Pump/Gearbox Oil 5
 - KJ-2000 Transport Cart 5
 - KJ-3100 Handle Assembly 5
- Pre-Operation Inspection** 6
- Machine and Work Area Set Up** 7
 - Water Supply 8
 - Drain Preparation 9
 - Hose Set-Up 9
 - Jetter Hose Selection Chart 10
 - Jetter Nozzle Selection Chart 10
- Operating Instructions** 11
 - Jetting The Drain 12
 - Using The Pulse Mode 13
 - Using Water Jetter Machine as a Pressure Washer 13
 - Pressure Washer Operation 14
 - Detergent Injector 14
- Maintenance Instructions**
 - Cleaning 14
 - Engine 15
 - Pump Lubrication 15
 - Gearbox Lubrication 15
 - Preparing Pump for Cold Weather Storage 15
- Accessories** 15
- Machine Storage** 16
- Service And Repair** 16
- Disposal** 16
- Troubleshooting** 17
- Lifetime Warranty** Back Cover

*Original Instructions - English

Water Jetter

KJ-2200/KJ-3100 Water Jetting Machines



RIDGID[®]

KJ-2200/KJ-3100 Water Jetting Machines

Record Serial Number below and retain product serial number which is located on nameplate.

Serial
No.

--	--

Safety Symbols

In this operator's manual and on the product, safety symbols and signal words are used to communicate important safety information. This section is provided to improve understanding of these signal words and symbols.

This is the safety alert symbol. It is used to alert you to potential personal injury hazards. Obey all safety messages that follow this symbol to avoid possible injury or death.

DANGER DANGER indicates a hazardous situation which, if not avoided, will result in death or serious injury.

WARNING WARNING indicates a hazardous situation which, if not avoided, could result in death or serious injury.

CAUTION CAUTION indicates a hazardous situation which, if not avoided, could result in minor or moderate injury.

NOTICE NOTICE indicates information that relates to the protection of property.



This symbol means read the operator's manual carefully before using the equipment to reduce the risk of injury. The operator's manual contains important information on the safe and proper operation of the equipment.



This symbol means always wear safety glasses with side shields or goggles when handling or using this equipment to reduce the risk of eye injury.



This symbol indicates the risk of high pressure water directed at body parts, causing skin puncture and injection injuries.



This symbol indicates the risk of the jetter hose whipping, and causing striking or injection injuries.



This symbol indicates the risk of breathing carbon monoxide and causing nausea, fainting or death.



This symbol indicates the risk of fire and explosion from gasoline or other sources causing burns and other injury.

General Safety Rules

WARNING

Read and understand all instructions. Failure to follow all instructions listed below may result in electric shock, fire, and/or serious injury.

SAVE THESE INSTRUCTIONS!

Work Area Safety

- **Keep work area clean and well lit.** Cluttered benches and dark areas invite accidents.
- **Do not operate power tools in explosive atmospheres, such as in the presence of flammable liquids, gases, or dust.** Power tools create sparks which may ignite the dust or fumes.
- **Keep bystanders, children, and visitors away while operating a power tool.** Distractions can cause you to lose control.

Electrical Safety

- **Avoid body contact with grounded surfaces such as pipes, radiators, ranges and refrigerators.** There is an increased risk of electric shock if your body is grounded.

Personal Safety

- **Stay alert, watch what you are doing and use common sense when operating a power tool. Do not use a tool while you are tired or under the influence of drugs, alcohol or medication.** A moment of inattention while operating power tools may result in serious personal injury.
- **Dress properly. Do not wear loose clothing or jewelry. Contain long hair. Keep your hair, clothing and gloves away from moving parts.** Loose clothes, jewelry or long hair can be caught in moving parts.
- **Do not overreach. Keep proper footing and balance at all times.** Proper footing and balance enables better control of the tool in unexpected situations.
- **Use safety equipment. Always wear eye protection.** Dust mask, non-skid safety shoes, hard hat, or hearing protection must be used for appropriate conditions will reduce personal injuries.

Tool Use and Care

- **Do not force the tool. Use the correct tool for your application.** The correct tool will do the job better and safer at the rate for which it was designed.
- **Do not use the power tool if the switch does not turn**

it **ON** and **OFF**. Any tool that cannot be controlled with the switch is dangerous and must be repaired.

- **Store idle tools out of the reach of children and other untrained persons.** Tools are dangerous in the hands of untrained users.
- **Maintain tools with care. Keep cutting tools sharp and clean.** Properly maintained tools with sharp cutting edges are less likely to bind and are easier to control.
- **Check for misalignment or binding of moving parts, breakage of parts and any other condition that may affect the tool's operation. If damaged, have the tool serviced before using.** Many accidents are caused by poorly maintained tools.
- **Use only accessories that are recommended by the manufacturer for your model.** Accessories that may be suitable for one tool, may become hazardous when used on another tool.

Service

- **Tool service must be performed only by qualified repair personnel.** Service or maintenance performed by unqualified personnel could result in a risk of injury.
- **When servicing a tool, use only identical replacement parts. Follow instructions in the Maintenance section of this manual.** Use of unauthorized parts or failure to follow Maintenance Instructions may create a risk of electrical shock or injury.

Water Jetter Safety Warnings

WARNING

This section contains important safety information that is specific to this tool.

Read these precautions carefully before using this Drain Cleaning Machine to reduce the risk of electrical shock or other serious personal injury.

SAVE ALL WARNINGS AND INSTRUCTIONS FOR FUTURE REFERENCE!

Keep this manual with the machine for use by the operator.

- **Never operate the jetter with the hose end outside of the drain.** Hose can whip, causing striking injuries and spray can penetrate skin and cause serious injury.
- **High pressure water can inject under skin resulting in serious injury including amputation.** Do not direct spray at people or animals.
- **Do not operate jetter above pressure rating or 140°F (inlet water temperature).** This increases the

risk of injury, including burns, and damage to the jetter.

- **One person must control both the jetting process and the foot valve. Always use the foot valve.** If the jetter hose comes out of the drain, the operator must be able to shut the water flow off to reduce the risk of the jetter hose whipping, causing striking and high pressure injection injuries.
- **Always use appropriate personal protective equipment while handling and using drain cleaning equipment.** Drain may contain chemicals, bacteria and other substances that may be toxic, infectious, cause burns or other issues. Appropriate personal protective equipment always includes safety glasses and gloves, and may also include equipment such as latex or rubber gloves, face shields, goggles, protective clothing, respirators, and steel toed footwear.
- **Practice good hygiene. Use hot soapy water to wash hands and other body parts exposed to drain contents after handling or using drain cleaning equipment.** Do not eat or smoke while operating or handling drain cleaning equipment. This will help prevent contamination with toxic or infectious material.
- **Do not spray toxic or flammable liquids.** This will reduce the risk of burns, fire, explosion or other injury.
- **Gasoline and its vapors are highly flammable and explosive.** See engine manual for precautions to reduce the risk of burns, explosions and serious injury while handling and using gasoline.
- **Engines produce carbon monoxide, a colorless, odorless poison gas. Breathing carbon monoxide can cause nausea, fainting or death.** Do not start and run engine in an enclosed area, even if doors and windows are open. Only operate outside.
- **Hot surfaces can cause burns and fire.** Keep body parts and flammable material away from hot surfaces.
- **Read and understand this manual, the engine manual and the warnings and instructions for all equipment being used with this tool before operating.** Failure to follow all warnings and instructions may result in property damage and/or serious injury.

Description, Specifications and Standard Equipment

Description

The RIDGID® Engine Powered Water Jetting Machines are portable high pressure water jetters designed to use a combination of water pressure and flow to clear grease, sludge, sediment and roots out of drains. A highly flexible and lightweight hose is propelled through the drain by the reverse jets on the jetter nozzle, and when retrieved scrubs the line flushing debris away. With the pulse activation engaged, difficult bends and traps are more easily negotiated. All machines are equipped with a gasoline engine to drive the triplex plunger pump.

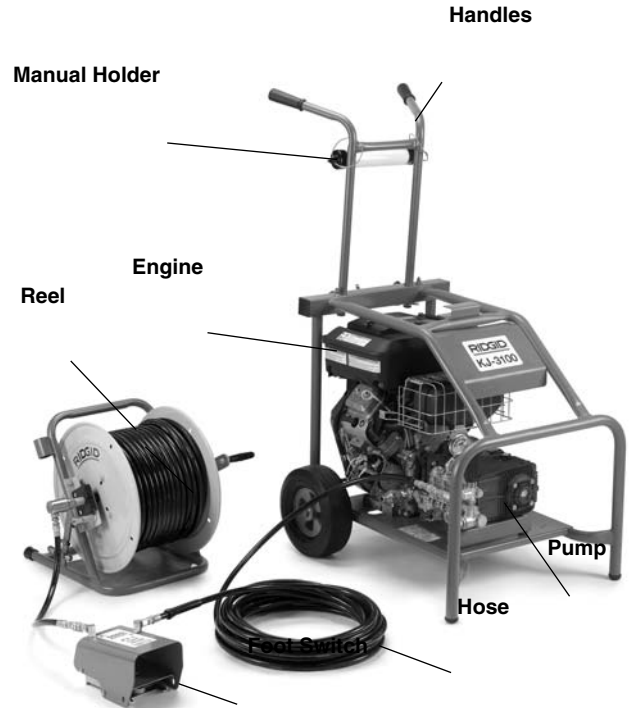
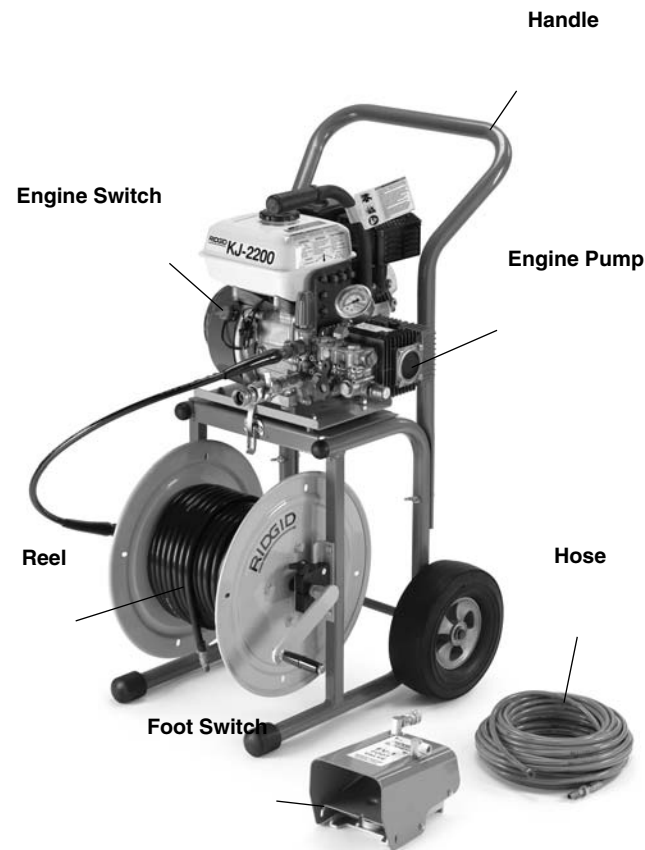

Figure 2 – KJ-3100 Water Jetting Machine



Figure 3 – Machine Serial Number

The machine serial number is located on the frame. The last 4 digits indicate the month and year of the manufacture. (08 = month, 10 = year).

Specifications

Jetter Model	Motor H.P.	Pressure (PSI)	Flow Rate (GPM)	Drain Line Capacity	Weight (lbs) (w/o Hose Reel)
KJ-2200	6.5	2200	2.4	1 1/4" - 6"	65 (30 kg)
KJ-3100	16	3000	5.5	2" - 10"	262 (119 kg)

Icons

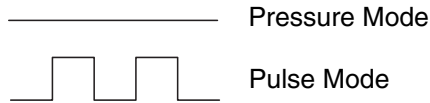

Standard Equipment

All Jetters come with

- Appropriate Jetter Nozzles
- Nozzle Cleaning Tool
- FV-1 Foot Valve
- Engine Operator's Manual

See the RIDGID catalog for specific equipment supplied with each catalog number.

NOTICE This machine is made to clean drains. If properly used it will not damage a drain that is in good condition and properly designed, constructed and maintained. If the drain is in poor condition or not properly designed, constructed or maintained, the drain cleaning process may not be effective or could cause damage to the drain. The best way to determine the condition of a drain before cleaning is through visual inspection with a camera. Improper use of this jetting machine can damage the jetter and the drain. This machine may not clear all blockages.

Machine Assembly

WARNING

To prevent serious injury during use and prevent machine damage, follow these procedures for proper assembly.

Engine Oil

NOTICE Jetter is shipped without oil in the engine. Operating the engine without oil will result in engine failure. Add oil prior to operation. See supplied engine operator's manual for specific information on adding oil and oil selection.

Pump/Gearbox Oil

Pump: Replace the plug in the top of the pump and replace with dipstick/breather cap. Operating the jetter with the plug in place could damage the pump seals. Check oil level per *Maintenance Instruction* section.

Gearbox (KJ-3100 only): Replace the plug in the top of the pump with dipstick/breather cap. Operating the jetter with the plug in place could damage the gearbox seals. Check lubricant level per the *Maintenance Instruction* section.

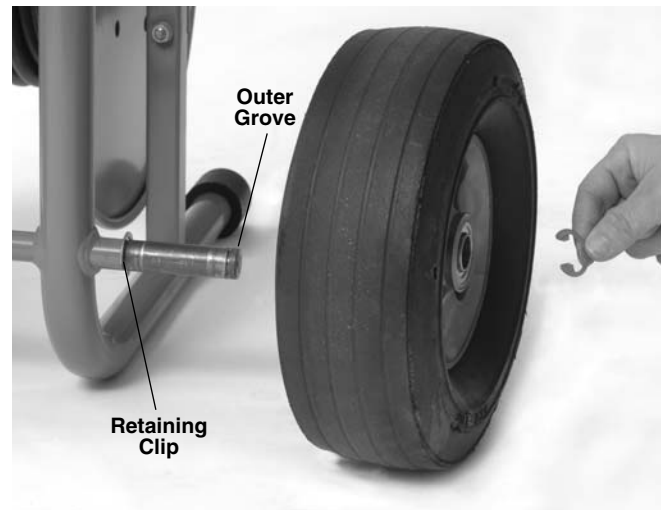

Figure 4 – Assembly of the KJ-2200

KJ-2200 Transport Cart

1. Install retaining clip into inner groove on each end of axle. (See Figure 4.)
2. Slide a wheel over each end of axle.
3. Install retaining clip into outer groove on each end of axle to retain wheel.
4. Use the supplied carriage bolts and wing nuts to attach the handle to the frame.
5. Lift the motor/pump assembly onto the cart, aligning the holes in the base plate with the pins in the top of the cart. Use the latches on the cart to retain the motor/pump. Make sure the assembly is securely attached.

KJ-3100 Handle Assembly

1. Insert handle through the two holes in the rear cross bar of the frame. (See Figure 5.)
2. Insert a hairpin through the holes at the bottom of the handle to prevent the handle from pulling out.
3. Screw the T-knobs into the rear cross bar. Adjust the handles as desired and tighten the knobs to secure the handle.

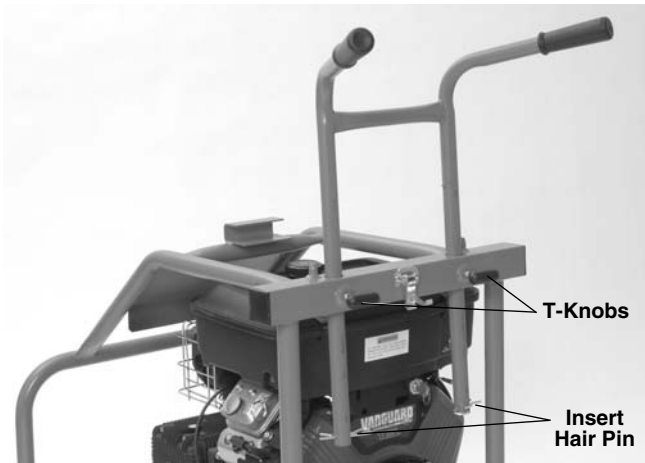

Figure 5 – KJ-3100 Handle Assembly



Figure 6A – KJ-2200 Warning Labels



Figure 6B – KJ-2200 Warning Labels



Figure 6C – KJ-3100 Warning Labels

Pre-Operation Inspection

⚠ WARNING

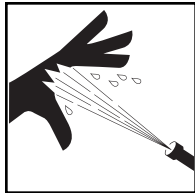

Before each use, inspect your water jetter and correct any problems to reduce the risk of serious injury from high pressure water and other causes and prevent jetter damage.

Always wear safety glasses, gloves and other appropriate protective equipment when inspecting your jetter to protect against chemicals and bacteria on the equipment.

1. Make sure that the engine switch/key is in the OFF position.
2. Clean any oil, grease or dirt from the equipment, including the handles and controls. This aids inspection and helps prevent the machine or control from slipping from your grip.
3. Inspect the water jetter and accessories for the following:
 - Proper assembly and completeness
 - Broken, worn, missing, mis-aligned, binding or loose parts
 - Presence and readability of the warning labels. (See Figure 6)
 - Any other condition which may prevent the safe and normal operation

If any problems are found, do not use the water jetter until the problems are corrected.



Figure 6D – KJ-3100 Warning Labels

- Clean water inlet filter/filter washer. Unscrew cover from bottom of inlet filter for cleaning. Dirt and debris can restrict the water flow to the pump and cause performance issues.

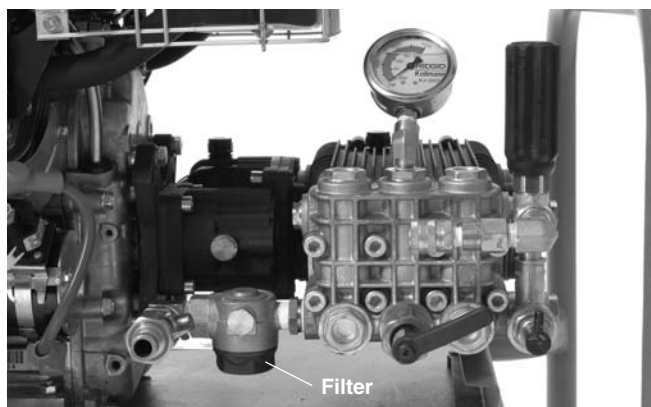

Figure 7 – Inlet Filter/Filter Washer

- Inspect the jetter nozzle orifices for any damage or blockage. Blockages can be cleaned with a nozzle cleaning tool. Use care not to enlarge nozzle orifices while cleaning. Damaged nozzles or nozzles with enlarged orifices can decrease jetter performance and should be replaced.
- Inspect the hoses, connectors and fittings for wear and damage. If there are any kinks, cracks, breaks or wear through the outer jacket of the hose or other damage, do not use the hose. Damaged hoses can burst or leak high pressure water and cause serious injury. Replacement hoses and fitting should be rated at or higher than the jetter pressure.
- Inspect and maintain the engine per the engine operator's manual.
- Check engine fuel level. For the KJ-3100, disconnect the hose reel latch and rotate the hose reel forward until it rests on the frame to provide access to the engine gas cap *Figure 8*. If needed, add unleaded

gasoline. See engine operator's manual for details. Use caution when handling gasoline. Re-fuel in a well ventilated area. Do not overfill tank and do not spill fuel. Make sure tank cap is securely closed.

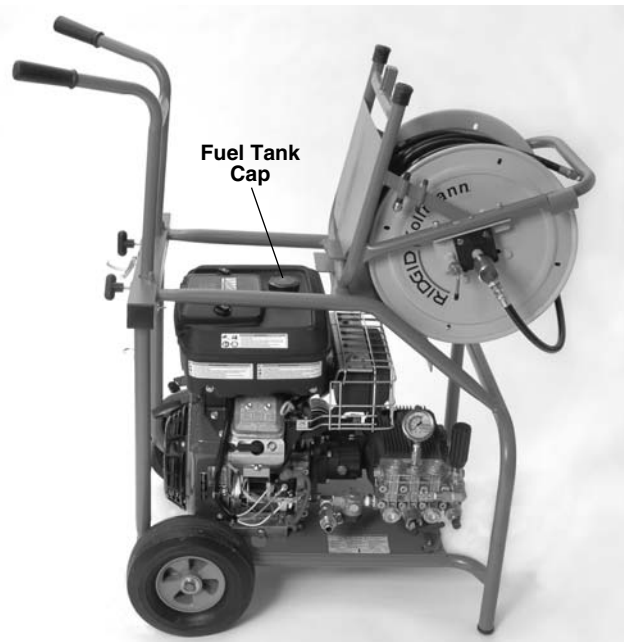

Figure 8 – KJ-3100 Fuel Tank Access

- Check the oil level in the pump and gear box (if equipped) and add oil if needed (*see Maintenance Instructions section*).

Machine and Work Area Set-Up

WARNING



Always wear safety glasses, gloves and other appropriate protective equipment when setting up your jetter to protect against chemicals and bacteria on the equipment. Rubber soled, non-slip shoes can help prevent slipping on wet surfaces.

Engines produce carbon monoxide, a colorless, odorless poison gas. Breathing carbon monoxide can cause nausea, fainting or death. Do not start and run engine in an enclosed area, even if doors and windows are open. Only operate outside.

Set up the jetter and work area according to these procedures to reduce the risk of injury from high pressure water, chemical burns, infections, carbon monoxide and other causes, and prevent jetter damage.

1. Check work area for:
 - Adequate lighting.
 - Flammable liquids, vapors or dust that may ignite. If present, do not work in area until sources have been identified and corrected. The jetter is not explosion proof and can cause sparks.
 - Clear, level, stable dry place for machine and operator. If needed, remove the water from the work area. Wood or other coverings may need to be put down.
 - Jetter location that is in a well ventilated outdoor area. Do not place the jetter indoors, even with doors and windows open. Jetter can be located remotely from the point of use.
 - Suitable water supply.
 - Clear path to transport the jetter to the set up location.
2. Inspect the drain to be cleaned. If possible, determine the access point(s) to the drain, the size(s) and length(s) of the drain, distance to tanks or mainlines, the nature of the blockage, presence of drain cleaning chemicals or other chemicals, etc. If chemicals are present in the drain, it is important to understand the specific safety measures required to work around those chemicals. Contact the chemical manufacturer for required information.

If needed, remove fixture (water closet, etc.) to allow access to the drain. Do not feed the hose through a fixture. This could damage the hose and the fixture.
3. Determine the correct equipment for the application. See the *Specifications* section for information on these jetters. Drain cleaners and jetters for other applications can be found by consulting the RIDGID Catalog
4. Make sure all equipment has been properly inspected.
5. Evaluate the work area and determine if any barriers are needed to keep bystanders away. Bystanders can distract the operator. If working near traffic, erect cones or other barriers to alert drivers.
6. If needed, place protective covers in the work area. The drain cleaning process can be messy.
7. Take the jetter to the well-ventilated outdoor work area along the clear path. If the machine needs to be lifted, use proper lifting techniques. Use care moving equipment up and down stairs, and be aware of possible slip hazards. Wear appropriate footwear to help prevent slips.

Water Supply

Confirm that there is sufficient water flow for jetter. Run a

hose from the water source to the jetter. Use the largest diameter, shortest length hose possible. A 3/4" I.D. hose is the minimum recommended size. An appropriate backflow prevention device should be used to comply with all local codes and ordinances. Turn the water on at the source and measure the time it takes to fill a clean five gallon bucket. *See the following table for maximum bucket fill times for each jetter.*

Jetter	GPM Rating	Maximum 5 Gallon Bucket Fill Time
KJ-2200	2.4	125 seconds
KJ-3100	5.5	55 seconds

Insufficient water flow will prevent the jetter from reaching the pressure rating and could damage the pump. Inspect the water in the bucket for dirt and debris. Dirt and debris in the water supply can cause excess pump wear, clog the jetter filters nozzles and reduce performance. Do not use water from ponds, lakes or other sources that may be contaminated.

In cases of insufficient water flow, possible solutions include using fittings to allow multiple supply hoses to be connected to the jetter or the use of a tank.

If a tank is used, plumb a tee with full port valves to the jetter water inlet as shown in *Figure 9*. Connect a 3/4" (19 mm) hose no longer than 6 feet (1.8 m) to the valve on the outlet of the tee, and connect the water supply to the run of the tee. Either place the hose end in the tank or connect to the tank outlet. The entire length of the tank hose should be no more than 5" (12.7 cm) above the jetter water inlet, or the jetter will not draw water from the tank.

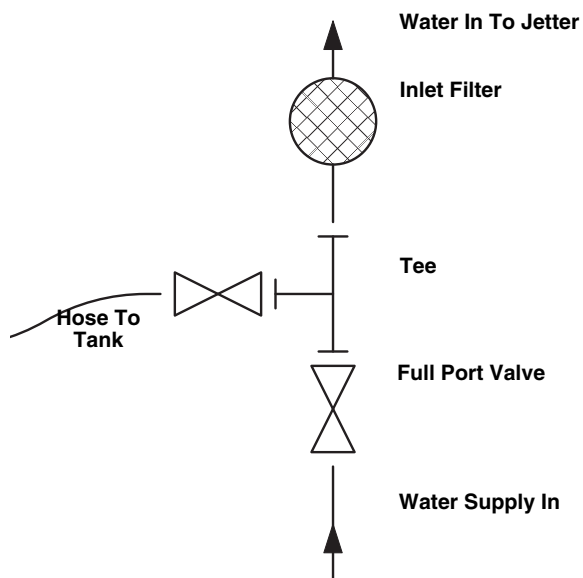

Fill the tank prior to starting the jetter. When starting jetter, turn the tank valve OFF. As soon as the jetter is started, open the tank valve. Monitor the tank water level, and if needed, stop jetting to allow the tank to refill. Do not allow the water level to fall below the hose end.

Hot water can be used for improved cleaning. Do not use water hotter than 140°F. – this can cause the pump thermal overload to open. When using hot water, use appropriate personal protective equipment to reduce the risk of burns.

When using in cold weather, use precautions to prevent water from freezing in the pump. This can damage the pump.

Make sure that the inlet supply valve on the jetter is closed and attach the supply hose to the jetter.

Drain Preparation

If working through a manhole, storm grate or other large access, use pipe and fittings to create a guide for the jetter hose from the drain opening to operation point. This will prevent the jetter hose from whipping around in the access and protect the hose from damage.



Figure 10 – Extending the Drain Opening to the Operation Point

Hose Set-Up

Use care when routing jetter hoses. Routing hoses over rough surfaces, sharp edges, crossing hoses, etc. can damage the hose jacket, especially when the jetter is used in the pulse mode. Keeping the jetter hose on the reel will help to minimize hose damage.

1. Select a jetter hose size appropriate for the drain being cleaned. It is not generally recommended to connect two jetter hoses together for cleaning drains. The connection between the two hoses is less flexible and can prevent passage through fittings. See *Jetter Hose Selection Chart*.
2. As needed, separate the hose reel from the motor/pump assembly. Locate the hose reel within 3 feet of the drain opening. Do not allow excessive amounts of hose outside of the drain to prevent hose damage. If the hose reel cannot be placed within 3 feet of the drain opening, extend the drain opening back to the hose reel with similar sized pipe and fittings.
3. Route a hose from the jetter to the IN fitting on the foot valve. Use PTFE tape to seal the connection. Position the foot valve for accessibility. You must be able to control the jetter hose and the foot valve.
4. Connect the hose from the reel to the OUT fitting on the foot valve.

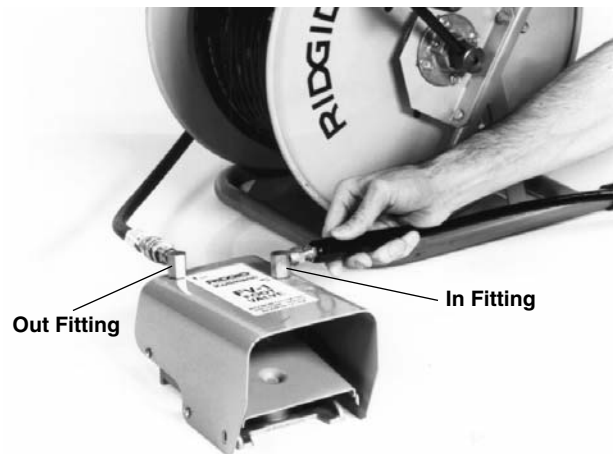

Figure 11 – Foot Valve Connection

5. Mark the jetter hose near the end to indicate when the nozzle is getting close to the drain opening when withdrawn. This will help prevent the nozzle from coming out of the drain and whipping around. The distance depends on the configuration of the drain, but should be at least 4'/1.2 m.
6. Remove the nozzle from the end of the jetter hose and place the end of the jetter hose in the drain. Open the inlet supply valve to purge the air and any debris from the jetter and hoses. Allow water to flow for at least 2 minutes.
7. Close the inlet supply valve.
8. Select a nozzle. Use nozzles specifically sized for the jetter being used. Using incorrect nozzles can cause poor performance (low operating pressure or low flow) or may damage the jetter with excessively high

pressures. Make sure the nozzle orifices are clear and open. See *Jetter Nozzle Selection Chart*.

If using the RR3000 nozzle for drains larger than 6" and up to 9"/ 229 mm, the extension must be used. For drains 6"/ 152 mm and smaller, no extension is needed. If needed, firmly hand tighten the extension to the RR3000 – do not over tighten. Using the RR3000 nozzle in a line larger than 6" and up to 9" without an extension, or in lines larger than 9" may allow the nozzle to change direction in the drain, exit at the user and cause serious injury (*Figure 12*).

9. Firmly hand tighten the nozzle to the end of the hose – do not over tighten. Over tightening the nozzle can damage the nozzle and cause poor performance.
10. Insert the hose with nozzle attached into the drain and

open the inlet supply valve. Confirm that water flows freely through the nozzle and close the inlet supply valve.



Figure 12 – RR3000 Nozzle with Extension

JETTER HOSE SELECTION CHART

Applications		Pipe Size	Nozzle Size	Hose Size (ID)	Hose Size (OD)
KJ-2200	Bathroom sinks, urinals, and small lines.	1 1/4" – 2"	1/8" NPT	1/8"	3/16"
	Kitchen sinks, laundry tubs and stacks, clean-outs, and vents.	2" – 3"	1/8" NPT	3/16"	1/4"
	Shower and floor drains, lateral lines, and grease traps.	3" – 4"	1/4" NPT	1/4"	1/2"
	Lateral and main lines.	4" – 6"	1/4" NPT	1/4"	1/2"
KJ-3100	Stacks, clean-outs and vents.	2" – 3"	1/8" NPT	3/16"	1/4"
	Floor drains, lateral lines, and grease traps.	3" – 4"	1/4" NPT	3/8"	5/8"
	Lateral and main lines.	4" – 10"	1/4" NPT	3/8"	5/8"

JETTER NOZZLE SELECTION CHART

KJ-2200	Thread Size	1/8" NPT	1/4" NPT
	Hose Size (Inside Diameter)	1/8" & 3/16"	1/4"
	Hose Size (Outside Diameter)	3/16" & 1/4"	1/2"
	Features three reverse jet thrusts for maximum propulsion to jet long distances. Use this nozzle for most applications.	H-61	H-71
	Uses three jet thrusters in reverse plus one jet pointed forward to penetrate solid grease or sludge blockages. The forward jet blasts a small hole in the blockage for the nozzle to follow. It is also very effective when jetting ice blockages.	H-62	H-72
	Use the drop head to help negotiate difficult bends. This nozzle has three reverse jet thrusts.	H-64	
	Use the spinning nozzle to clean grease and similar blockage from drain.	H-65	H-75
KJ-3100	Thread Size	1/8" NPT	1/4" NPT
	Hose Size (Inside Diameter)	3/16"	3/8"
	Hose Size (Outside Diameter)	1/4"	5/8"
	Features four (4) reverse jet thrusts for maximum propulsion to jet long distances. Use this nozzle for most applications.	H-101	H-111
	Uses three jet thrusters in reverse plus one jet pointed forward to penetrate solid grease or sludge blockages. The forward jet blasts a small hole in the blockage for the nozzle to follow. It is also very effective when jetting ice blockages.	H-102	H-112
	Use the drop head to help negotiate difficult bends. This nozzle has four (4) reverse jet thrusts.	H-104	
	Use the spinning nozzle to help clean grease and similar blockage from drain.	H-105	H-115
Use to clear roots and other type of blockages. NOTE! Use extension to stabilize the RR3000 when cleaning 8" diameter drains.		RR3000	

Operating Instructions

WARNING

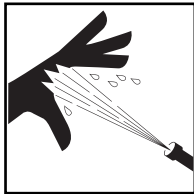

Always wear eye protection to protect your eyes against dirt and other foreign objects. Always wear appropriate personal protective equipment for the work environment.

Never operate the jetter with the hose end outside of the drain. Hose can whip, causing striking injuries and spray can penetrate skin and cause serious injury.

High pressure fluid can inject under skin resulting in serious injury, including amputation. Do not direct spray at people or animals.

Do not operate jetter above pressure rating or 140°F (inlet water temperature). This increases the risk of injury, including burns, and damage to the jetter.

One person must control both the jetting process and the foot valve. Always use the foot valve. If the jetter hose comes out of the drain, the operator must be able to shut the water flow off to reduce the risk of the jetter hose whipping, causing striking and high pressure injection injuries.

Always use appropriate personal protective equipment while handling and using drain cleaning equipment. Drain may contain chemicals, bacteria and other substances that may be toxic, infectious, cause burns or other issues. Appropriate personal protective equipment always includes safety glasses and gloves, and may also include equipment such as latex or rubber gloves, face shields, goggles, protective clothing, respirators, and steel toed footwear.

Follow operating instructions to reduce the risk of injury from whipping hoses, high pressure liquid injection, carbon monoxide and other causes.

1. Make sure that machine and work area is properly set up and that the work area is free of bystanders and other distractions. If the jetter is located remotely from the point of use, another person should be located at the jetter.
2. Insert the hose with nozzle attached into the drain at least three feet so that the end of the hose will not come out of the drain and whip around when the machine is started.
3. Confirm that the pulse actuator lever is rotated counter-clockwise in the "Pressure" position (*Figure 16*).

4. Open the inlet supply valve. Never start the engine without the water supply turned ON. This can damage the pump.
5. Press the foot valve to reduce pressure and allow the engine to start. Confirm that water flows freely through the nozzle. Following the starting instructions supplied in the engine manual, start the engine. Allow the engine to warm up.

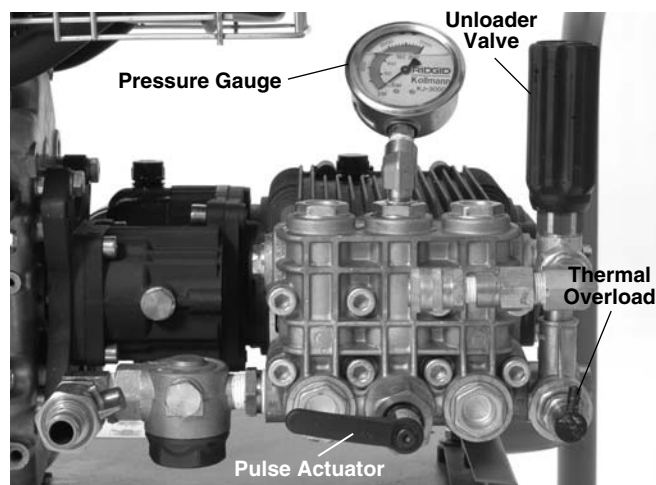

Figure 13 – Controls

6. Turn the unloader valve while monitoring the pressure gauge to adjust the pressure as desired (clockwise to increase pressure, counter-clockwise to decrease pressure). Do not exceed the machine pressure rating being used. Do not force the unloader valve or use wrenches or tools to turn. This will damage the unloader valve.

Jetter	Pressure Rating
KJ-2200	2200 psi
KJ-3100	3000 psi

If the jetter will not generate the rated pressure or is erratic

- Make sure the engine throttle is properly adjusted.
- Make sure that the inlet supply valve is fully open and other valves in the supply system are fully open.
- Turn unloader valve clockwise to increase pressure. Do not force.
- Make sure the pulse actuator is on the "Pressure" setting.
- Cycle the pulse actuator between the "Pressure" and "Pulse" position several times while the unit is running to clear any trapped air from the system.

- Inspect system for leaks. Use caution during inspection to prevent injury. If leaks are found, shut jetter OFF before fixing.
- Turn the jetter OFF. Check the inlet filter/filter washer and make sure that they clear of debris.
- Make sure there is adequate water flow to the jetter.
- Turn the jetter and inlet supply valve OFF. Remove the nozzle and clean the orifices with the nozzle cleaning tool.
- Run the jetter without a nozzle on the hose to remove air or debris from the system. Turn the jetter OFF before removing or attaching the nozzle.

7. Assume a proper operating position.

- Be sure you can control the ON/OFF action of the foot valve. Do not press the foot valve yet.
- Be sure that you have good balance and do not have to overreach.
- You must be able to place one hand on the jetter hose at all times to control and support the hose.
- You must be able to reach the reel for coiling the hose.

This operating position will help to maintain control of the jetter hose.



Figure 14 – Proper Operating Position

Jetting the Drain

When jetting a drain, typically the hose is fed into the drain the full distance to be cleaned and slowly pulled back. This allows the high pressure water directed at the drain walls to remove build-up.

Release the locking pin on the hose reel. With at least three feet of hose in the drain and one hand on the hose to control its movement, depress the foot valve. The reverse jet thrusters on the nozzle will help pull the hose into the drain. Feed the hose in the as far as needs to be cleaned. If the hose stops, it has encountered some type of obstruction.

If the nozzle cannot pass through an obstruction, such as a change in direction (trap, turn, etc.) or a blockage.

- Use sharp thrusts of the hose
- Rotate the hose a quarter to half turn to orient the set of the hose to the direction change (If the hose is rotated, once through the obstruction, turn the hose back to help prevent kinks) See Figure 15.
- Use the pulse mode.  (see next section)
- Use a trap hose or smaller diameter hose.



Figure 15 – Rotating the Hose.

Once past a blockage, take the time to clean that section of drain prior to moving forward. Move several feet past the area of the obstruction and slowly pull the nozzle back through the area of the obstruction. Do this several times and then move further into the drain.

Watch the drain water level. If the water level gets too high, you may need to turn the jetter OFF and allow the water to drain prior to continuing. Jetting when the line is full of water is less effective than when the line is empty. Do not allow the jetter to run for extended period of time with the foot valve OFF. When the foot valve is OFF, water recirculates in the pump and cause the water to heat up. This can cause the pump thermal overload to open.

Once the nozzle is the desired distance into the drain, slowly (1 ft /minute for heavy drain accumulations) pull the nozzle back through the drain. Use one hand to control the hose and the other to wind the hose onto the reel. Watch as the nozzle gets closer to the drain opening that the nozzle does not come out of the drain while water is flowing. This could allow the hose to whip around and cause striking and high pressure fluid injuries. Always control the hose. Look for the mark on the hose near the nozzle. Release the foot valve to shut off the water flow.

Turn OFF the engine as directed in the engine manual, and depress the foot valve to release the system pressure. Never leave the system pressurized. If needed, change the nozzle and continue cleaning following the above process. Several passes through a line are recommended for complete cleaning.

When finished, with the jetter shut off, remove the nozzle and open inlet supply valve to flush out the pump and hose. If using the jetter in cold weather conditions, immediately drain the water from the system to help prevent damage from freezing. See *Machine Storage* for information on freeze protecting.

Using the Pulse Mode

When manipulating the hose is not enough to pass through a direction change or obstruction, the pulse mode should be used. The pulse mode induces large variation in water pressure that causes the hose to vibrate, easing hose advancement.

1. Turn the pulse actuator lever clockwise to the “Pulse” position. In pulse mode, the pressure gauge will read less than full pressure. This is normal.

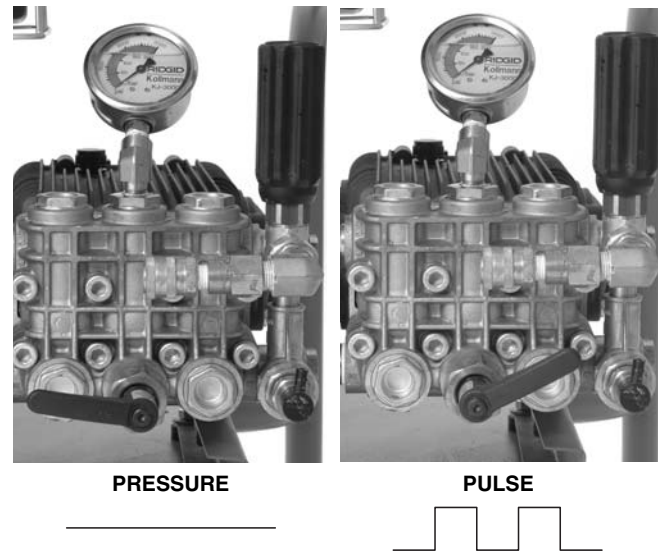

Figure 16 – Pulse Actuator Lever Position

2. If needed, use sharp thrusts of the hose and hose rotation to help the nozzle through the obstruction.
3. Once through the obstruction, turn the pulse actuator lever counter-clockwise to the “Pressure” position. Do not leave the jetter in pulse mode any longer than needed to pass through an obstruction. Excessive use of the pulse feature can cause premature wear on hoses and system.

Using Water Jetter Machine as a Pressure Washer

The RIDGID water jetting machines can also be used as pressure washers with the addition of the pressure wash package. Use as a pressure washer is similar to use as a jetter, and those instructions should be used in conjunction with the following.

1. Locate an appropriate work area.
2. Make sure all equipment has been properly inspected.
3. Attach the wash wand to the wash wand hose. Always use hose with a pressure rating at least as high as the jetter pressure rating. Use a thread sealant to prevent leaks.
4. Attach hose to the jetter outlet. Make sure the ends of the hose are securely connected to prevent them from coming off under pressure.
5. Connect an appropriate water supply, as discussed earlier, to the jetter.
6. Open the inlet supply valve and squeeze the wash wand trigger to allow water to flow and purge any air from the system. Never start the engine without the water supply turned ON. This can damage the pump.

7. Make sure that pulse actuator lever is rotated counter-clockwise in the "Pressure" position.
8. Wash Wand Nozzle Adjustments – By rotating the nozzle, the wash pattern can be adjusted from a fine stream to a wide fan type spray. By pulling the nozzle forward (low pressure) and backward (high pressure), the pressure can be adjusted. Make sure that the nozzle is pulled back to the high pressure position to start operation.

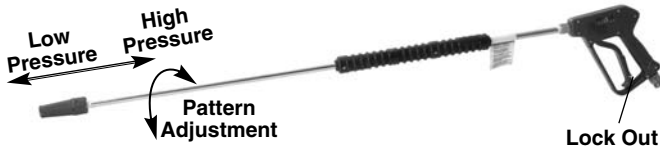

Figure 17 – Wash Wand Nozzle Adjustments

9. Wash Wand Lock Out – the wash wand includes a lock out on the back of the trigger. Flip the lock out down to prevent the operation of the trigger when the wash wand is not in use.
10. With the wand pointed in a safe direction, squeeze the wash wand trigger to reduce pressure and allow the engine to be started. Following the starting instructions supplied in the engine manual, start the engine. Allow the engine to warm up. Release the trigger as soon as the engine starts.
11. With the wand pointed in a safe direction, squeeze the wash wand trigger. Turn the unloader valve while monitoring the pressure gauge to adjust the pressure as desired. Do not exceed the machine pressure rating. Release the wash wand trigger.

Pressure Washer Operation

1. When using as a pressure washer use both hands to grip and direct the wash wand for greater control. Never direct the wash wand at people. High pressure fluid can inject under skin resulting in serious injury. Never direct wash wand at electrical equipment or wiring to reduce the risk of electrical shock.
2. Control the flow of water with the trigger. Use care when using the pressure washer. Holding the nozzle too close to a surface can damage it. Test a small, inconspicuous area to confirm the settings work as desired.
3. Do not allow the jetter to run for extended period of time with the trigger OFF. When the trigger is OFF, water recirculates in the pump and it causes the water to heat up. This can cause the pump thermal overload to open.

4. Once pressure washing is complete, release the trigger and turn OFF the engine as directed in the engine manual. Squeeze the trigger to release system pressure. Never leave the system pressurized.

Detergent Injector

1. If needed, attach the detergent injector to the outlet port. Remove the output hose and attach the detergent injector with arrow on the unit pointing the same direction as the water flow. Use thread sealant to prevent leaks. Reattach the output hose.
2. Attach the siphon hose to the detergent injector. Place the strainer end of hose into the detergent container. Only use detergents designed for use with pressure washers. Follow all detergent instructions. Do not spray flammable liquids or toxic chemicals. Other detergents, solvents, cleaners, etc. can damage the jetter, or cause serious injury.
3. When pressure washing, detergents are only dispensed when wash wand nozzle is in the low pressure position. Pull the nozzle forward to the low pressure position to dispense detergent.
4. During operation, the detergent application rate can be adjusted by turning the sleeve on the detergent injector. Counter-clockwise increases the amount of detergent, clockwise decreases.
5. When detergent application is complete, remove the strainer from the detergent, place into a bucket of clean water and flush the system of any detergent.

Maintenance Instructions

⚠ WARNING

Before performing any maintenance, engine switch should be in OFF position and spark plug wires should be disconnected to prevent inadvertent operation. Press foot valve or wand trigger to release any fluid pressure in system.

Always wear safety glasses and gloves when performing any maintenance to help protect against drain chemicals and bacteria.

Cleaning

The hose should be cleaned as needed with hot, soapy water and/or disinfectants. Do not allow water to enter the engine or electrical system. Do not clean with pressure washer. Wipe the unit down with a damp cloth.

Engine

Maintain the engine as directed in the engine operator's manual supplied with the unit.

Pump Lubrication

Check the pump oil level prior to use. Place the jetter on a level surface. Wipe any dirt and debris from the area of the dipstick and remove the dipstick – check the oil level. If needed, add SAE 30W non-detergent oil. Do not overfill. Reinstall dipstick.

Change oil in pump after first 50 hours of operation and every 500 hours of operation after that. With the pump warm from operation, remove plug on bottom of pump and drain oil into suitable container. Replace plug. Fill with approximately 32 oz of SAE 30W non-detergent oil using the checking procedure.

Gearbox Lubrication

Check the gearbox oil level prior to use. Place the jetter on a level surface. Wipe any dirt and debris from the area of the dipstick and remove the dipstick – check the oil level. If needed, add SAE 90W gear lubricant. Do not overfill. Reinstall dipstick.

Change oil in gearbox every 500 hours of operation. With the gearbox warm from operation, remove plug on bottom of gearbox and drain oil into suitable container. Replace plug. Fill with approximately 8 oz of SAE 90W gear lubricant oil using the checking procedure.

Preparing Pump for Cold Weather Storage

NOTICE If the jetter will be stored under conditions where the temperature is near or below 32°F (0°C), the jetter must be properly prepared. If water freezes in the pump, it can damage it.

There are two methods for preparing the jetter for cold weather storage. The first is to open all valves in the system and use compressed air to force any water out of the system. This can also be used to remove water from the hoses.

The second method uses RV antifreeze (non-ethylene glycol antifreeze). Do not use ethylene glycol antifreeze in the jetter pump. Ethylene glycol cannot be used in drainage systems.

1. Attach a 3 foot section of hose to the inlet supply valve and open valve.
2. Place the end of the hose into the container of RV antifreeze.
3. Remove the nozzle from the end of the hose.

4. Start the jetter and run until antifreeze comes out of the end of the hose.

Accessories

⚠ WARNING

To reduce the risk of serious injury, only use accessories specifically designed and recommended for use with the RIDGID Water Jetter Machines, such as those listed below. Other accessories suitable for use with other tools may be hazardous when used with RIDGID Water Jetter Machines.

KJ-2200 Jetter Nozzles and Hoses

Catalog No.	Model No.	Description	Hose I.D.	Hose O.D.
64772	H-61	Propulsion Nozzle	1/8" NPT	
64777	H-62	Penetrating Nozzle	Fits 1/4" Hose	
64782	H-64	Drop Head Nozzle		
82842	H-65	Spin Nozzle 2200		
64787	H-71	Propulsion Nozzle	1/4" NPT	
64792	H-72	Penetrating Nozzle	Fits 1/2" Hose	
82852	H-75	Spin Nozzle 2200		
47592	H-1425	1/4" x 25'	3/16"	1/4"
47597	H-1435	1/4" x 35'	3/16"	1/4"
47602	H-1450	1/4" x 50'	3/16"	1/4"
49272	H-1475	1/4" x 75'	3/16"	1/4"
49277	H-1400	1/4" x 100'	3/16"	1/4"
64732	H-1415	1/4" x 150'	3/16"	1/4"
50002	HL-1	Flexible Leader, 1/4"	1/8"	3/16"
50007	HL-2	Flexible Leader, 1/2"	1/8"	3/16"
47607	H-1250	1/2" x 50'	1/4"	1/2"
47612	H-1275	1/2" x 75'	1/4"	1/2"
47617	H-1200	1/2" x 100'	1/4"	1/2"
51587	H-1211	1/2" x 110'	1/4"	1/2"
49487	H-1215	1/2" x 150'	1/4"	1/2"
51597	H-1220	1/2" x 200'	1/4"	1/2"

KJ-2200 Jetter Accessories

Catalog No.	Model No.	Description
62882	H-5	Mini Hose Reel (No Hose included)
64737	H-30	H-30 Cart with Hose Reel
62877	H-30 WH	H-30 Cart with Hose Reel and 110' x 1/2" Jet Hose
64077	HP-22	Pressure Wash Package, KJ-2200
64767	HW-22	Wash Wand, KJ-2200
51572	H-1235	Wash Wand Hose 1/2" x 35'
48157	FV-1	Foot Valve
66732	HF-4	Quick Connect Hose
48367	H-25	Winterizing Kit
47542	H-21	Nozzle Cleaning Tool
67187	H-32	Jet Vac

KJ-3100 Jetter Nozzles and Hoses

Catalog No.	Model No.	Description	Hose I.D.	Hose O.D.
38698 38713 38703 38723	H-101 H-102 H-104 H-105	Propulsion Nozzle Penetrating Nozzle Drop Head Nozzle $\frac{1}{8}$ " NPT Spin Nozzle	$\frac{1}{8}$ " NPT Fits $\frac{1}{4}$ " Hose	
38693 38708 38718 16713	H-111 H-112 H-115S RR3000	Propulsion Nozzle Penetrating Nozzle $\frac{1}{4}$ " NPT Spin Nozzle Root Ranger Nozzle	$\frac{1}{4}$ " NPT Fits $\frac{3}{8}$ " Hose	
47592 47597 47602 49272 49277 64732	H-1425 H-1435 H-1450 H-1475 H-1400 H-1415	$\frac{1}{4}$ " x 25' Trap Hose $\frac{1}{4}$ " x 35' Trap Hose $\frac{1}{4}$ " x 50' Trap Hose $\frac{1}{4}$ " x 75' Trap Hose $\frac{1}{4}$ " x 100' Trap Hose $\frac{1}{4}$ " x 150' Trap Hose	$\frac{1}{4}$ " Trap Hose Orange	$\frac{3}{16}$ " $\frac{3}{16}$ " $\frac{3}{16}$ " $\frac{3}{16}$ " $\frac{3}{16}$ " $\frac{3}{16}$ "
64827 64832 64837 64842 64847 64852 64857	H-3835 H-3850 H-3810 H-3815 H-3820 H-3825 H-3830	$\frac{3}{8}$ " ID x 35' Wash Hose $\frac{3}{8}$ " ID x 50' Jet/Wash Hose $\frac{3}{8}$ " ID x 100' Jet Hose $\frac{3}{8}$ " ID x 150' Jet Hose $\frac{3}{8}$ " ID x 200' Jet Hose $\frac{3}{8}$ " ID x 250' Jet Hose $\frac{3}{8}$ " ID x 300' Jet Hose	$\frac{3}{8}$ " Jet Hose Black	$\frac{5}{8}$ " $\frac{5}{8}$ " $\frac{5}{8}$ " $\frac{5}{8}$ " $\frac{5}{8}$ " $\frac{5}{8}$ " $\frac{5}{8}$ "

KJ-3100 Jetter Accessories

Catalog No.	Model No.	Description
62882	H-5	Mini Hose Reel
64862	H-38	Hose Reel (Fits KJ-3100)
64902	H-38 WH	Hose Reel with 200' x $\frac{3}{8}$ " ID Hose (Fits KJ-3100)
64797	HW-30	Wash Wand, KJ-3100
48367	H-25	Winterizing Kit
48157	FV-1	Foot Valve
66732	HF-4	Quick Connect Hose (Reel to Foot Valve)
47542	H-21	Nozzle Cleaning Tool
67187	H-32	Jet Vac

Machine Storage

⚠ Store the jetter in a well ventilated area protected from rain and snow. Keep the machine in a locked area that is out of reach of children and people unfamiliar with jettors. This machine can cause serious injury in the hands of untrained users. *See Maintenance section* for information on cold weather storage. See engine operator's manual for specific information on engine storage.

Service And Repair
⚠ WARNING

Improper service or repair can make machine unsafe to operate.

The "Maintenance Instructions" will take care of most of the service needs of this machine. Any problems not addressed by this section should only be handled by an authorized RIDGID service technician.

Tool should be taken to a RIDGID Independent Authorized Service Center or returned to the factory.

For information on your nearest RIDGID Independent Service Center or any service or repair questions:

- Contact your local RIDGID distributor.

Disposal

Parts of the water jetter contain valuable materials and can be recycled. There are companies that specialize in recycling that may be found locally. Dispose of the components in compliance with all applicable regulations. Contact your local waste management authority for more information.

For EC Countries: Do not dispose of electrical equipment with household waste!

According to the European Guideline 2002/96/EC for Waste Electrical and Electronic Equipment and its implementation into national legislation, electrical equipment that is sable must be collected separately and dis-an environmentally correct manner.



Troubleshooting

PROBLEM	CAUSE	CORRECTION
<p>Jetter runs but produces little or no pressure.</p>	<p>Inadequate water supply.</p>	<p>Make certain water supply faucet is ON.</p> <p>Make certain jetter's water supply inlet valve is ON.</p> <p>Make certain water supply hose is clear and not kinked or collapsed.</p>
<p>Jetter will not adjust to full operating pressure at start-up.</p>	<p>Air is trapped in system.</p> <p>Jetter nozzle thrusters are blocked.</p>	<p>Remove nozzle from jet hose and run jetter to flush air/debris from system.</p> <p>Remove nozzle and clean thruster orifices with nozzle cleaning tool.</p>
<p>Jetter pressure gage oscillates from 500 to full operating pressure.</p>	<p>Jetter nozzle thrusters are blocked.</p> <p>Debris or air trapped in system.</p>	<p>Remove nozzle. Use nozzle cleaning tool to clear nozzle orifices: select proper wire size and push completely through each thruster orifice to remove debris.</p> <p>Remove nozzle and insert jet hose in drain line. Run jetter to flush trapped air or debris.</p>