



Hi-Flow™ Control Valves

Globe Valves, Ideal for Steam and Water Flow Control, 1/2" to 2-1/2" Sizes, 2-Way or 3-Way



2-way with positioner



2-way with air-to-close actuator



2-way with air-to-open actuator

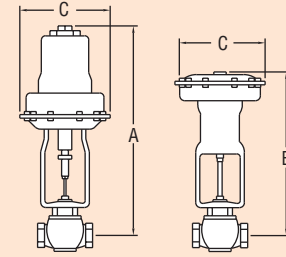

Caution: Use of an actuator supply gas other than air can create a hazardous environment because a small amount of gas continuously vents to atmosphere.

Hi-Flow™ control valves are single seated, top or cage guided globe valves - probably the simplest, from a construction standpoint, yet most versatile control valve in use. The Hi-Flow™ valve can fit applications with a smaller size valve since the valve has a greater flow capacity than most conventional valves of the same size.

Coupled with the high flow capacity, the Hi-Flow™ valve maintains a wide rangeability of 50:1 to insure precise control. Heavy duty Hi-Flow™ valves are ruggedly constructed of the highest quality materials, precision machined, and performance tested to assure years of trouble free service. Standard packing consists of PTFE V-rings and wiper to minimize friction without leakage at high operating pressures. Available in brass, iron, or 316 SS body, trim is 316 SS with all welded plug construction to provide superior durability and corrosion resistance.

FEATURES

- Wide rangeability of 50:1
- Exceptional shut-off and leak rate that meets ANSI/FCI 70-2 Class IV (0.01% of Cv in the closed position)
- Selectable fail safe condition with Air-to-Raise or Air-to-Lower actuators and Push-to-Open or Push-to-Close valve bodies
- Linear or equal percentage flow characteristics
- Low flow options of restricted trim or needle plug
- Removable and replaceable seat ring

APPLICATIONS

- Flow control, mixing, or diverting service
- Perfect for steam, water or compatible glycol solutions

SPECIFICATIONS

VALVE BODY

Service: Compatible liquids, gases, and steam.

Line Size: 1/2" to 2-1/2".

Body Style: 2-way or 3-way globe.

End Connections: 1/2" to 2" female NPT, 2-1/2" flanged.

Pressure Limit: Iron and bronze body: 250 psi (17.2 bar); 316 SS body: 300 psi (20.7 bar).

Wetted Materials:

Body material: Iron, bronze, or 316 SS;

Trim: 316 SS.

Packing: PTFE.

Temperature Limits: 20 to 400°F (-7 to 204.4°C).

ACTUATOR

Type: Pneumatic spring/diaphragm.

Control Signal: 3 to 15 psi (0.21 to 1.0 bar) standard. Custom ranges available.

Maximum Supply Pressure: 220, 222, and 230: 100 psi (6.89 bar). 221, 223, 231, and 233: 50 psi (3.45 bar).

Air Connection: 1/4" female NPT.

Temperature Limit: 150°F (66°C).

Positioners and current-to-pressure transducers available factory mounted. ① ②

How to Order:

Select model number from model chart or standard product chart and supply maximum upstream pressure, USP.

① Positioners: See page 522 (Series 165)

② Transducers: See page 520 (Series 2800)

See page 521 (Series 2900)



Hi-Flow™ Control Valves

2-Way Simplified Selection Guide with Standard Products

Use the chart below to aid in the selection of Hi-Flow™ Control Valve. As long as the maximum upstream pressure (USP) is less than, or equal to, the value listed, the model shown can be manufactured and calibrated to your specific requirements. Specify maximum upstream pressure, USP, when ordering.

Pipe Size	Cv 100%	Body Material	Model (Air-To-Open)	Max USP psi (bar) 3-15 (.21-1.0)	A in (mm)	C in (mm)	Model (Air-To-Close)	Max. USP psi (bar) 3-15 (.21-1.0)	B in (mm)	C in (mm)
1/2"	6.45	Bronze	2000VA32-230	250 (17.2)	19-3/4 (501.7)	7-3/4 (196.9)	2000VA32-220	250 (17.2)	18-7/16 (468.3)	7-3/4 (196.9)
		316SS	2000VA42-230	300 (20.7)	19-3/4 (501.7)	7-3/4 (196.9)	2000VA42-220	300 (20.7)	18-7/16 (468.3)	7-3/4 (196.9)
3/4"	10.75	Bronze	2001VA32-230	250 (17.2)	19-3/4 (501.7)	7-3/4 (196.9)	2001VA32-220	250 (17.2)	18-7/16 (468.3)	7-3/4 (196.9)
			2001VA32-231	250 (17.2)	20-3/8 (517.5)	10-5/8 (269.9)	2001VA32-221	250 (17.2)	19-1/8 (485.8)	10-5/8 (269.9)
		316SS	2001VA42-230	285 (19.7)	19-3/4 (501.7)	7-3/4 (196.9)	2001VA42-220	300 (20.7)	18-7/16 (468.3)	7-3/4 (196.9)
			2001VA42-231	300 (20.7)	20-3/8 (517.5)	10-5/8 (269.9)	2001VA42-221	300 (20.7)	19-1/8 (485.8)	10-5/8 (269.9)
1"	17.42	Bronze	2002VA32-230	166 (11.4)	20-3/16 (512.8)	7-3/4 (196.9)	2002VA32-220	192 (13.2)	18-7/8 (479.4)	7-3/4 (196.9)
			2002VA32-231	250 (17.2)	20-13/16 (528.6)	10-5/8 (269.9)	2002VA32-221	250 (17.2)	19-9/16 (496.9)	10-5/8 (269.9)
		316SS	2002VA42-230	166 (11.4)	20-3/16 (512.8)	7-3/4 (196.9)	2002VA42-220	192 (13.2)	18-7/8 (479.4)	7-3/4 (196.9)
			2002VA42-231	300 (20.7)	20-13/16 (528.6)	10-5/8 (269.9)	2002VA42-221	300 (20.7)	19-9/16 (496.9)	10-5/8 (269.9)
1-1/4"	25.30	Bronze	2003VA32-230	98 (6.8)	20-5/16 (515.9)	7-3/4 (196.9)	2003VA32-220	115 (7.9)	19 (482.6)	7-3/4 (196.9)
			2003VA32-231	245 (16.9)	20-15/16 (531.8)	10-5/8 (269.9)	2003VA32-221	250 (17.2)	19-11/16 (500.1)	10-5/8 (269.9)
			2003VA32-233	250 (17.2)	25-13/32 (645.3)	13-3/8 (339.7)	2003VA32-223	250 (17.2)	23-1/8 (587.4)	13-3/8 (339.7)
		316SS	2003VA42-230	98 (6.8)	20-5/16 (515.9)	7-3/4 (196.9)	2003VA42-220	115 (7.9)	19 (482.6)	7-3/4 (196.9)
			2003VA42-231	245 (17.0)	20-15/16 (531.8)	10-5/8 (269.9)	2003VA42-221	300 (20.7)	19-11/16 (500.1)	10-5/8 (269.9)
			2003VA42-233	300 (20.7)	25-13/32 (645.3)	13-3/8 (339.7)	2003VA42-223	300 (20.7)	23-1/8 (587.4)	13-3/8 (339.7)
1-1/2"	32.10	Bronze	2004VA32-230	65 (4.5)	20-11/16 (525.5)	7-3/4 (196.9)	2004VA32-220	80 (5.5)	19-3/8 (492.1)	7-3/4 (196.9)
			2004VA32-231	168 (11.6)	21-5/16 (541.3)	10-5/8 (269.9)	2004VA32-221	235 (16.2)	20-1/16 (509.6)	10-5/8 (269.9)
			2004VA32-233	250 (17.2)	25-25/32 (654.8)	13-3/8 (339.7)	2004VA32-223	250 (17.2)	23-1/2 (596.9)	13-3/8 (339.7)
		316SS	2004VA42-230	65 (4.5)	20-11/16 (525.5)	7-3/4 (196.9)	2004VA42-220	80 (5.5)	19-3/8 (492.1)	7-3/4 (196.9)
			2004VA42-231	168 (11.6)	21-5/16 (541.3)	10-5/8 (269.9)	2004VA42-221	235 (16.2)	20-1/16 (509.6)	10-5/8 (269.9)
			2004VA42-233	300 (20.7)	25-25/32 (654.8)	13-3/8 (339.7)	2004VA42-223	300 (20.7)	23-1/2 (596.9)	13-3/8 (339.7)
2"	50.30	Bronze	2005VA32-230	31 (2.1)	20-15/16 (531.8)	7-3/4 (196.9)	2005VA32-220	44 (3.0)	19-5/8 (498.5)	7-3/4 (196.9)
			2005VA32-231	88 (6.1)	21-9/16 (547.7)	10-5/8 (269.9)	2005VA32-221	140 (9.7)	20-5/16 (515.9)	10-5/8 (269.9)
			2005VA32-233	175 (12.1)	26-1/32 (661.2)	13-3/8 (339.7)	2005VA32-223	250 (17.2)	23-3/4 (603.3)	13-3/8 (339.7)
		316SS	2005VA42-230	31 (2.1)	20-15/16 (531.8)	7-3/4 (196.9)	2005VA42-220	44 (3.0)	19-5/8 (498.5)	7-3/4 (196.9)
2"	50.30	Bronze	2005VA42-231	88 (6.1)	21-9/16 (547.7)	10-5/8 (269.9)	2005VA42-221	140 (9.7)	20-5/16 (515.9)	10-5/8 (269.9)
			2005VA42-233	175 (12.1)	26-1/32 (661.2)	13-3/8 (339.7)	2005VA42-223	272 (18.8)	23-3/4 (606.3)	13-3/8 (339.7)
			2006VA12-233	105 (7.2)	26-1/4 (666.8)	13-3/8 (339.7)	2006VA12-223	190 (13.1)	24-7/16 (620.7)	13-3/8 (339.7)
* 2-1/2"	78.60	Iron	2006VA12-233	105 (7.2)	26-1/4 (666.8)	13-3/8 (339.7)	2006VA12-223	190 (13.1)	24-7/16 (620.7)	13-3/8 (339.7)
		Bronze	2006VA32-233	105 (7.2)	26-1/4 (666.8)	13-3/8 (339.7)	2006VA32-223	190 (13.1)	24-7/16 (620.7)	13-3/8 (339.7)
2-1/2"	78.60		316SS	2006VA42-233	105 (7.2)	26-1/4 (666.8)	13-3/8 (339.7)	2006VA42-223	190 (13.1)	24-7/16 (620.7)

* Valve has flanged connections. Max. USP (PSI) is for Linear Valves. Consult factory for optional trim.

Control Valves - Hi-Flow™ Series, 2-Way, Stocked Models

Pipe Size	Cv 100%	Body Material	Model	Set at USP psig (bar)	Adjustable USP Range psig (bar)
1/2"	6.45	Bronze	2000VA32-230-QS	125 (8.6)	96-200 (6.8-13.8)
3/4"	10.75	Bronze	2001VA32-230-QS	125 (8.6)	81-155 (5.6-10.7)
1"	17.42	Bronze	2002VA32-230-QS	125 (8.6)	123-166 (8.5-11.5)
1"	17.42	Bronze	2002VA32-231-QS	125 (8.6)	71-155 (4.9-10.7)
1-1/4"	25.30	Bronze	2003VA32-230-QS	98 (6.8)	66-98 (4.6-6.8)
1-1/4"	25.30	Bronze	2003VA32-231-QS	125 (8.6)	121-165 (8.3-11.4)
1-1/2"	32.10	Bronze	2004VA32-231-QS	125 (8.6)	104-137 (7.2-9.5)
2"	50.30	Bronze	2005VA32-231-QS	88 (6.1)	68-88 (4.7-6.1)
2"	50.30	Bronze	2005VA32-233-QS	125 (8.6)	116-145 (8.0-10.0)

Filters and Regulators: See pages 527-530

VALVES

Valves, Globe

CONTACT US: U.S. 810-970-8888, U.K. (0144) 101401 101707, U.S. (404) (678) 4070-8855, U.S. (850) 201-0007

1.800.561.8187

www.itm.com

information@itm.com



Hi-Flow[®] Control Valves

3-Way Standard Products for Mixing or Diverting



Caution: Use of an actuator supply gas other than air can create a hazardous environment because a small amount of gas continuously vents to atmosphere

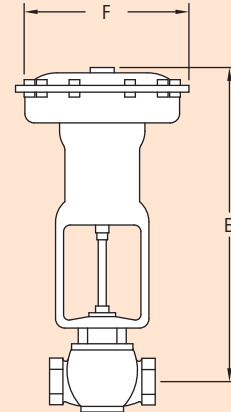

Use the standard models chart to aid in the selection of the most economical Hi-Flow[™] 3-Way Control Valve for your application. Specify maximum upstream pressures (USP's); Mixing: USP_U and USP_L; Diverting: USP_C; based on standard 3-15 psi (.21-1.0 bar) pneumatic control signal.

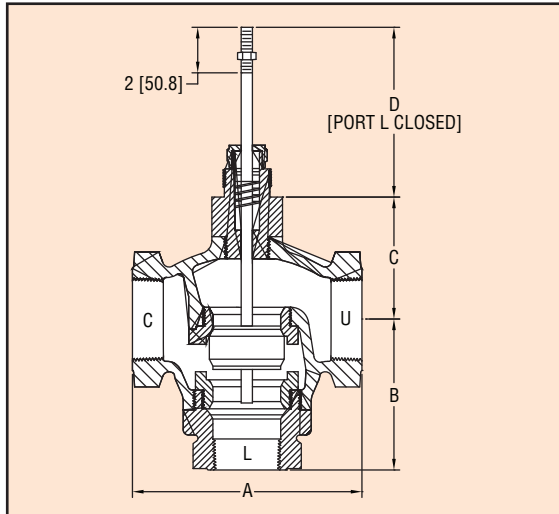

For diverting service, add USP_U and USP_C to determine the shutoff pressure. For mixing service compute: (USP_U - USP_C) + (USP_L - USP_C) to determine the shutoff pressure.

Hi-Flow[™] Control Valves, 3-Way Simplified Selection Guide with Standard Products

Pipe Size	Cv 100%	Body Material	Model	USP(S) PSI (bar)	E in (mm)	F in (mm)
1/2"	6.45	Bronze	3000WA32-220	250 (17.2)	18-1/16 (458.8)	7-3/4 (196.9)
		316SS	3000WA42-220	300 (20.7)	18-1/16 (458.8)	7-3/4 (196.9)
3/4"	10.75	Bronze	3001WA32-220	250 (17.2)	18-1/16 (458.8)	7-3/4 (196.9)
		316SS	3001WA42-220	300 (20.7)	18-1/16 (458.8)	7-3/4 (196.9)
1"	17.42	Bronze	3002WA32-220	200 (13.8)	18-5/16 (465.1)	7-3/4 (196.9)
			3002WA32-221	250 (17.2)	19 (482.6)	10-5/8 (269.9)
		316SS	3002WA42-220	200 (13.8)	18-5/16 (465.1)	7-3/4 (196.9)
			3002WA42-221	300 (20.7)	19 (482.6)	10-5/8 (269.9)
1-1/4"	25.30	Bronze	3003WA32-220	120 (8.4)	18-3/8 (466.7)	7-3/4 (196.9)
			3003WA32-221	250 (17.2)	19-1/16 (484.2)	10-5/8 (269.9)
		316SS	3003WA42-220	120 (8.3)	18-3/8 (466.7)	7-3/4 (196.9)
			3003WA42-221	300 (20.7)	19-1/16 (484.2)	10-5/8 (269.9)
1-1/2"	32.10	Bronze	3004WA32-220	80 (5.6)	18-5/8 (473.1)	7-3/4 (196.9)
			3004WA32-221	200 (13.8)	19-5/16 (490.5)	10-5/8 (269.9)
			3004WA32-223	250 (17.2)	21-3/8 (542.9)	13-3/8 (339.7)
		316SS	3004WA42-220	80 (5.5)	18-5/8 (473.1)	7-3/4 (196.9)
			3004WA42-221	200 (13.8)	19-5/16 (490.5)	10-5/8 (269.9)
			3004WA42-223	300 (20.7)	21-3/8 (542.9)	13-3/8 (339.7)
2"	50.30	Bronze	3005WA32-220	45 (3.1)	19-1/16 (484.2)	7-3/4 (196.9)
			3005WA32-221	100 (6.9)	19-3/4 (501.7)	10-5/8 (269.9)
			3005WA32-223	175 (12.1)	21-13/16 (554.0)	13-3/8 (339.7)
		316SS	3005WA42-220	45 (3.1)	19-1/16 (484.2)	7-3/4 (196.9)
			3005WA42-221	100 (6.9)	19-3/4 (501.7)	10-5/8 (269.9)
			3005WA42-223	175 (12.1)	21-12/16 (554.0)	13-3/8 (339.7)
*2-1/2"	78.6	Iron	3006WA12-223	97 (6.7)	24.52 (622.8)	13-3/8 (339.7)
		Bronze	3006WA32-223	97 (6.7)	24.52 (622.8)	13-3/8 (339.7)

*Valve has flanged connections. Max. USP (PSI) is for Linear Valves. Consult factory for optional trim.

Dimension Data

Pipe Size	B in (mm)	C in (mm)	D in (mm)
1/2"	2-9/16 (65.1)	2-3/16 (55.6)	4-1/8 (104.8)
3/4"	2-9/16 (65.1)	2-3/16 (55.6)	4-1/8 (104.8)
1"	3 (76.2)	2-7/16 (61.9)	4 (101.6)
1-1/4"	3-3/16 (81.0)	2-1/2 (63.5)	3-3/4 (95.3)
1-1/2"	3-3/4 (95.3)	2-3/4 (69.9)	3-11/16 (93.7)
2"	3-15/16 (100.0)	3-3/16 (81.0)	3-11/16 (93.7)

Mixing Service:

FLOW IN - ports U&L
FLOW OUT - port C

Diverting Service:

FLOW IN - port C
FLOW OUT - ports U&L

Standard Models include

LIN-E-AIRE[®] Air-To-Lower Actuator
- port L opens on loss of Air

VALVES

Valves, Globe