

# QuantuMike

## SERIES 293 — Coolant-proof Micrometer

### FEATURES

- Faster measurement with 2mm per revolution instead of the standard 0.5mm.
- A patented ratchet thimble mechanism helps ensure repeatability.
- A function lock helps prevent error.
- IP-65 protection level.
- Certificate of inspection provided.
- With a standard bar except for 0-25mm/0-1" model.
- Supplied in fitted plastic case.



293-180



293-142

### SPECIFICATIONS

Metric			
Range	Resolution	Order No.	Accuracy
0-25mm	0.001mm	<b>293-140</b>	1µm
0-25mm	0.001mm	<b>293-145*</b>	1µm
25-50mm	0.001mm	<b>293-141</b>	1µm
25-50mm	0.001mm	<b>293-146*</b>	1µm
50-75mm	0.001mm	<b>293-142</b>	2µm
50-75mm	0.001mm	<b>293-147*</b>	2µm
75-100mm	0.001mm	<b>293-143</b>	2µm
75-100mm	0.001mm	<b>293-148*</b>	2µm

\* without SPC data output

Inch/Metric			
Range	Resolution	Order No.	Accuracy
0-1"/0 - 25.4mm	.00005"/0.001mm	<b>293-180</b>	.00005"
0-1"/0 - 25.4mm	.00005"/0.001mm	<b>293-185*</b>	.00005"
1-2"/25.4 - 50.8mm	.00005"/0.001mm	<b>293-181</b>	.00005"
1-2"/25.4 - 50.8mm	.00005"/0.001mm	<b>293-186*</b>	.00005"
2-3"/50.8 - 76.2mm	.00005"/0.001mm	<b>293-182</b>	.0001"
2-3"/50.8 - 76.2mm	.00005"/0.001mm	<b>293-187*</b>	.0001"
3-4"/76.2 - 101.6mm	.00005"/0.001mm	<b>293-183</b>	.0001"
3-4"/76.2 - 101.6mm	.00005"/0.001mm	<b>293-188*</b>	.0001"

\* without SPC data output

### DIMENSIONS AND MASS

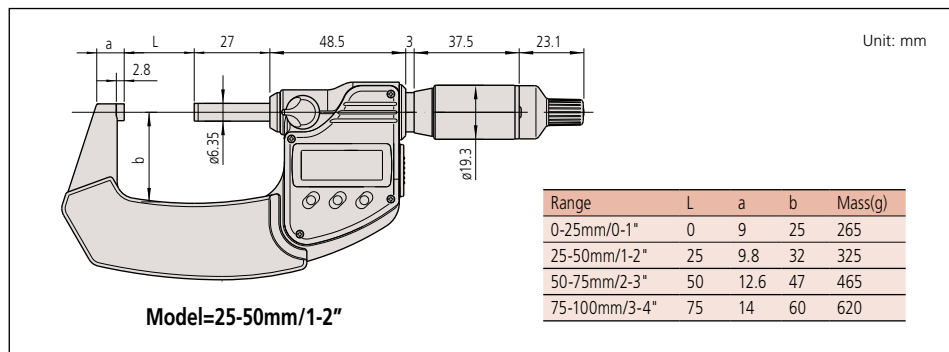

Certificate of inspection

### Technical Data

- Accuracy: Refer to the list of specifications
- Resolution: 0.001mm or .00005"/0.001mm
- Flatness: 0.3µm/.000012"
- Parallelism: 1µm/.00004" for models up to 50mm/2"  
2µm/.00008" for models up to 100mm/4"
- Measuring force: 7-12N
- Measuring faces: Carbide tipped
- Display: LCD
- Battery: SR44 (1 pc.), **938882**
- Battery life: Approx. 1.2 years under normal use  
Dust/Water protection level: IP65

### Function

- Origin-set, Zero / ABS, Hold, Function lock, Auto power on/off, Data output (output models), inch/mm conversion (on inch/metric models only)
- Alarm: Low voltage, Counting value composition error

### Optional Accessories

- 05CZA662:** SPC cable with data switch (1m/40")
- 05CZA663:** SPC cable with data switch (2m/80")



SPC cable with data switch

- 516-529-26** Inspection Gage Block Set  
Rectangular Steel Gage Block  
10 pc. blocks and 1 pc. optical parallel

- 516-319-26** Inspection Gage Block Set  
Rectangular Cera Gage Block  
10 pc. blocks and 1 pc. optical parallel

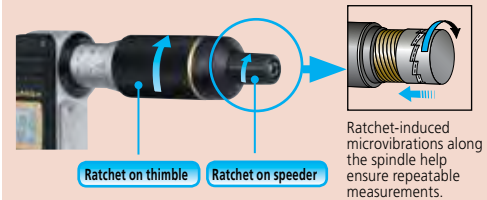

### Significant reduction in positioning time

