



Gems™ Warrick® Series 27 Controls
 Sensors & Controls Installation and Operation Bulletin



This bulletin should be used by experienced personnel as a guide to the installation of series 27. Selection or installation of equipment should always be accompanied by competent technical assistance. We encourage you to contact Gems Sensors or its representative if further information is required.

Important!

Before proceeding to install and wire the control, Read and thoroughly understand these instructions.

***** WARNING:** To prevent ignition of flammable or combustible atmospheres, disconnect power before servicing.

When installing according to these instructions, the sensing circuit is intrinsically safe for Class I, Groups A, B, C and D; Class II, Groups E, F and G; Class III:

Electrical equipment connected to associated apparatus should not exceed maximum voltage marked on product.

Location: The control must be situated in a non-hazardous area where an explosive atmosphere will not exist at any time.

Wiring:

1. Intrinsically safe wiring must be kept separate from non-intrinsically safe wiring.
2. Intrinsically safe and non-intrinsically safe wiring may occupy the same enclosure or raceway if they are at least 2 inches (50mm) apart and separately tied down. Inside panels, field wiring terminals for intrinsically safe circuits must be separated by at least 2 inches (50 mm) from non-intrinsically safe terminals.
3. Wire the control device (s) to the Series 27 relay as shown in the specific application wiring diagram in this bulletin. A separate rigid metallic conduit should be used to enclose the conductors of the intrinsically safe control circuit.
4. An approved seal should be used at the point where the intrinsically safe control circuit wiring enters the hazardous area.

For intrinsically safe output wiring, use #14 or #16 AWG type MTW or THHN wire. By using these wire types in conjunction with the following distance recommendations, you will not exceed the maximum capacitance for field wiring. Use the following chart as a guide for maximum wire runs for differential level service (3wire) field wiring.

Model	Max. Sensitivity (K Ohms)	Distance (FT.)
27XXD0	3	4,000
27XXE0	10	900
27XXH0	24	800
27XXG0	100	75

One of the two grounding terminals provided on the intrinsically safe output terminal strip must be connected as reference to the same conductive media presented to terminals "H" and "L" (*See applicable wiring diagram in this bulletin*) Terminal G *on the supply line/load side* terminal strip is a redundant system ground terminal and should be connected to the earth ground buss of the control's AC supply line feeder.

Note:

1. Intrinsically safe terminals can be connected to any non-energy generating or storing switch device such as a pushbutton, limit or float type switch or any Warrick electrode and fitting assembly.
2. To prevent electrical shock from supply line/load side powered connections, Series 27 should be mounted in a tool accessible enclosure of proper NEMA rated integrity.
3. For additional guidance on "Hazardous Location Installation" and "Intrinsically Safe Devices", consult ANSI/ISA standard RP 12-6 or NEC articles 500-516.

27 - X-X - X-X

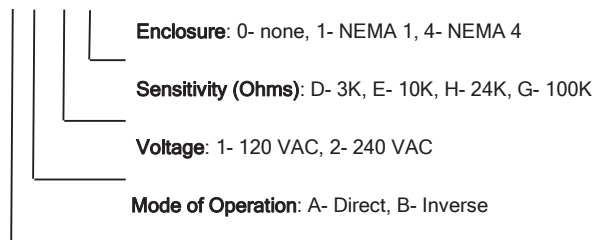

Grounding: Both mounting tabs of the Series 27 provide an electrical connection for earth grounding between the control's internal solid state circuitry and the enclosure chassis. To insure proper grounding, use only metal screws and lock washers when mounting this control.

Contact Design

SPDT (1 form C): One normally open (N.O.) and one normally closed (N.C.), non-powered contacts

Contact Ratings: 8A @ 240 VAC resistive, 8Amps @ 30 VDC resistive

Contact Life

Mechanical: 10 million operations.

Electrical: 100,000 operations minimum at rated load

Electronic Module

Solid state components epoxy encapsulated in a black nylon shell

Supply Voltage

120 or 240 VAC models $\pm 10\%$, 50/60 Hz.

Supply Current

Relays energized - 1.7 VA.

Secondary Circuit

11 VAC RMS voltage on probes, 2.3 milli-amp current

Sensitivity

Models operate from 0-100,000 ohms maximum specific resistance (factory set)

Temperature

-40° to 150° F ambient

Terminals

Size 6 pan head screws with captivated wire clamping plate

Listings

U.L. Intrinsically Safe (UL 913)

Wiring diagram Single Level Service -Conductance Actuated

1. Connect (both terminals AC, AC) and G to appropriate VAC supply line.
2. Install metallic jumper between terminal H and L.
3. Connect terminal L to the electrode.

Terminal G must be grounded to the tank if metallic. When the tank is non-metallic, terminal G must be connected to an additional electrode of length equal to the longest electrode.

4. Wire contacts (C-NO) normally open and (C-NC) normally closed into load circuit as required.

Note: Jumper must be installed as shown to insure proper Operation.

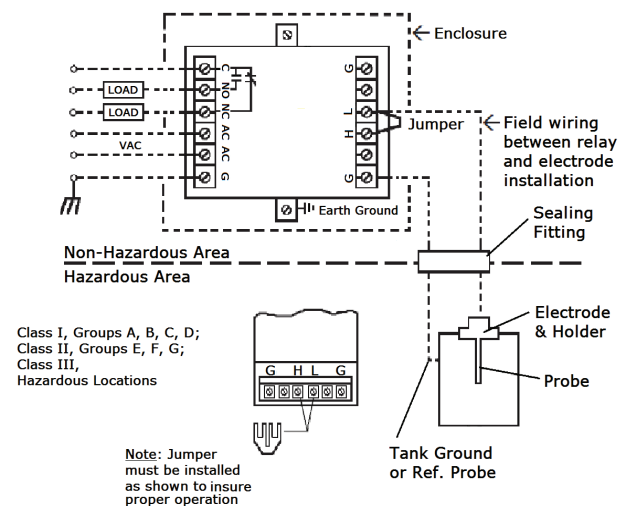

Wiring diagram Differential Level Service -Conductance Actuated

1. Connect (both terminals AC, AC) and G to appropriate VAC supply line.
2. Connect terminal H to the electrode and terminal L to low electrode.

Terminal G must be grounded to the tank if metallic. When the tank is non-metallic, terminal G must be connected to an additional electrode of length equal to the longest electrode.

3. Wire contacts (C-NO) normally open and (C-NC) normally closed into load circuit as required.

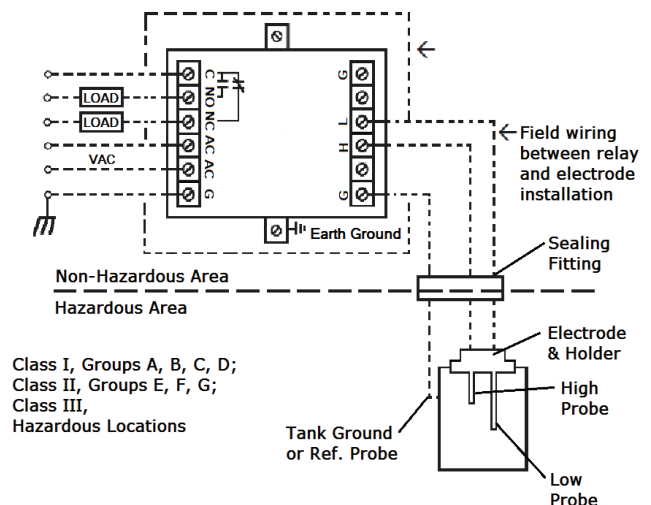

Wiring diagram
Single Input (Non Latching)
-Pilot Contact Actuated

1. Connect (both terminals AC, AC) and G to appropriate VAC supply line.
2. Install metallic jumper between terminal H and L.
3. Wire contacts (C-NO) normally open and (C-NC) normally closed into load circuit as required.
4. Connect the pilot contact to terminals G and L.

Note: Jumper must be installed as shown to insure proper Operation.

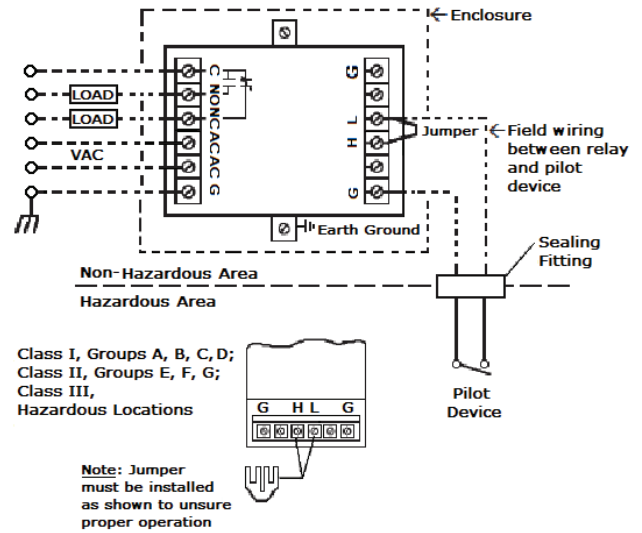

Wiring diagram
Dual Input Latching
-Pilot Contact Actuated

1. Connect (both terminals AC, AC) and G to appropriate VAC supply line.
2. Wire contacts (C-NO) normally open and (C-NC) normally closed into load circuit as required.
3. Connect the latch pilot contact to terminals G and H and the unlatch Pilot contact to terminal G and L.

