

- CLAMP-ON METER
- MEDIDORES DE TENAZA

511
512

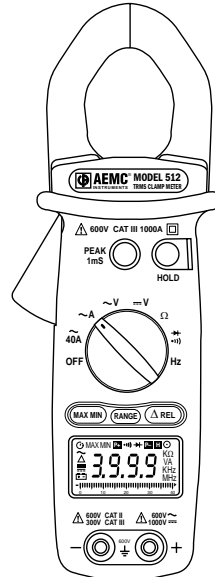

ENGLISH User Manual
ESPAÑOL Manual de Instrucciones



Statement of Compliance

Chauvin Arnoux®, Inc. d.b.a. AEMC® Instruments certifies that this instrument has been calibrated using standards and instruments traceable to international standards.

We guarantee that at the time of shipping your instrument has met its published specifications.

An NIST traceable certificate may be requested at the time of purchase, or obtained by returning the instrument to our repair and calibration facility, for a nominal charge.

The recommended calibration interval for this instrument is 12 months and begins on the date of receipt by the customer. For recalibration, please use our calibration services. Refer to our repair and calibration section at

Serial #: _____

Catalog #: 2117.67 / 2117.68

Model #: 511/512

Please fill in the appropriate date as indicated:

Date Received: _____

Date Calibration Due: _____



Chauvin Arnoux®, Inc. d.b.a AEMC® Instruments

Table of Contents

ENGLISH	1
ESPAÑOL.....	25
1. INTRODUCTION	3
1.1 International Electrical Symbols.....	4
1.2 Receiving Your Shipment.....	4
1.3 Ordering Information	4
1.3.1 Replacement Parts.....	4
2. PRODUCT FEATURES	5
2.1 Description	5
2.2 Model 511/512 Control Features.....	6
2.3 LCD Display	7
3. SPECIFICATIONS	8
3.1 Electrical Specifications	8
3.2 Mechanical Specifications.....	9
3.3 Environmental Specifications	10
3.4 Safety Specifications.....	10
4. OPERATION	11
4.1 Button Functions	11
4.1.1 Data Hold	11
4.1.2 Peak Hold Function	11
4.1.3 MAX/MIN Function	12
4.1.4 REL Function.....	12
4.1.5 Manual Range Mode.....	12
4.2 AC Current Measurement	13
4.3 AC Volt Measurement	14
4.4 DC Volt Measurement.....	15
4.5 Resistance Measurement	16

4.6	Continuity Measurement	17
4.7	Diode Measurement.....	18
4.8	Frequency Measuring - Voltage	19
4.9	Frequency Measurement - Current....	20
5.	MAINTENANCE	21
5.1	Warning!.....	21
5.2	Cleaning.....	21
5.3	Battery Replacement.....	22
	Repair and Calibration.....	23
	Technical and Sales Assistance	23
	Limited Warranty	24
	Warranty Repairs.....	24

CHAPTER 1

INTRODUCTION

 **Warning** 

- Read the user manual before operating and follow all safety information.
- Only use the meter as specified in this user manual.
- Never use this meter on a circuit with voltages greater than 600Vrms @ 50/60 Hz, Cat. III or 750V, Cat. II.
- Never measure current while the test leads are connected to the input jacks.
- Do not operate the meter if the body or test leads look damaged.
- Check the rotary range switch and make sure it is at the correct position before each measurement.
- Do not perform resistance and continuity test on a live circuit.
- Use extreme caution when measuring live systems with voltages greater than 60VDC or 30VAC.
- Use extreme care when working around bus bars and bare conductors.
- Do not use the meter in over range/overload conditions (OL).
- For accurate readings, change the battery when the  symbol appears.

1.1 International Electrical Symbols



This symbol signifies that the instrument is protected by double or reinforced insulation.



This symbol on the instrument indicates a WARNING and that the operator must refer to the user manual for instructions before operating the instrument. In this manual, the symbol preceding instructions indicates that if the instructions are not followed, bodily injury, installation/sample and product damage may result.



Risk of electric shock. The voltage at the parts marked with this symbol may be dangerous.

1.2 Receiving Your Shipment

Upon receiving your shipment, make sure that the contents are consistent with the packing list. Notify your distributor of any missing items. If the equipment appears to be damaged, file a claim immediately with the carrier and notify your distributor at once, giving a detailed description of any damage. Save the damaged packing container to substantiate your claim.

1.3 Ordering Information

Clamp-on Meter Model 511 Cat. #2117.67

Includes meter, pair of test leads (red/black with probe tips), one 9V battery, soft carrying case and a user manual.

TRMS Clamp-on Meter Model 512..... Cat. #2117.68

Includes meter, pair of test leads (red/black with probe tips), one 9V battery, soft carrying case and a user manual.

1.3.1 Accessories and Replacement Parts

Set of 2, 5 ft color-coded leads..... Cat. #2154.74

Replacement Pouch Cat. #2118.94

PRODUCT FEATURES

2.1 Description

The AEMC® Models 511 and 512 are general purpose professional clamp-on meters that measure up to the toughest standards. These meters offer a complete set of measurement ranges (AC Amps, AC Volts, DC Volts, Ohms, Continuity with beeper, Frequency from V or A, Diode Test function) and are in compliance with international safety and quality standards to ensure professional and reliable measuring tools. They are Auto-Ranging and provide the best measurement range and resolution for troubleshooting. They also have a high resolution 40A range.

The Models 511 and 512 are sized for comfortable, one-handed operation. The tapered and hooked jaw design facilitates maneuvering in crowded wiring and breaker panels, making it easy to select conductors. The jaw opening accommodates one 750kcmil cable or two 350kcmil cables. The large and easy-to-read 4000-count LCD features comprehensive user information symbols, such as low battery, polarity, overload, and an analog bargraph for easy trend readings. Both models are equipped with a Data Hold function that freezes the measurement for later viewing, Min/Max, and a fast 1ms Peak Hold function for capture of signals.

The Model 511 is average sensing and designed for traditional average responding electrical systems. The Model 512 is a True RMS clamp-on that provides RMS measurements for today's non-linear electrical environments.

2.2 Model 511/512 Control Features

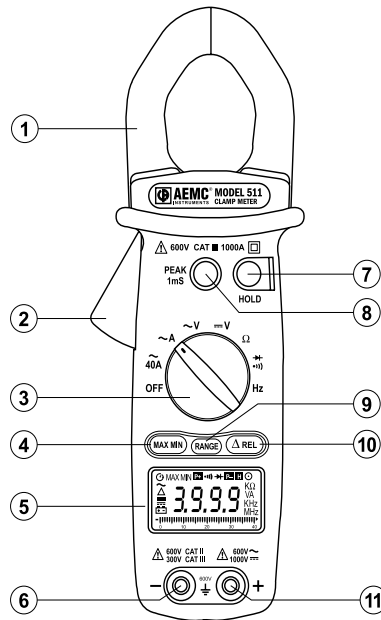

1. Jaw Assembly - 1.575" (40 mm)
2. Lever for Jaw Opening/Closing
3. Rotary Range Selector Switch
4. Maximum/Minimum Button
5. LCD Display
6. COM (black) Input
7. Data Hold Button
8. Peak Hold Button
9. Range Button
10. Relative Button
11. Positive (red) Input

2.3 LCD Display

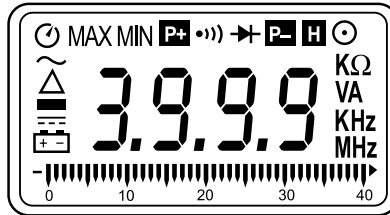

	Low Battery
	DC Input
	Polarity Indicator
	Zero (Relative)
	AC Input
	Auto Power Off Indication
	Positive Peak Detect Indication
	Continuity Beeper Enabled
	Diode Function Indication
	Negative Peak Detect Indication
	Data Hold
	Manual Range
KΩ	Resistance Measurement Indicator
VA	Voltage/Current Indicator
KHz / MHz	Frequency Measurement Indicator
	Analog Bargraph

CHAPTER 3

SPECIFICATIONS

3.1 Electrical Specifications

Reference Conditions: 23°C ±5°C, 45 to 80% RH, True RMS for VAC and AAC accuracy are specified from 5% to 100% of range, crest factor 1.4 < CF < 3 at full scale & CF < 6 at half scale.

AC Amperes (Auto-Ranging)

Range	Resolution	Accuracy (50/500Hz)	Overload
40A	0.01A	1.9% Reading ± 5cts	800 Arms
400A	0.1A		1500Arms
1000A	1A		

AC Volts (Auto-Ranging)

Range	Resolution	Accuracy (50/500Hz)	Overload
400V	0.1V	1.2% Reading ± 5cts	1000Vrms
750V	1V		

DC Volts (Auto-Ranging)

Range	Resolution	Accuracy (50/500Hz)	Overload
400V	0.1V	0.75% Reading ± 2cts	1200Vrms
1000V	1V		

Resistance - Ohms (Ω)

Range	Resolution	Accuracy (50/500Hz)	Overload
400Ω	0.1Ω	1% Reading ± 2cts	600Vrms
4000Ω	1Ω		

Diode ()

Range	Active Region	Overload Protection
	0.6mA	600Vrms

NOTE: Model 511 is average sensing
Model 512 is TRMS

Continuity ()

Range	Beeper Activation	Overload
	< 40Ω	600Vrms

Frequency (Hz) (Auto Ranging)

Function	Range	Resolution	Sensitivity	Accuracy
A - Hz	4K	1Hz	2Arms	0.1% of Reading ± 1cts
V - Hz	4K, 10K	1Hz	5Vrms	

3.2 Mechanical Specifications

Digital Display:

3 3/4 digits LCD display (max reading 3999)

Analog Display:

Fast 42 segment analog bargraph display

Symbol and Scale Range:

Automatic according to range and input signal

Polarity:

 displayed when negative signal applied to input

Over Load:

 displayed when input signal exceeds range

Sample Rate:

2 samples/sec for the digital display
20 samples/sec for the analog bargraph

Power Supply:

9V, NEDA 1604 (6LR61) alkaline battery

Low Battery Indication:  displayed when the battery is below the required voltage

Battery Life: Model 511: 150 hours approx
Model 512: 120 hours approx

Auto-Power Off:

The meter will power itself OFF if there is no push button or rotary switch operation for 30 minutes. To deactivate this function, press the "MAX/MIN" button and keep it pressed down, then power up the probe.

Jaw opening size:

1.575" (40mm)

Dimension (L x W x D):

9.53 x 2.60 x 1.42" (242 x 66 x 36mm)

Weight: 14.10 oz (400g) with batteries

3.3 Environmental Specifications

Altitude: 2000 meters

Operating Temperature:

32° to 104°F (0° to 40°C) < 80% RH, non-condensing

Storage Temperature:

14° to 140°F (-10° to 60°C) < 70% RH, battery removed

3.4 Safety Specifications

EN61010 600V CAT III, Pollution Degree: 2

EN61010 1000V CAT II, Pollution Degree: 2



**Specifications are subject to change without notice*

CHAPTER 4

OPERATION

4.1 Button Functions

4.1.1 Data Hold

- The last reading may be held on the display by pressing the HOLD button. The **H** symbol will be displayed in data hold mode.
- When the held data is no longer needed, release the hold function by pressing the HOLD button again.

4.1.2 Peak Hold Function

- The Models 511 and 512 are built with 1ms peak hold function on AAc, VAc and Vdc ranges.
- Calibration is necessary before performing a peak hold operation.
- To start the calibration process, press and hold the PEAK button for 2 seconds. "CAL" will display on the LCD and the offset will be calculated and kept in the meter.
- After calibration, choose either **P+** or **P-** by pressing the Peak Hold button to keep the peak reading.
- Pressing the PEAK button for 2 seconds will return the meter back to normal operation.
- Once the function range is changed, the meter will need another calibration for peak measurement.

4.1.3 MAX/MIN Function

- The Models 511 and 512 are built with MAX/MIN function at AAC, VAC and VDC ranges.
- Pressing the MAX/MIN button once will set the meter to MAX mode.
- Pressing it twice will set the meter to MIN mode.
- Pressing it three times will display the present reading and still keep track of the MAX and MIN change. This mode will also indicate a blinking MAX/MIN symbol.
- Pressing the MAX/MIN button for more than 2 seconds will set the meter back to normal operation.

4.1.4 REL Function

- The Models 511 and 512 are built with REL function at AAC, VAC and VDC ranges.
- Pressing the Δ REL button once will change the zero to the present reading and the relative value will show on the LCD.
- Pressing it twice will display the relative zero point. This mode will also indicate a blinking Δ symbol.
- Pressing the Δ REL button for more than 2 seconds will set the meter back to normal operation.

4.1.5 Manual Range Mode

- The Models 511 and 512 operate in an Auto-ranging mode (AUTO displayed) by default. Manual-ranging in VAC/DC, and A (1000A) is available.
- Press and hold the RANGE button. When the range changes (decimal point shift), release the button.
- The \odot symbol is displayed in the manual range mode.
- Press and hold the RANGE button for more than 2 seconds to re-enter the Auto-ranging mode.

4.2 AC Current Measurement

NOTE: Remove the test leads before measuring current

- Turn the rotary range switch to the \tilde{A} range.
- Press the lever to open the jaws.
- Clamp the jaws around the conductor to be measured.
- If reading is unstable and is hard to read, push the **HOLD** button and read the measurement.



WARNING: If overload "OL" is displayed, unclamp the meter immediately .

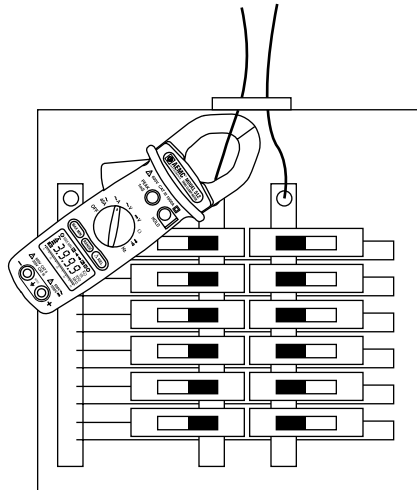

4.3 AC Volt Measurement



WARNING: Maximum Input Voltage is 600V. Do not exceed this voltage to avoid electrical shock and/or damage to the instrument.

- Turn the rotary range switch to the \tilde{V} range.
- Insert the red test lead to the red "+" input jack and the black lead to the black "COM" input jack.
- Bring the test probe tips into contact with the test points.
- If reading is unstable and is hard to read, push the **HOLD** button and read the measurement.



WARNING: Immediately unclamp the meter from the conductor under test if overload "OL" is displayed.

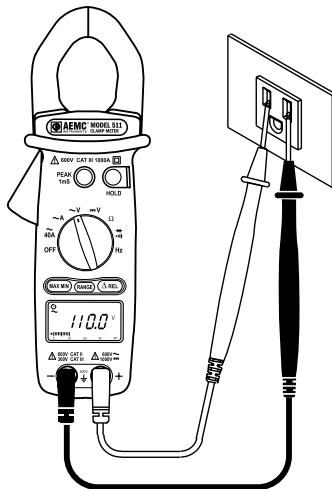

4.4 DC Volt Measurement

- Turn the rotary range switch to the \overline{V} range.
- Insert the red test lead to the red "+" input jack and the black lead to the black "COM" input jack.
- Bring the test probe tips into contact with the test points.
- If reading is unstable and is hard to read, push the **HOLD** button and read the measurement.



WARNING: Immediately unclamp the meter from the conductor under test if overload "OL" is displayed.

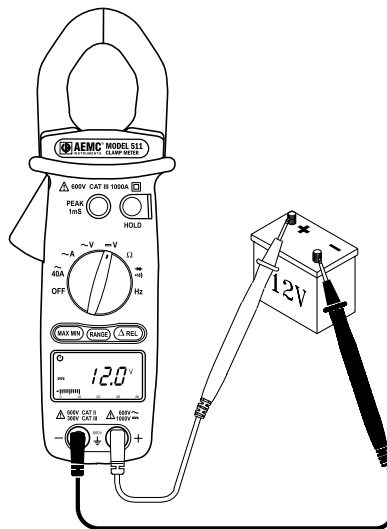

4.5 Resistance Measurement

- Turn the rotary range switch to the Ω range.
- Insert the red test lead to the red "+" input jack and the black lead to the black "COM" input jack.
- Bring the test probe tips into contact with the sample under test.



WARNING: Immediately unclamp the meter from the conductor under test if overload "OL" is displayed.



WARNING: When making a resistance measurement, make sure that the power is off (dead circuit), and that all capacitors in the measured circuit are fully discharged.

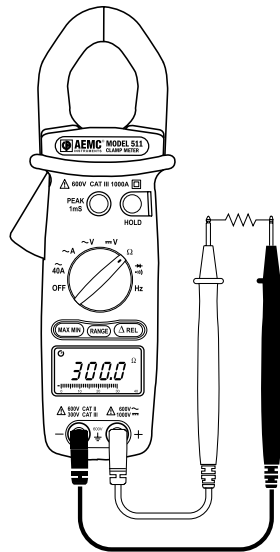

4.6 Continuity Measurement



WARNING: When testing continuity, make sure that there is no power in the tested sample or circuit (dead circuit). This may be checked by using the voltage functions.

- Turn the rotary range switch to the Ω range.
- Insert red test lead to the red "+" input jack and the black lead to the black "COM" input jack.
- Bring the test probe tips into contact with the sample under test.
- If the resistance is less than 40Ω , the beeper emits a continuous sound.



WARNING: Immediately unclamp the meter from the conductor under test if overload "OL" is displayed.

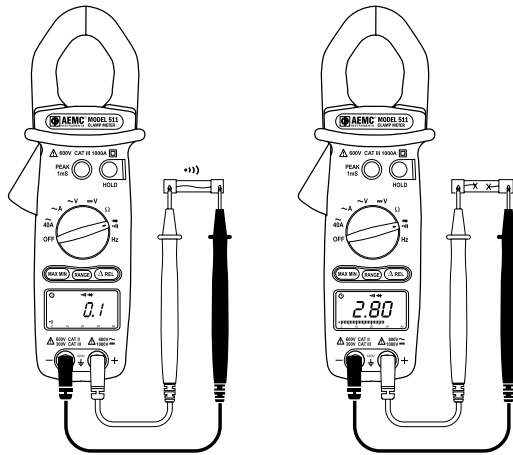

Clamp-on Meter Models 511 and 512

4.7 Diode Measurement



WARNING: Make sure that there is no power in the tested sample or circuit (dead circuit).

- Turn the rotary range switch to the **▶+••|)** range.
- Insert red test lead to the red “+” input jack and the black lead to the black “COM” input jack.
- Bring the test probe tips into contact with the sample under test.
- If the polarity of the test leads are reversed with diode polarity, the digital reading shows ≥ 3.0 . This can be used for distinguishing anode and cathode terminals of a diode.

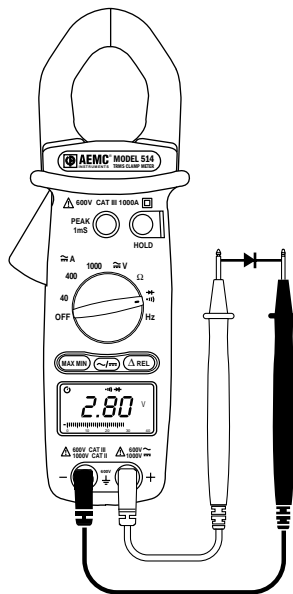

4.8 Frequency Measuring Using Voltage Input

- Turn the rotary range switch to the **Hz** range.
- Insert red test lead to the red "+" input jack and the black lead to the black "**COM**" input jack.
- Bring the test probe tips into contact with the sample under test.



WARNING: Immediately unclamp the meter from the conductor under test if overload "OL" is displayed.

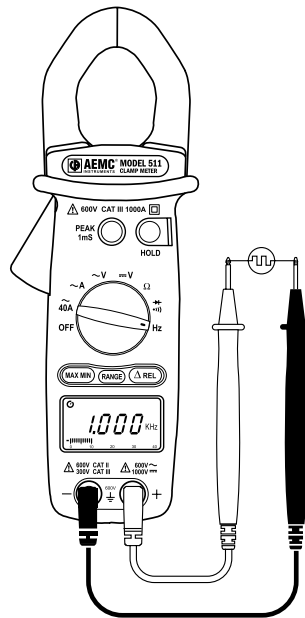

4.9 Frequency Measurement Using Current Input

NOTE: Remove the test leads before measuring current

- Turn the rotary range switch to the **Hz** range.
- Press the lever to open the jaws.
- Clamp the jaws around the conductor to be measured.



WARNING: Do not use both voltage and current inputs at the same time when measuring frequency. This may be dangerous. Erroneous readings will occur if both inputs are used at the same time.

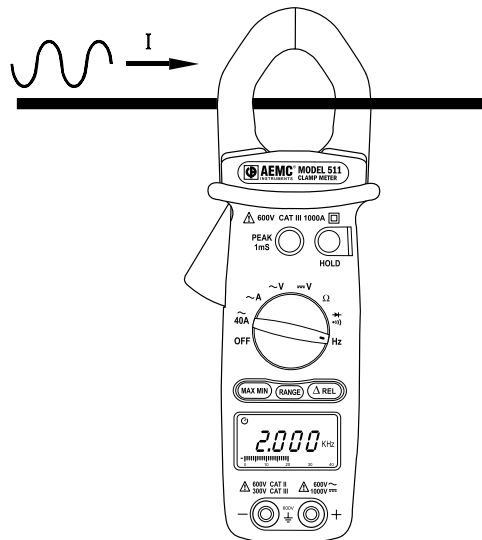

CHAPTER 5

MAINTENANCE

5.1 Warning!

- Remove the test leads on any input before opening the case.
- Do not operate the clamp-on probe without a battery case cover.
- To avoid electrical shock, do not attempt to perform any servicing unless you are qualified to do so.
- To avoid electrical shock and/or damage to the instrument, do not get water or other foreign agents into the probe.

5.2 Cleaning

- To clean the probe, wipe the case with a damp cloth and mild detergent.
- Do not use abrasives or solvents.
- Do not get water inside the case. This may lead to electrical shock or damage to the instrument.

5.3 Battery Replacement

- The Clamp-on Meter Models 511 and 512 are powered by a 9V battery. The  symbol will appear on the LCD display when the supply voltage drops below proper operating range. This indicates that the battery needs to be changed.

- The meter must be in the OFF position and disconnected from any circuit or input.
- Place the meter face down and loosen the battery cover screw with a flat head screwdriver.
- Replace the old battery with a new 9V battery.
- Replace the battery compartment cover and tighten down the screw.

Repair and Calibration

To ensure that your instrument meets factory specifications, we recommend that it be submitted to our factory Service Center at one-year intervals for recalibration, or as required by other standards or internal procedures.

For instrument repair and calibration:

You must contact our Service Center for a Customer Service Authorization Number (CSA#). This will ensure that when your instrument arrives, it will be tracked and processed promptly. Please write the CSA# on the outside of the shipping container. If the instrument is returned for calibration, we need to know if you want a standard calibration, or a calibration traceable to N.I.S.T. (Includes calibration certificate plus recorded calibration data).

Chauvin Arnoux®, Inc. d.b.a. AEMC® Instruments

(Or contact your authorized distributor)

Costs for repair, standard calibration, and calibration traceable to N.I.S.T. are available.

NOTE: A CSA# must be obtained before returning any instrument.

Technical and Sales Assistance

If you are experiencing any technical problems, or require any assistance with the proper operation or application of your instrument, please call, mail, fax or e-mail our technical support hotline:

Chauvin Arnoux®, Inc. d.b.a. AEMC® Instruments

NOTE: Do not ship instruments to our Foxborough, MA address.

Limited Warranty

The Models 511 and 512 are warranted to the owner for a period of two years from the date of original purchase against defects in manufacture. This limited warranty is given by AEMC® Instruments, not by the distributor from whom it was purchased. This warranty is void if the unit has been tampered with, abused or if the defect is related to service not performed by AEMC® Instruments.

For full warranty coverage detail and registration, go to

What AEMC® Instruments will do: If a malfunction occurs within the warranty period, you may return the instrument to us for repair or replacement free of charge, provided we have your registration information on file or proof of purchase. AEMC® Instruments will, at its option, repair or replace the faulty material.

REGISTER ONLINE AT:

Warranty Repairs

What you must do to return an Instrument for Warranty Repair:

First, request a Customer Service Authorization Number (CSA#) by phone or by fax from our Service Department (see address below), then return the instrument along with the signed CSA Form. Please write the CSA# on the outside of the shipping container. Return the instrument, postage or shipment pre-paid to:

Chauvin Arnoux®, Inc. d.b.a. AEMC® Instruments

Caution: To protect yourself against in-transit loss, we recommend you insure your returned material.

NOTE: All customers must obtain a CSA# before returning any instrument.