

# PH-A14

# Profile Projector

## User's Manual

Read this User's Manual thoroughly  
before operating the instrument. After reading,  
retain it close at hand for future reference.

# Mitutoyo

---

# Conventions Used in this User's Manual

---

This section describes the symbols (safety alert symbols) used in this manual.

## Safety Precautions

This manual uses various symbols to help you use this instrument correctly, and prevent danger to personnel or equipment damage.

- The following symbols indicate general dangers, warnings and cautions.



Indicates an imminently hazardous situation which, if not avoided, will result in serious injury or death.

---



Indicates a potentially hazardous situation which, if not avoided, will result in serious injury or death.

---



Indicates a potentially hazardous situation which, if not avoided, may result in minor or moderate injury or property damage.

---

- The following symbols indicate specific warnings or prohibited actions.



Alerts the user to a specific hazardous situation. The given example means "Caution, risk of electric shock".

---



Prohibits a specific action. The given example means "Do not disassemble".

---

---

# Conventions Used in this User's Manual

---

## On Various Types of Notes

The following types of notes are used in this manual to help the user operate this instrument correctly and obtain precise images.

---

### Important

- An *important note* is a type of note that provides information essential to the completion of a task. You cannot disregard this note to complete a task.
  - Information that, if disregarded, could result in a loss in performance, or make it difficult to maintain performance.
- 

### Note

A *note* emphasizes or supplements important points in the main text. A note supplies information that may only apply in special cases.

---

### Tip

A *tip* is a type of note helps the user apply the techniques and procedures described in the text to their specific needs. It also provides reference information associated with the topic being discussed.

---

Mitutoyo assumes no liability to any party for any loss or damage, direct or indirect, caused by use of this instrument not conforming to this manual.

Information in this document is subject to change without notice.

© Copyright Mitutoyo Corporation. All rights reserved.

# Handling precautions

1. **Operation manual**

To obtain the best possible performance and long service life from your Mitutoyo Profile Projector P H-A 1 4, please read this User's Manual carefully prior to setup and operation.
2. **Handling**

Since the P H-A 1 4 Profile Projector incorporates high precision components of large weight, take special care so that no part of the projector is subjected to impact or excessive force when it is being installed, set up or operated.

Use the carrying handles on both sides of the projector to lift or carry the Profile Projector during unpacking and setting up. Never apply pressure to the control panel, microstage or other important parts.
3. **Installation site**

Select a location where the Profile Projector is not exposed to extreme temperatures, sudden temperature changes, high humidity, oil, direct sunlight, or vibration.

In addition, the machine should be placed on a rigid stand. Although a dark setup location is not required, take care to shield the projection screen from direct light.
4. **Power source/grounding**

A single-phase power supply must be used with the Profile Projector. Only allow the power outlet at the installation site to be used for the P H-A 1 4 Profile Projector. Do not share the outlet with other electric equipment.
5. **Replacement parts**

Use only the specified fuse and lamp, and follow the procedures described in this manual. Never attempt to remove the cover/panel or disassemble components except for those parts associated with consumable item replacement. This could cause machine failure or produce low-quality images.
6. **Dust and dirt protection for the lens**

Never touch the lens, mirror, or bulb in order to avoid fingerprints, dust or oil.

Ensure that these optical parts are always kept clean. Refer to "4.1 Maintenance of Optical Components for proper lens maintenance".

## Warranty

This instrument has been manufactured under Mitutoyo's rigorous quality control system. In the event that it proves defective in workmanship or materials within one year from the date of purchase under normal usage, Mitutoyo will repair the instrument free of charge. Contact your dealer or nearest Mitutoyo Service Center.

This warranty does not apply to the following cases:

- Equipment failure or damage due to incorrect usage or unauthorized modification or repair.
- Equipment failure or damage resulting from moving, transporting, or dropping the instrument.
- Equipment failure or damage due to fires, salt damage, gas damage, abnormal voltages, or natural disasters.

# Contents

|   |     |
|---|-----|
| <b>Conventions Used in this User's Manual</b> .....                 | i   |
| <b>Safety Precautions</b> .....                                     | i   |
| <b>On Various Types of Notes</b> .....                              | ii  |
| <b>Handling precautions</b> .....                                   | iii |
| <b>Warranty</b> .....   | iii |
| <b>Contents</b> .....   | iv  |
| <br>  |     |
| <b>1. Overview</b> .....  | 1-1 |
| 1.1 Outline .....   | 1-1 |
| 1.2 System Configuration .....                                      | 1-1 |
| 1.3 Name of Each Part .....   | 1-2 |
| 1.3.1 System appearance .....                                       | 1-2 |
| <br>  |     |
| <b>2. Setup</b> .....   | 2-1 |
| 2.1 Unpacking .....   | 2-1 |
| 2.2 Installation .....  | 2-2 |
| 2.2.1 Environmental condition .....                                 | 2-2 |
| 2.2.2 Transportation and installation .....                         | 2-3 |
| 2.3 Attach the screen glass .....                                   | 2-4 |
| 2.4 Mounting the Lens .....   | 2-5 |
| 2.5 Setting-up the Power Supply .....                               | 2-5 |
| 2.6 Checking the Magnification Accuracy .....                       | 2-6 |
| <br>  |     |
| <b>3. Operation</b> .....   | 3-1 |
| 3.1 Positioning the Workpiece .....                                 | 3-1 |
| 3.2 Projecting Methods .....  | 3-2 |
| 3.2.1 Projection by contour illumination .....                      | 3-2 |
| 3.2.2 Projection by surface illumination .....                      | 3-2 |
| 3.2.3 Projection by contour and surface illumination .....          | 3-2 |
| 3.3 General Measurement and Inspection .....                        | 3-3 |
| 3.3.1 Dimensional measurement using a scale .....                   | 3-3 |
| 3.3.2 Comparison with an overlay chart .....                        | 3-3 |
| 3.3.3 Measurement using an external counter/2D data processor ..... | 3-4 |

|  |            |
|--|------------|
| <b>4. Maintenance</b> .....                            | <b>4-1</b> |
| 4.1 Maintenance of Optical Components .....            | 4-1        |
| 4.1.1 Projection lens and condenser lens .....         | 4-1        |
| 4.1.2 Mirror (surface reflection mirror) .....         | 4-1        |
| 4.1.3 Screen glass .....                               | 4-1        |
| 4.2 Maintenance of Mechanical Components .....         | 4-1        |
| 4.2.1 Projector main unit .....                        | 4-1        |
| 4.2.2 Microstage .....                                 | 4-1        |
| 4.3 Replacing Consumable Parts .....                   | 4-2        |
| 4.3.1 Fuse .....                                       | 4-2        |
| 4.3.2 Bulbs for contour and surface illuminators ..... | 4-2        |
| 4.3.3 Periodic inspection .....                        | 4-2        |
| 4.3.4 List of parts for maintenance .....              | 4-2        |
| <b>5. Troubleshooting</b> .....                        | <b>5-1</b> |
| 5.1 Problems on the Power Supply .....                 | 5-1        |
| 5.2 Problems on the Operation .....                    | 5-2        |
| <b>6. Specifications</b> .....                         | <b>6-1</b> |
| 6.1 Main Unit .....                                    | 6-1        |
| 6.2 Projection Specifications .....                    | 6-2        |
| 6.3 Accessories .....                                  | 6-3        |
| 6.3.1 Standard accessories .....                       | 6-3        |
| 6.3.2 Optional accessories .....                       | 6-3        |
| 6.4 External Dimensions .....                          | 6-5        |

## **SERVICE NETWORK**

# 1

## Overview

This chapter describes the configuration of the Profile Projector PH-A14. The name and function of each part are also given here.

### 1.1 Outline

The Mitutoyo Profile Projector PH-A14 is an advanced piece of instrumentation used to project a workpiece surface or contour on a screen for dimensional measurements and observation.

This instrument provides the following features:

- The PH-A14 is a bench-type profile projector which has a protractor screen with an effective diameter of 356mm and a horizontal light axis.
- Four types of high-performance projection lenses are available at 10x (standard accessory), 20x, 50x, and 100x magnifications (magnifications over 10x are optional).
- The microstage has a large loading capacity that enables a heavy workpiece, such as a formed cutter, hob-gear, large screw threads, and cutters, to be measured.
- A long list of accessories facilitates easy workpiece set-up and enhances measurement efficiency.
- The twin fiber illumination unit is provided as standard. It is suitable for spotlighting.

### 1.2 System Configuration

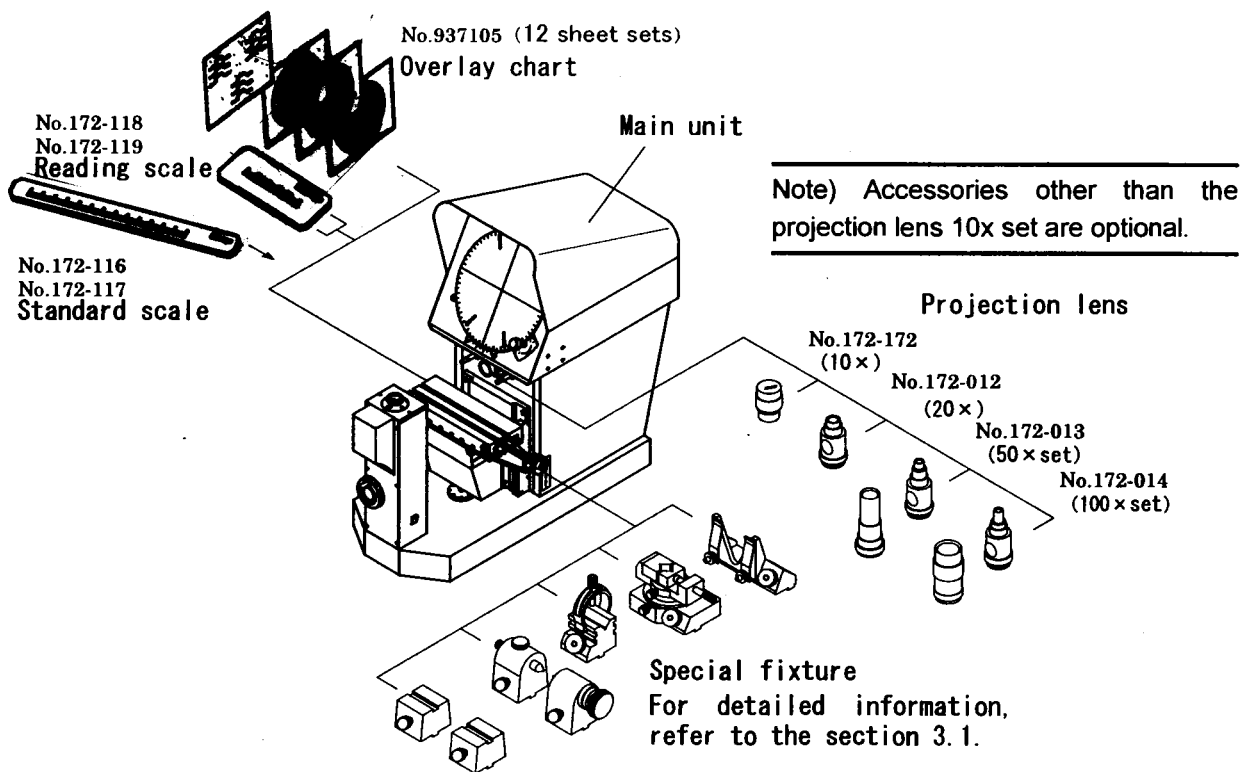

# 1.3 Name of Each Part

## 1.3.1 System appearance

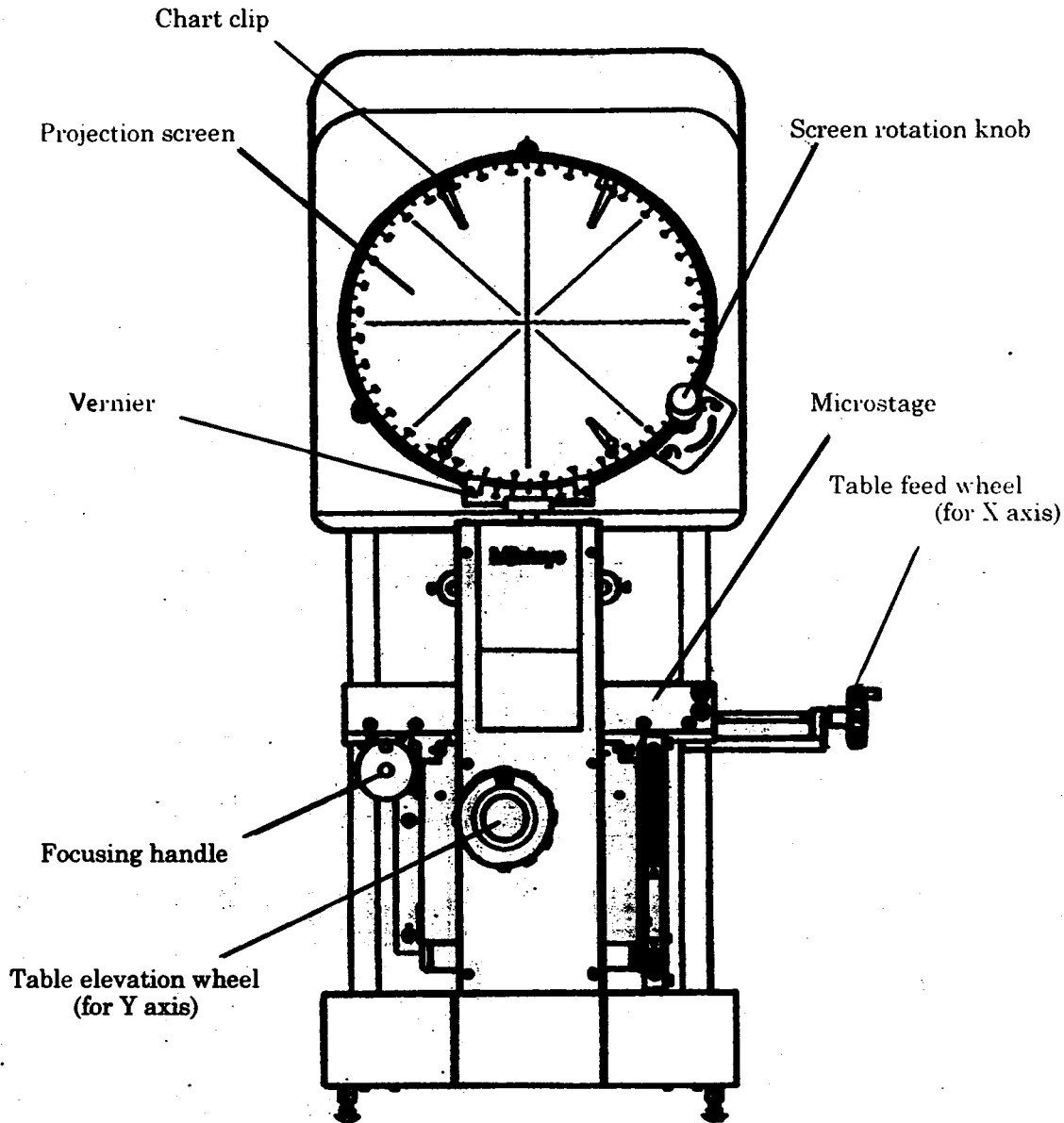

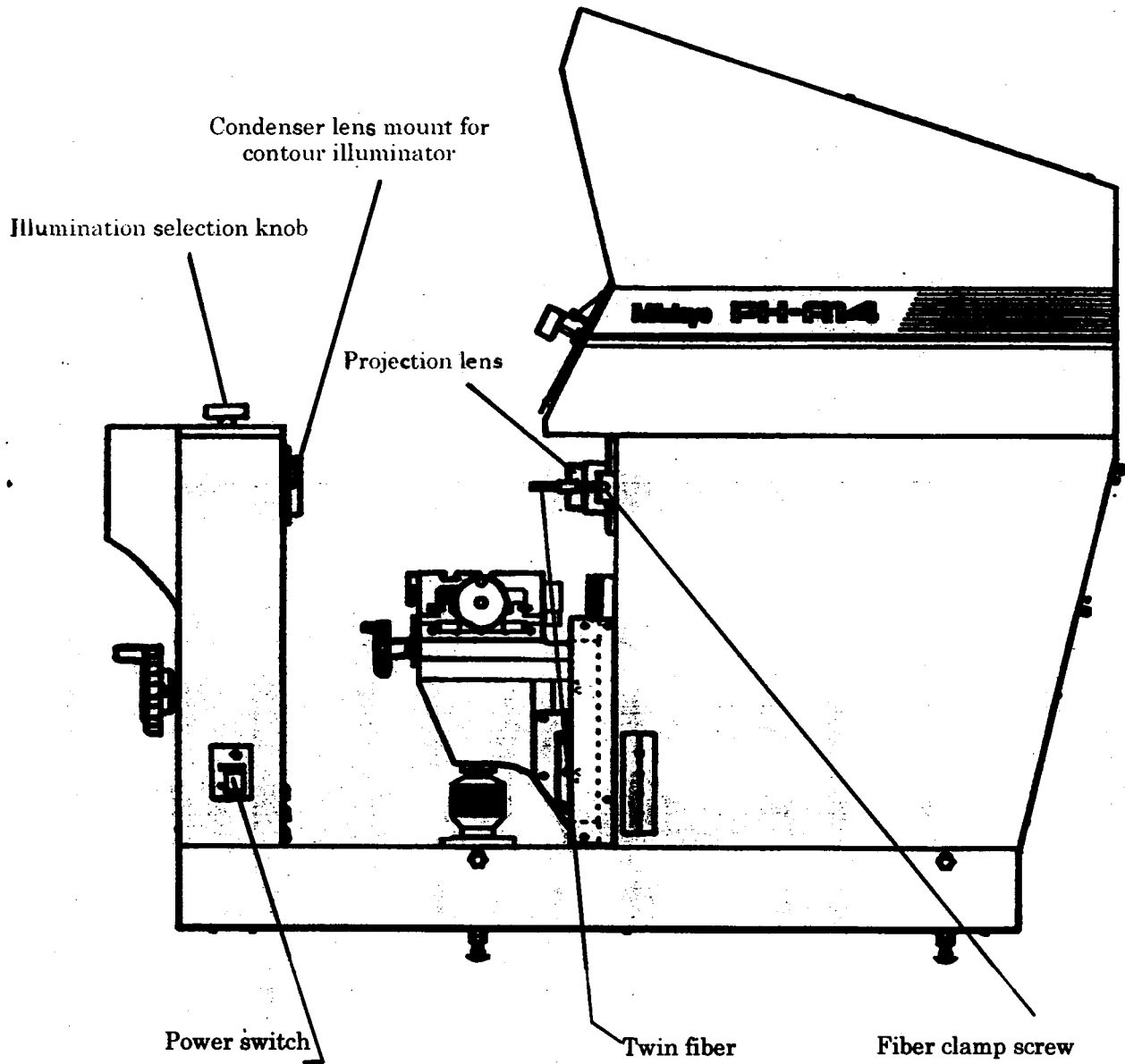

# 2

## Setup

This chapter describes the environment of the installation site, installation method including the part attachment, and magnification accuracy check.

### 2.1 Unpacking

The following describes how to unpack the PH-A14.

**Note** To unpack, a nail puller, scissors, cutter, and Allen key are required. Prepare these tools beforehand.

#### ●Procedure

① Remove the wrapping material using the scissors and cutter.

**Note** Confirm that the main unit does not have a significant fault or distortion.

② Separate the standard accessory box from the main package.

③ Take off the 4 pieces of screw bolt on the bottom of the table by wrench.

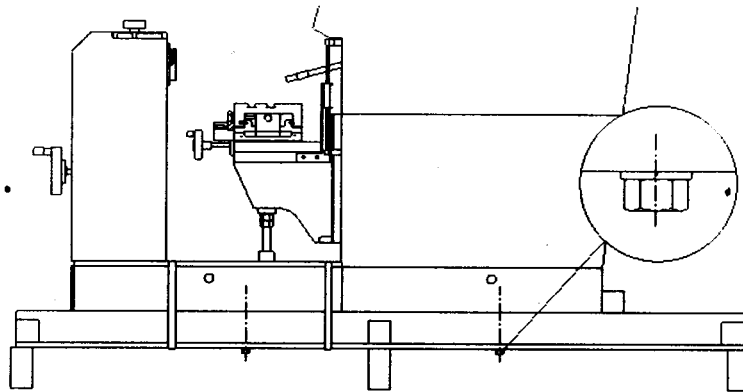

④ Remove the cushion protecting the protractor screen.

⑤ Open the standard accessory box and check the supplied accessories.

| Item                       | Part No.               | Quantity | Note  | Check |
|----------------------------|------------------------|----------|---|-------|
| Lens set 10X               | 172-172                | 1        |   |       |
| Halogen lamp 24V 150W      | 515530                 | 1        |   |       |
| Fuse                       | 6A (For 100 to 120V)   | 2        | A fuse is pre-installed in the fuse holder. |       |
|                            | 2.5A (For 220 to 240V) |          |   |       |
| Allen wrench (nominal 2.5) | 538615                 | 1        |   |       |
| Wrench                     | 12BAC245               | 1        |   |       |
| Operation Manual           | 99MBA051A              | 1        |   |       |
| Warranty Card              |                        | 1        |   |       |

## 2.2 Installation

Set-up the profile projector while observing the following points.

### 2.2.1 Environmental condition

- **Vibration**

The precision components of the projector will go out of adjustment if they are subjected to prolonged vibration, resulting in deterioration of measurement accuracy. If vibration is present at the setup site, take the necessary vibration-reduction measures, such as laying a vibration damping rubber pad under the projector.

- **Dust**

Airborne dust will adversely affect the optical parts such as lenses and mirrors and the precision mechanical parts of the microstage, causing wear and damage. The projector environment should therefore be as dust-free as possible.

- **Light**

Glare on the screen makes it difficult to view projection images. Direct sunlight can cause deformation of the projector due to thermal expansion, which will adversely affect measuring accuracy.

Therefore, the projector should be positioned so it does not face windows or room lights. It should be shaded with curtains, etc., if placed near a window.

- **Ambient temperature**

Temperature and humidity requirements for operating this projector are 0° to 40° and 20% to 80%, respectively. However, avoid installing this projector where steep temperature change or high humidity may be present. This will be detrimental to the measurement accuracy.

## 2.2.2 Transportation and installation

Be sure to use the supplied carrying handles when handling, shifting or installing the main unit and due to its heavy weight (140kg) four people will be required to carry it. The PH-A14 has been fully adjusted at the factory, therefore take special care when handling and setting up the projector so that no part of the projector is subjected to impact or vibration.

### (1) Installation of the main unit

This profile projector is heavy and should be placed on a sturdy steel desk, or equivalent. Refer to subsection "2.2.1".

If the main unit is shaky or not level, use the leveling bolts located on the bottom of the main unit to level it.

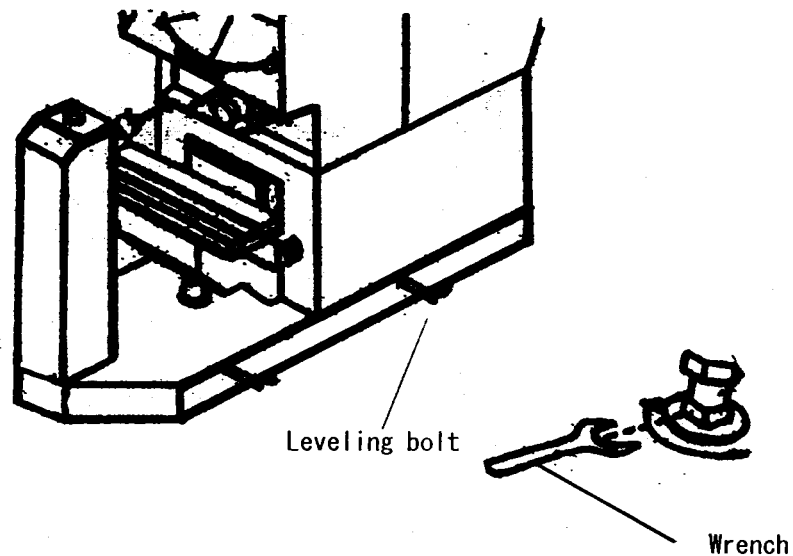

- ① Loosen the leveling bolts using the wrench.
- ② Adjust the main unit level with the leveling bolts.

### (2) Removing the carrying handles

After setup, remove the carrying handles.

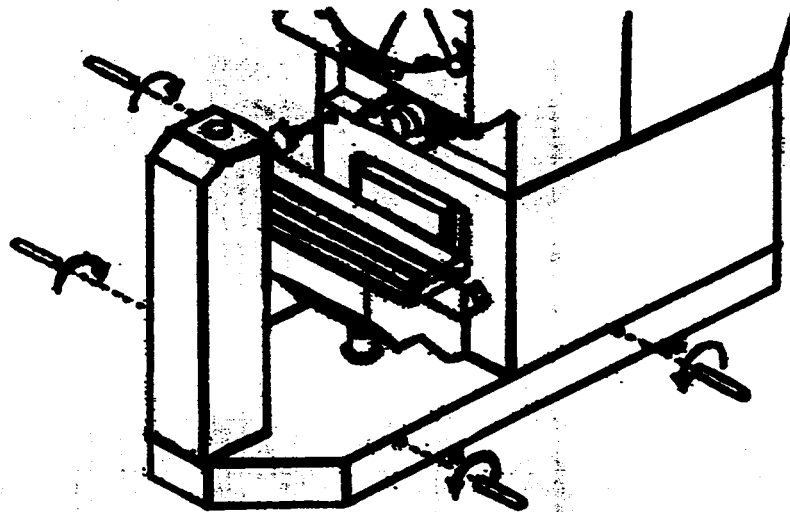

## 2.3 Attach the screen glass

- ① The glass receptacle of the upper end of a screen frame is removed with a slot screw-driver.
- ② Insert screen glass between two glass receptacles at the bottom.
- ③ Thrust the glass receptacle of the upper end into the screen glass, and thrust the glass receptacle into the position of insertion origin.

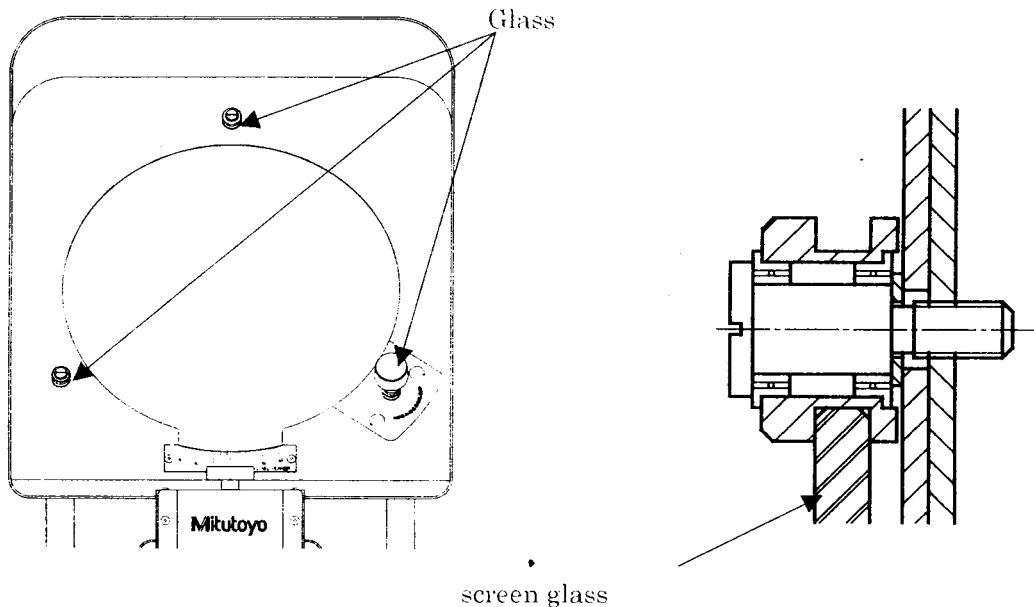

The state before

The glass

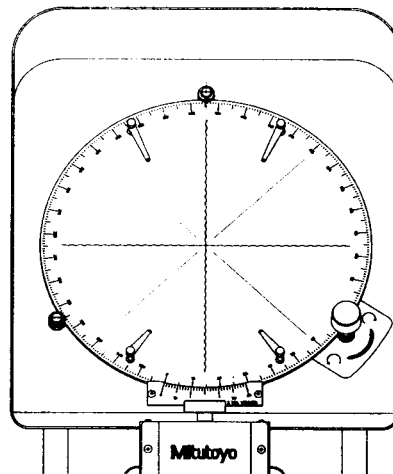

Attachment completion

## 2.4 Mounting the Lens

In mounting the projection lens, move the microstage down as required.

- ① Screw-in the projection lens into the lens mount as far as it can go.

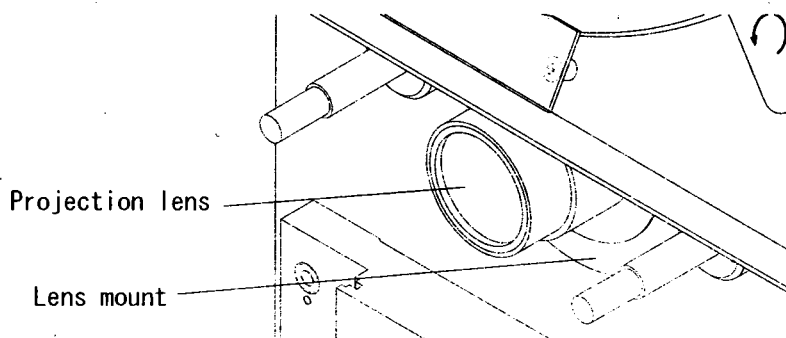

- ② When using a projection lens of 50X and 100X, select a condenser lens for contour illumination, which matches the magnification of the projection lens, and insert it firmly into the lens mount located at the front of the contour illuminator unit.

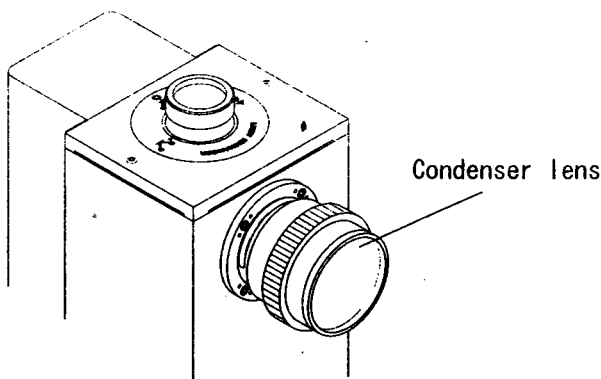

**Note** The condenser lens 10x and 20x are incorporated in the main unit.

## 2.5 Setting-up the Power Supply

The power supply specification is any voltage of 100V, 120V, 220V, or 240VAC $\pm$ 10% and either 50Hz or 60Hz. Provide the power supply according to the specification. A two-pole outlet with a ground terminal is required as the AC power outlet. Make allowance for the power output capacity in consideration of the total consumption of the system.



**TIP**

The system may require a power regulator if power fluctuation is not within  $\pm$ 10% of the specified voltage. An uninterruptible power system is required if there is any potential for power failure.

For more information, contact your dealer or the nearest Mitutoyo sales office.

**Note**

Only allow the power outlet at the installation site to be used for the machinery including the Power Focus Unit. Do not share the outlet with other electric equipment.

## 2.6 Checking the Magnification Accuracy

- ① Mount the projection lens and corresponding condenser lens for contour illumination.

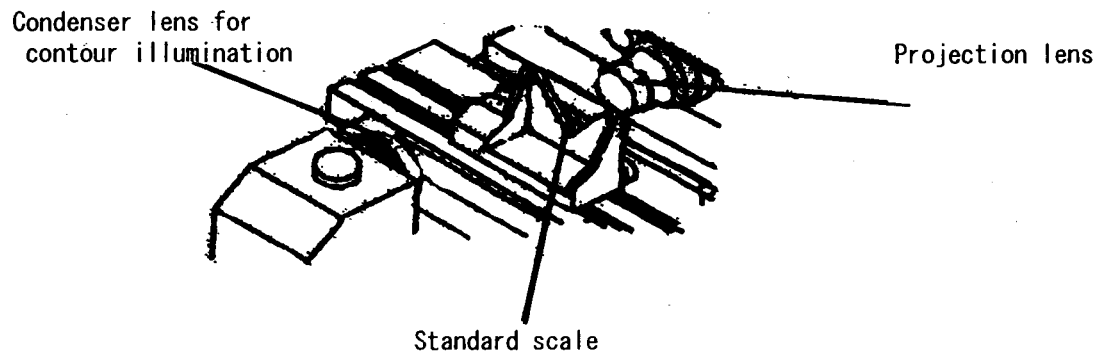

- ② Using a vertical workpiece holder (option), etc., place a standard scale (optional accessory, No. 172-116) on the microstage.
- ③ Project the image of this standard scale onto the screen and measure it using a reading scale (option) as follows.

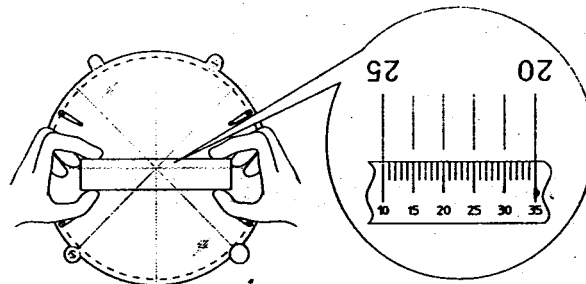

**Tip** Inverted image is projected on the screen.

- ④ Measure the projected image of the standard scale on the screen using a reading scale. Take measurements at three reference points (50mm, 120mm, 160mm) in four or more radial directions along the cross-hair lines on the screen.
- ⑤ Calculate the magnification error using the following formula:

$$\Delta M = \frac{L - lM}{lM} \times 100\%$$

$\Delta M$  : Magnification error  
 $L$  : Measured length of the standard scale.  
 $l$  : Length of the standard scale  
 $M$  : Magnification of the projection lens.

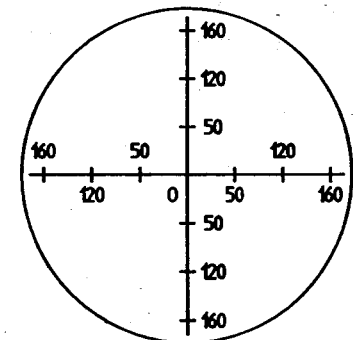

The magnification error is specified as  $\pm 0.05\%$  or less for contour illumination (within  $\phi 100\text{mm}$  of the central area on the screen). (If the magnification error for contour illumination falls within the tolerance, that for surface illumination will also fall within the specified tolerance of  $\pm 0.1\%$  (within  $\phi 100\text{mm}$  of central area on the screen)).

# 3

## Operation

This chapter describes the operations of the Profile Projector PH-A14 corresponding to various applications.

### 3.1 Positioning the Workpiece

Two parallel dovetail grooves are provided on the microstage surface-at intervals of 43mm. With these dovetail grooves, position a workpiece on the microstage using a special fixture that conforms to the workpiece feature or your jig.

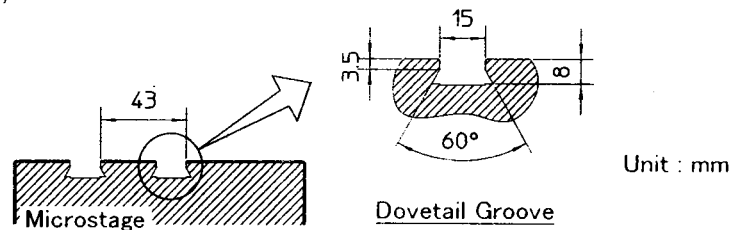

There are various types of dedicated fixtures provided for this profile projector, as follows.

| Model name                                | Appearance | Purpose   |
|---|------------|---|
| Center support<br>(No.172-142)            |            | Used to position a cylindrical workpiece which has two punched holes on both sides. |
| Riser<br>(No.172-143)                     |            | Used to offset the center support.  |
| V-block<br>(No.172-234)                   |            | Used to position a general cylindrical workpiece.                                   |
| Rotary vise<br>(No.172-144)               |            | Used to position a general cylindrical workpiece.                                   |
| Vertical workpiece holder<br>(No.172-132) |            | Used to hold a thin workpiece.  |

## 3.2 Projecting Methods

When turning on the power switch, the pilot lamp on the switch lights up.

The illumination lamp is lit simultaneously.

### 3.2.1 Projection by contour illumination

- The contour image of the workpiece is projected onto the screen.
- The contour illumination can be selected with the illumination selection knob.
- Be sure to use the condenser lens which corresponds to the magnification (50x, 100x) of the projection lens to be used.

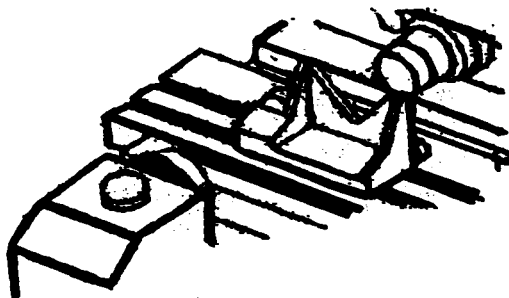

Position the workpiece so it intersects the optical axis of the projection lens (which is collinear with the axis of the contour illumination).

- If using a color filter

Insert an optional color filter (No. 172-286) into the slot behind the condenser lens mount.

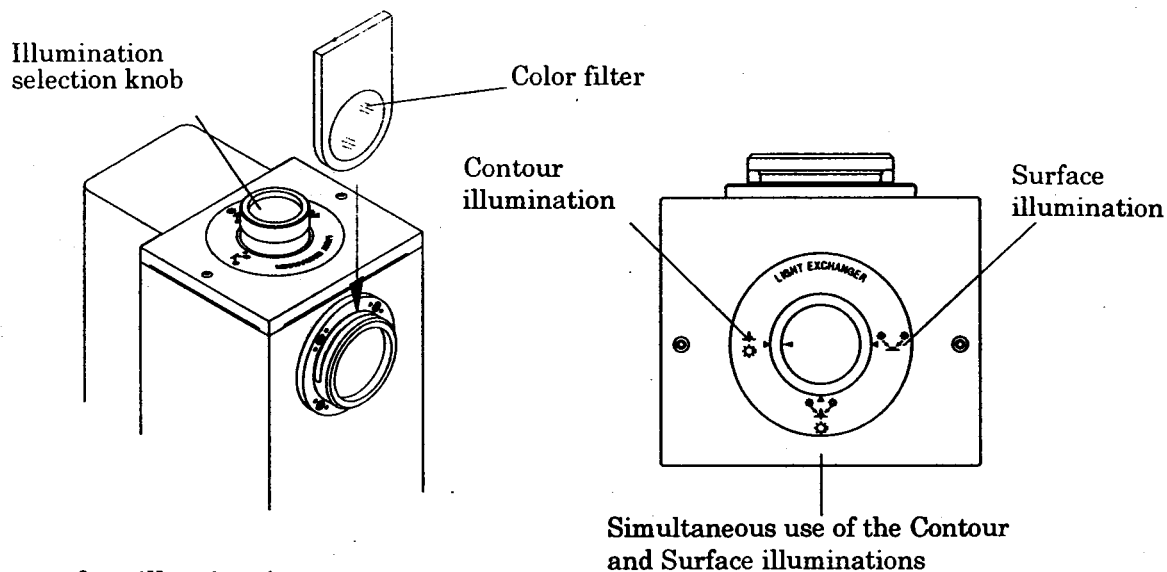

### 3.2.2 Projection by surface illumination

- The twin-fibers light beam is reflected on the workpiece surface, then its surface condition is projected on the screen.
- The twin-fibers surface illumination can be selected with the illumination selection knob.

### 3.2.3 Projection by contour and surface illumination

- The contour image and surface texture of the workpiece is projected onto the screen.
- The illumination can be switched with the illumination selection knob.

### 3.3 General Measurement and Inspection

This profile projector has a wide range of measuring applications. Select a measuring method that suits the shape, size, quantity of the workpiece, and the measuring purpose and requirements. How to measure/inspect a workpiece is explained below

#### 3.3.1 Dimensional measurement using a scale

After completing the procedure as shown in 3.2, place the scale on the screen and measure the enlarged image. Divide the measurements by the magnification of the projection lens to determine the actual dimensions.

(Example)

Measured value on the screen : 150mm  
 Projection lens magnification : 10X  
 Actual dimension of the workpiece : 15mm

- The optional reading scale is ideal for this type of measurement because the graduated surface of the scale fits on the screen glass, providing parallax-free measurement.

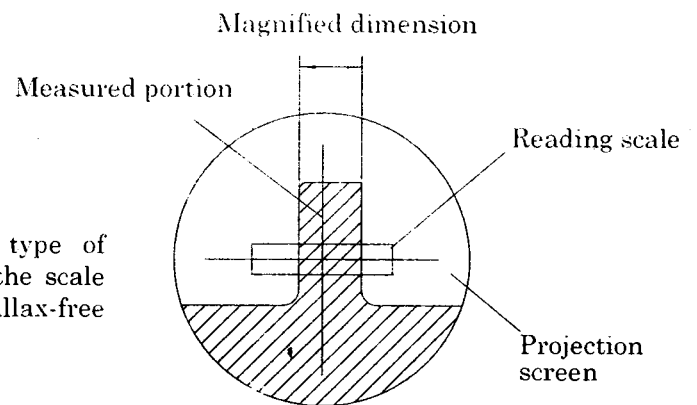

#### 3.3.2 Comparison with an overlay chart

After completing the procedure as shown in 3.2, perform measurement and inspection by comparing the workpiece image with the standard overlay chart which is custom-made for the selected magnification. Use this method for measurement of shapes, multiple point and dimensions.

This method of measurement is suitable for checking a complex part feature which cannot be inspected in a simple one-dimensional measurement.

Adding tolerance lines to the standard overlay chart will improve inspection efficiency, since workpieces can be inspected with reference to these lines.

Standard charts can be made from the workpiece blueprint, or the master workpiece image projected on the screen. Use transparent or semi-transparent tracing sheets (or film) to make them. For close inspection or for long-term storage, plastic tracing sheets are recommended because of their greater dimensional stability.

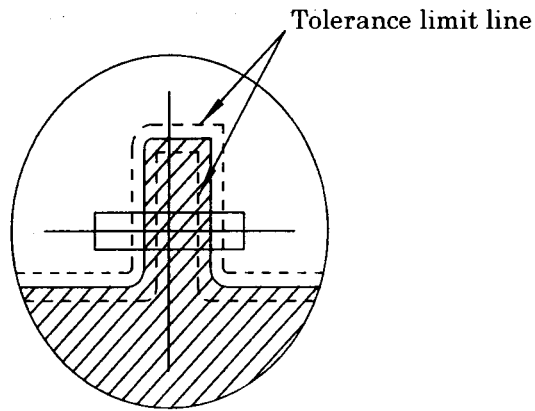

### 3.3.3 Measurement using an external counter/2D data processing unit

This projector can easily perform high-accuracy measurement with the linear scales built in the microstage/stage base, which are connected to an external counter (KS counter or Opt-eye A2 counter) or 2D data processing unit (QM-Data200).

#### (1) Connection to an external counter/2D data processing unit

The linear scales incorporated in this projector are described below. Connect the connectors from two axes of linear scales to the following specified portions on the external counter or 2D data processing unit.

\* X axis: Linear scale AT115-200 with a minimum reading of  $1\mu\text{m}$

\* Y axis: Linear scale AT115-100 with a minimum reading of  $1\mu\text{m}$

#### (2) Operating procedure with the external counter/2D data processing unit

For detailed information, refer to the user's manuals of KS Counter, Opt-eye A2 Counter, and 2D Data Processing Unit.

# 4

## Maintenance

This section describes the daily maintenance PH-A14 Profile Projector, including cleaning, and replacing consumable parts.

### 4.1 Maintenance of Optical Components

The maintenance method for the optical components of the profile projector is explained below.

#### 4.1.1 Projection lens and condenser lens

Compared with ordinary hard glass, the optical glass of the projection lens or condenser lens used for this projector is soft and subject to scratches. In order to remove dust, do not use a cloth to wipe the lens. Use a blower brush instead.

To remove oil or fingerprints, dampen a piece of clean gauze with high-grade alcohol and wipe gently using a circular motion.

For lens storage, replace the lens cap and store it in its case.

Replace the lens cap when the projector is not in use. The lens does not have to be removed from the projector.

#### 4.1.2 Mirror (surface reflection mirror)

The mirrors inside the machine are called surface reflection mirrors and the reflection surfaces are easily scratched. Exercise care so as not to allow dust or oil mist inside the machine.

Should the mirror have to be cleaned, dust must be blown away with a blower, rather than be wiped off.

**Important** Do not wipe off the stains on the mirror surface with gauze or tissue paper.

#### 4.1.3 Screen glass

Use a soft cloth with high-grade alcohol and wipe the glass when removing oil and finger prints.

**Important** In cleaning, be careful not to allow alcohol drops inside the machine.

### 4.2 Maintenance of Mechanical Components

The maintenance method for the mechanical components of the profile projector is explained below.

#### 4.2.1 Projector main unit

Periodically apply a thin coat of grease on the feed screws and gears of the microstage vertical travel using a brush.

#### 4.2.2 Microstage

Apply a small amount of spindle oil to the V-groove guide rail.

## 4.3 Replacing Consumable Parts

The replacement method for the consumable parts of the profile projector is explained in the following.

### 4.3.1 Fuse

- ① Turn the power switch to off.
- ② Pull the power plug from the power outlet.
- ③ Insert a screwdriver in the slot on the upper side of the fuse holder case located on the rear side of the main unit. Then press it down and the fuse holder will come out of the case.
- ④ Replace the cut fuse. then insert the fuse holder in the case.

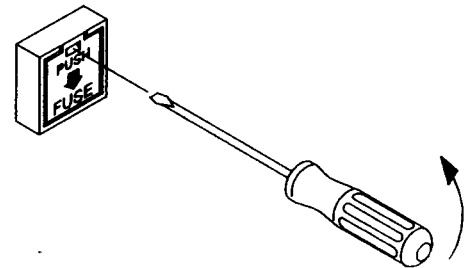

### 4.3.2 Bulbs for contour and surface illuminators

- ① Turn the power switch off.
- ② Remove the illumination selection panel with an Allen wrench (nominal 3). At this time, pull the panel straight up, confirming the incorporated cylinder-shaped selection unit in the panel does not hit the lamp or lamp housing.
- ③ Remove the bulb by pulling it straight up after the lamp and lamp housing have cooled down.
- ④ Insert a new lamp straight into the socket. When inserting a new one, do not hold it by your bare hands. Use a clean piece of paper, etc., as shown on the right, and insert it as far as it can go.
- ⑤ Reattach the illumination selection panel. At this time, slowly lower it so that the incorporated cylinder-shaped selection unit in the panel does not hit the lamp or lamp housing.

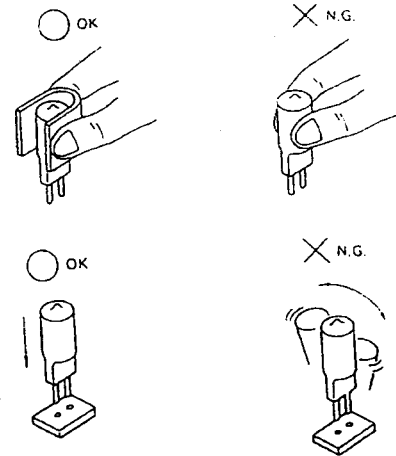

Caution

1. To prevent personal injury, do not touch the hot bulb during use or immediately after turning it off.
2. To prevent the bulb from being soiled by oil or finger-prints, do not touch the bulb with your bare hands.
3. Do not apply force to the bulb pin in the horizontal direction, or the bulb could be damaged.

### 4.3.3 Periodic inspection

In order to obtain a long service life from the PH-3500 Profile Projector, periodically perform inspection, cleaning, and necessary lubrication.

### 4.3.4 List of parts for maintenance

| Item         | Part No. | Note   |
|--------------|----------|--|
| Halogen lamp | 515530   | 24V 150W (For Contour and Surface illuminations) |
| Fuse         | 6 A      | 358191   |
|              | 2.5 A    | 384208   |
|              |          | For 100~120V                                     |
|              |          | For 220~240V                                     |

# 5

## Troubleshooting

When the Profile Projector PH-A14 malfunctions, diagnose the problem and remedy the situation with the aid of the following tables. If the problem cannot be resolved with the procedures presented here, contact your dealer or nearest Mitutoyo Service Center.

### 5.1 Problems on the Power Supply

| Symptom  | Possible cause/Check point   | Inspection/Remedy  |
|--|--|--|
| The power switch is On, but the pilot lamp is not lit            | ① Is the power cord properly connected?  | Connect the cord properly.   |
|  | ② Is the fuse OK?  | Replace the fuse. (Refer to 4.3.1)   |
|  | ③ Does the power switch operate normally?  | Contact Mitutoyo if the system does not work correctly even after the checks and remedies described in the left hand column.   |
|  | ④ Is the input voltage to the power switch or fan motor okay?                              |  |
| The illuminator lamp does not light when the power switch is ON. | ① Does the pilot lamp in the power switch light?   | Contact Mitutoyo if normal operation is not achieved after the checks and remedies were carried out according to the instructions on the previous symptom "The power switch is On, but the pilot lamp is not lit". |
|  | ② Is the fan motor working properly?   |  |
|  | ③ Is the lamp filament OK?   | Replace the lamp. (Refer to 4.3.2)   |
|  | ④ Turn the power switch to OFF and wait for more than 5 seconds. Then turn it again to ON. | If the lamp does not light after two or three tries, contact Mitutoyo.   |

## 5.2 Problems on the Operation

| Symptom  | Possible cause/Check point   | Inspection/Remedy   |
|--|--|---|
| Focusing is not performed smoothly.                            | Is the operation of the focusing wheel smooth?   | If there is play, excessive tight or uneven movement, or abnormal noise in the wheel, contact Mitutoyo. Do not disassemble the unit or do not rotate the focusing wheel forcibly. |
| Error is observed in glass scale or overlay chart measurement. | This may be a magnification error. Check the magnification accuracy by referring to 2.5. | Contact Mitutoyo if normal operation is not achieved after the checks and remedies were performed according to the instructions in the left hand column.                          |
| Abnormal protractor screen operation.                          | Does the screen rotation knob rotate smoothly?   | If the screen rotation, fine adjustment, or clamp does not work normally, contact Mitutoyo. Do not rotate the knob forcibly.  |
| Partially obscured image                                       | ① Is the projection lens properly mounted?   | Mount the projection lens correctly.<br>(Refer to 2.3)  |
|  | ② Is focusing correct?   | Perform focusing correctly.   |
|  | ③ Is there any stain or damage on the projection lens?                                   | Clean the projection lens.<br>(Refer to 4.1.1)  |
|  | ④ Is there any stain or damage on the surface reflecting mirror?                         | Clean the reflecting mirror.<br>(Refer to 4.1.2)  |
|  | ⑤ Is there any stain on the projection screen?   | Clean the projection screen.<br>(Refer to 4.1.3)  |

\* Contact Mitutoyo if normal operation is not achieved even after the checks and remedies as described above are carried out.

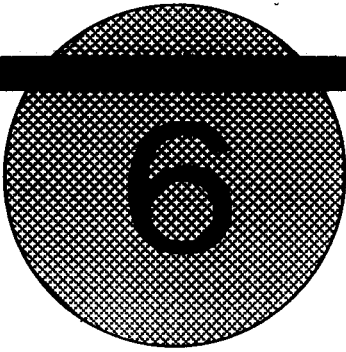

# Specifications

## 6.1 Main Unit

|  |  |  |
|--|--|--|
| Model                                  |  | PH-A14   |
| Projected image                        |  | Inverted image   |
| Protractor screen                      | Effective measurement diameter                   | 356mm (14")  |
|  | Angle reading                                    | Vernier reading, Resolution: 2'  |
| Projection lens                        |  | 10x(standard accessory), 20x, 50x, 100x (option)   |
| Magnification accuracy                 | Contour illumination                             | Central area on the screen (area enclosed by an imaginary central circle $\phi 100$ (4")) : $\pm 0.05\%$ or less<br>The rest of the area on the screen (area outside an imaginary central circle $\phi 100$ or less) : $\pm 0.1\%$ or less |
|  | Surface illumination                             | Central area on the screen (area enclosed by an imaginary central circle $\phi 100$ or less)   |
| Micro-stage (X-axis)                   | Measuring range                                  | 203mm (8")   |
|  | Reading unit                                     | Linear Scale   |
|  | Minimum reading                                  | ※ 1 0.001mm (.00005")  |
|  | Displacement accuracy : When no load is applied. | (6+L/15) $\mu$ m<br>L = Measuring length(mm)   |
|  | Table size                                       | 407mm (16") $\times$ 153mm (6")  |
| Vertical travel unit (Y-axis)          | Measuring range                                  | 102mm (4")   |
|  | Reading unit                                     | Linear Scale   |
|  | Minimum reading                                  | ※ 1 0.001mm (.00005")  |
|  | Displacement accuracy : When no load is applied. | (6+3L/15) $\mu$ m<br>L = Measuring length (mm)   |
| Possible traveling amount for focusing |  | 50.8mm (2")  |
| Maximum loading capacity               |  | 45kg (100lb)   |
| Contour illumination unit              |  | 24V, 150W halogen lamp<br>Telecentric illumination • Built-in heat absorbing filter and cooling fan • Color filter (options) is available  |
| Surface illumination unit              |  | 24V, 150W halogen lamp (Common to the contour illumination) Twin fiber-optic illuminator   |
| Power source                           |  | AC100V/120V/130V/230V/240V 50/60Hz   |
| Power cable length                     |  | 2.5m(98")  |
| Main unit dimension                    |  | W $\times$ D $\times$ H: 612 $\times$ 1240 $\times$ 1158mm<br>(24.1" $\times$ 48.8" $\times$ 45.6")  |
| Main unit mass                         |  | Approx. 140kg (308lb)  |

※ 1 Resolution shows the value for the case KS counter or QM-Data200 is used.

## 6.2 Projection Specifications

The following projection lenses are available for this profile projector, either as a standard or as an option.

| Magnification         |   | 10 ×        | 20 × | 50 × | 100 × |
|-----------------------|---|-------------|------|------|-------|
| Mounting method       |   | Screw mount |      |      |       |
| Projection capability | Field of view   | 35.6        | 17.8 | 7.12 | 3.56  |
|                       | working distance  | A           | 93   | 40   | 14.6  |
|                       | Maximum workpiece height  | L           | 235  | 235  | 109   |
|                       | Maximum projecting diameter                                       | D           | 102  | 102  | 31.3  |
|                       | Maximum distance between the optical axis and microstage top face | H           | 102  |      |       |

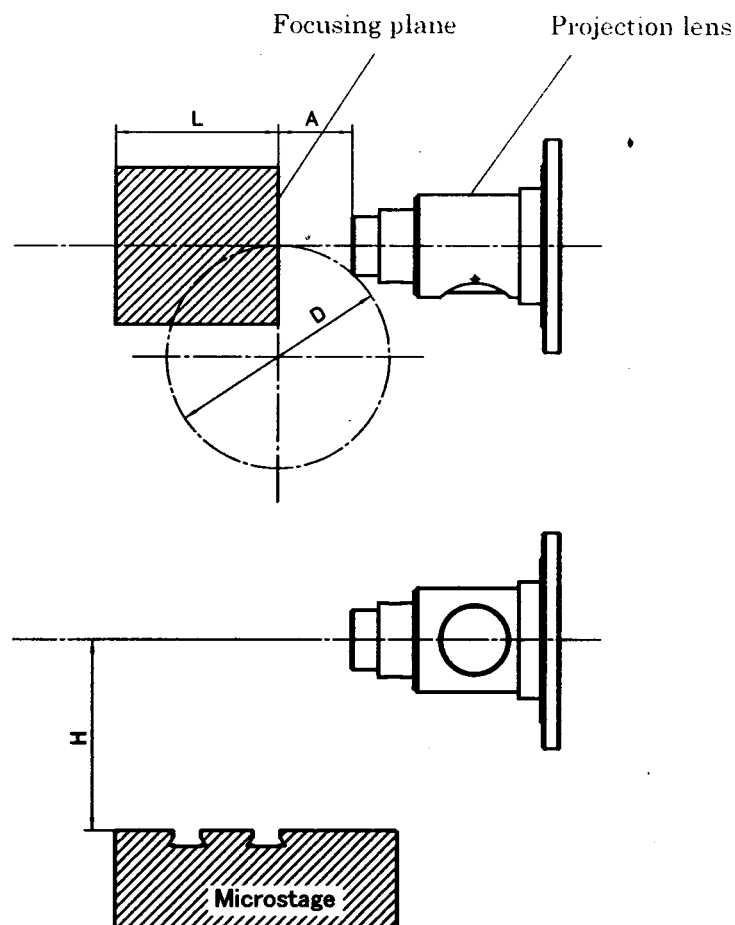

## 6.3 Accessories

### 6.3.1 Standard accessories

Refer to "2.1".

### 6.3.2 Optional accessories

| Order No.    | Name   |
|--------------|--|
| 172-012      | Projection lens 20 X   |
| 172-013      | Projection lens 50 X   |
| 172-014      | Projection lens 100 X  |
| 172-117      | Standard scale 2"  |
| 172-119      | Reading scale 8"   |
| 172-162      | Reading scale 12"  |
| 172-116      | Standard scale 50mm  |
| 172-118      | Reading scale 200mm  |
| 172-161      | Reading scale 300mm  |
| 172-286      | Color filter   |
| 12AAB817     | Condenser lens for the fiber-optic illumination (2 pcs/ set)         |
| 172-142      | Center support   |
| 172-143      | Riser  |
| 172-144      | Rotary vise  |
| 172-132      | Vertical workpiece holder  |
| 172-234      | V-block  |
| 172-001      | Tip-saw support stand ※1   |
| 172-002      | Cutter support stand ※1  |
| 174-103-1 ※2 | KS counter (Recommended counter)                                     |
| 332-115-1 ※2 | Optoeye A2 counter   |
| 270032       | Detector attachment plate (For Optoeye image edge sensor attachment) |
| 264-141 ※2   | 2D data processing unit QM-DATA-200 (Arm type)                       |
| 264-140 ※2   | 2D data processing unit QM-DATA-200 (Stand type)                     |

※ 1 : Fixture for chip saws or cutters is corresponding to the center hole of  $\phi 25.4\text{mm}$  of the cutter tools.

※ 2 : Order No. differs depending on the power supply voltage used.

| Order No. | Name   |
|-----------|--|
| 932105    | Overlay chart : 12 sheet set   |
| 512066    | Overlay chart :<br>Top portion: 1 -grad. radical index<br>Bottom portion: 1mm-radius increment concentric semicircles                                    |
| 512067    | Overlay chart :<br>5mm-radius increment concentric circles,<br>1mm-reading cross hair  |
| 512068    | Overlay chart : 1mm-radius increment<br>concentric circle with cross hair  |
| 512069    | Overlay chart :<br>50mm pitch horizontal parallel lines,<br>20mm pitch vertical parallel lines   |
| 512070    | Overlay chart : 10 x 10mm sections   |
| 512071    | Overlay chart : 5mm-reading cross hair   |
| 512072    | Overlay chart : 1 x 1mm sections 1mm   |
| 512073    | Overlay chart : 1 -grad. radical index   |
| 512074    | Overlay chart : 1mm pitch parallel lines   |
| 512075    | Overlay chart :<br>1mm-radius increment concentric circles,<br>1 -grad. radical index  |
| 512076    | Overlay chart :<br>Metric thread (20x) : P=0.2~2mm<br>Unified thread (20x) : 28~12 threads<br>Whitworth screw thread (20x) : 20~10 threads               |
| 512077    | Overlay chart :<br>Metric thread (100x) : P=0.075~0.225mm<br>Involute gear tooth (20x)<br>Pressure angle 20° , m=0.2~1<br>Pressure angle 14.5° , m=0.2~1 |

## 6.4 External Dimensions

