

G. Refer to Fig. 7 for detailed connection to terminal studs. All hardware, including terminal lugs, is supplied with unit.

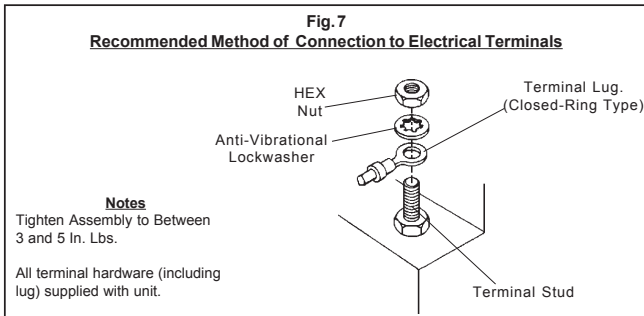

- H. Fusing of the SAFE-PAK to be in accordance with Fig. 1. Fuse F1 to be 1 amp "slo-blo". 120 VAC for 120 V line voltage.
- I. Protective cover (supplied) must be in place over sensor-connected terminals of the PAK after wiring has been completed. (See Fig. 8)

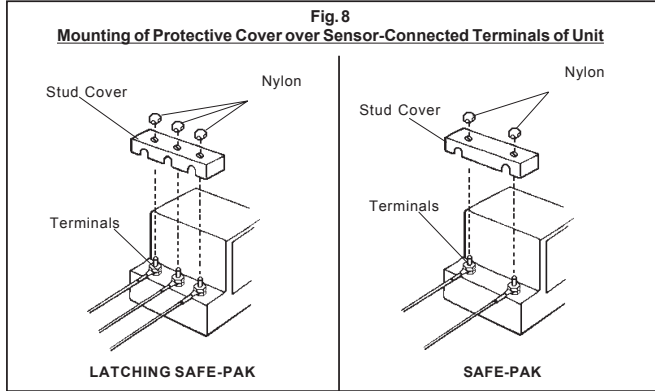

P/N 64558
Rev. J

Low Sensitivity SAFE-PAK[®]
and Latching SAFE-PAK[®]
Instruction Bulletin No. 64558

For use as an "intrinsically safe switch circuit", in hazardous locations Class I, Division 1, Groups A, B, C, and D and Class II, Division 2, Groups E, F, and G. Gems' SAFE-PAK is suitable for installation in Class I, Division 2 or non-hazardous locations. **IMPORTANT! Read carefully and completely before installing or connecting SAFE-PAK or Latching SAFE-PAK**

*** **Warning:** To prevent ignition of flammable or combustible atmospheres, disconnect power before servicing.

1. **Associated Equipment - Caution:** The SAFE-PAK must be mounted outside the hazardous area. Only the switch or sensor terminals provide an intrinsically safe switch circuit (see Fig. 1, Fig. 2 or Fig. 3). [Exia] means associated equipment: "Appareillage connexe", located in safe area.

Fig. 1.
Connection Diagram: Gems SAFE-PAK Models

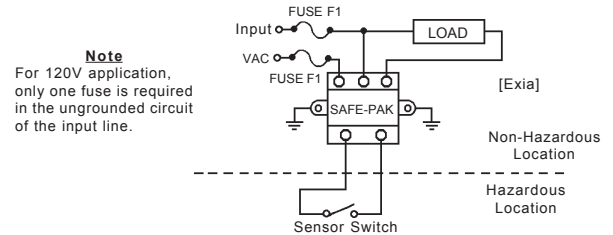
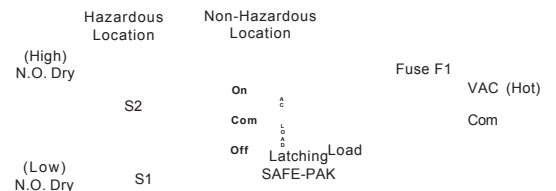
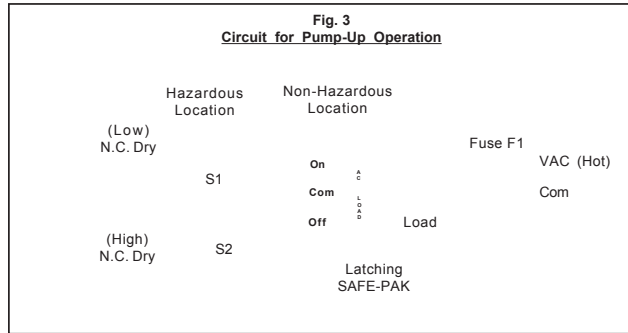

Fig. 2.
Circuit for Pump-Down Operation





2. Mounting and Enclosure Considerations:

- A. Field wiring of intrinsically safe circuits is to be segregated from non-intrinsically safe wiring by use of suitable barriers, separate wireways or trays (See Fig. 4). Wire insulation to be .010" minimum.
- B. Intrinsically safe and non-intrinsically safe connection points should be located sufficiently apart to prevent any possibility of bypassing or miswiring during installation or servicing of equipment.
- C. The enclosure shall contain a cautionary statement as follows: "CAUTION: ANY SUBSTITUTION OF COMPONENTS MAY IMPAIR INTRINSIC SAFETY".
- D. The PAK mounting bracket must be grounded to insure intrinsic safety. Resistance between bracket and ground electrode should be below one ohm. (See Fig. 5 and Fig. 6 for recommended selection of grounding hardware and refer to Article 250 of the National Electrical Code for methods and practices.)

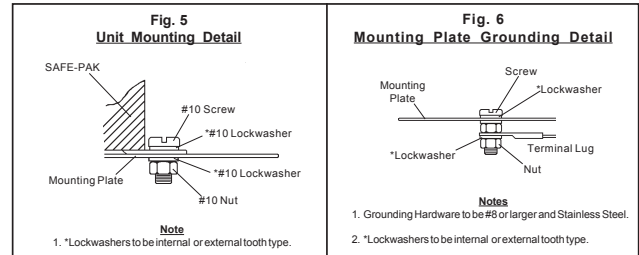
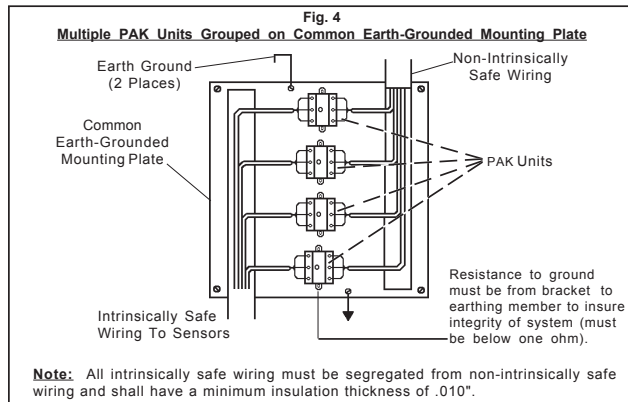

3. Installation of Sensor Switch and Running of Field Wiring:

- A. The nature of the sensor switch must be that it is a non-voltage-producing, essentially resistive device, containing no energy-storing components.
- B. The conductors of the intrinsically safe circuit should be sealed in a rigid metal conduit at the point where the wiring enters the hazardous area. The wiring and contacting device should be such that conductive dusts in the area will not close the circuit in place of the contacts.
- C. Hazardous area field wiring will store energy due to distributed capacitance and inductance in proportion to its length. It is therefore recommended that the characteristics (available from the manufacturer) of the cable be known and judged against the length of run and atmosphere of exposure. The following conservative chart is presented as a guideline in determining the limits of reactance for signal loops in the hazardous area wiring for the SAFE-PAK series.

Example: Typical values of capacitance for a twisted pair of copper wires is between 20 and 60 pf per foot. Inductance of a typical twisted pair is between 0.10 and 0.20 uH/ft., thus making a cable run in this example essentially determined by the inductance. Because of the low sensitivity of the device, maximum lead length is limited to a total switch lead resistance of 200 ohms.

GROUP	CAPACITANCE	INDUCTANCE
A & B	1 uf	.50 mh
C	1 uf	.50 mh
D	1 uf	.50 mh

- D. Whenever possible, the actual measured parameters should be used in making the determination of allowable length.
- E. Shielded cable is not required; but if used in the application, the shield must be returned to ground - the same as the PAK mounting bracket.
- F. Non-intrinsically safe wiring cannot be run in conduit or open raceways together with intrinsically safe wiring.