

# E<sup>3</sup>Point Gas Monitor

## Quick Start Guide

This guide applies to the E<sup>3</sup>Point<sup>®</sup> standalone, network, and remote monitors. The monitors can be used in indoor environments such as parking garages, commercial kitchens, and mechanical rooms among other. An optional water shield (ECLAB) is also available.

### ⚠ WARNING

- Power to the E<sup>3</sup>Point monitor must be off during installation and when installing the sensor cartridge.
- The installer must be grounded for ESD protection while handling the PC board (PCBA) and during installation of the monitor.
- Follow all local codes when installing the monitor.
- Operate, service, and use the monitor only as specified in this quick start guide and the user manual. Failure to do so may impair the protection the monitor is designed to provide and may also void the warranty. The manual is available on the Honeywell Analytics website: [www.honeywellanalytics.com](http://www.honeywellanalytics.com)  
[www.honeywell.com](http://www.honeywell.com)
- Calibration, set-up, and test modes are intended for use by trained personnel and service engineers only. Access to these modes can be passcode protected.
- Follow local and site procedures when working with this monitor. If applicable, verify that the associated control panel is inhibited in order to prevent false alarms during installation. The procedures in this quick start guide and the product's manual must be followed carefully and performed only by trained personnel and service engineers.
- Use only accessories and parts meeting or exceeding Honeywell Analytics' specifications.
- Some monitors require warm-up time. See the user manual for specific information. Do not paint over the monitor screen
- Ensure that the monitor screen is free of dirt and debris.
- Ensure that the monitor screen is not covered.
- Do not expose the monitor to electrical shock and/or continuous mechanical shock.



Scan QR code for manual

**The warranty will be voided if the customer or any unauthorized service personnel attempt to repair the monitor**

### ⚠ CAUTION

- The E<sup>3</sup>Point monitor must be installed only by trained personnel and service engineers in accordance with local codes.
- The safety of any system incorporating the E<sup>3</sup>Point monitor is the responsibility of the assembler of the system.
- Protect the monitor from water, wash-down, and excessive humidity.
- To prevent electrical interference, keep the monitor and wire runs away from mercury vapor lights, variable speed drives, and radio repeaters.
- Protect the monitor from physical damage (fork lifts, etc.).
- Do not mount the monitor over a door in a refrigerated area.
- For critical locations, more than one monitor should be installed in each room.
- Use caution when opening E3Point or E3Point duct mount enclosures to avoid damage.

Specifications	
Uses	<b>Standalone</b> duct or wall mounted gas monitor with optional additional <b>Remote</b> monitor.
	<b>Network</b> duct or wall mounted gas monitor. Communicates with 301C (or AA96D) at 9600 Baud.
Size	<b>Standalone/Network monitor</b> (H x W x D): 20.56 x 14.90 x 6.72 cm (8.09 x 5.87 x 2.65")
	<b>Remote monitor</b> (H x W x D): 3.5 x 4.5 x 6.5 cm (1.36 x 1.75 x 2.56") 38 g (1.34 oz)
Electrical Ratings	<b>Standalone/Network monitor</b> 24 Vac 350mA 60 Hz 24 Vdc 350 mA OR <b>E3SAH only</b> - 120 Vac 75 mA
	<b>Remote monitor</b> – Class 2 or limited power source (lps) only Electro-Chem Sensor: 10 - 24 Vdc 50 mA OR Catalytic Bead Sensor: 10 - 16 Vdc 100 mA
Sensor Types and Operating Parameters	<b>Electro-Chemical</b> – (CO, NO <sub>2</sub> , H <sub>2</sub> S, O <sub>2</sub> ); <b>Catalytic Bead</b> – (CH <sub>4</sub> , H <sub>2</sub> , C <sub>3</sub> H <sub>8</sub> ) Indoor use, Maximum altitude 2000 M, 15 – 80% RH Response Time: T90 < 50 seconds; with ECLAB (water shield): T90 < 240 seconds All sensors except CO: -40 to 50°C (-40 to 122°F) CO: -20 to 50°C (-4 to 122°F) CO for UL 2075: 15 - 35°C (59 - 95°F)
Outputs	<b>Standalone monitor</b> 2 DPDT relays, 5 A @ 250 Vac and 30 Vdc 4-20 mA
	<b>Network monitor</b> 1 DPDT relay, 5 A @ 250 Vac and 30 Vdc MODbus and BACnet MS/TP master
	<b>Remote monitor</b> – Provides MODbus signal back to Standalone monitor for processing. 4-20 mA output not available for Remote monitor. OUT1 and OUT2 are not used.
Display	<b>Standalone/Network monitor</b> – 8 character, 2 line backlit LCD
Visual Indicators	<b>Standalone monitor</b> Green LED: Power Amber LED 1: Alarm/Fault Amber LED 2: Alarm/Fault
	<b>Network monitor</b> Green LED: Power Amber LED 1: Alarm/Fault Amber LED 2: Transmission
	<b>Remote monitor</b> – Amber LED: Transmission
Audible Alarm	<b>Standalone/Network monitor</b> - > 85 dBA at 3 m (10 ft)
Enclosure	Polycarbonate
Certification	Safety Requirements For Electrical Equipment For Measurement, Control, And Laboratory Use - Part 1: General Requirements [UL 61010-1:2012 Ed.3+R:29Apr2016]
	Safety Requirements For Electrical Equipment For Measurement, Control, And Laboratory Use – Part 1: General Requirements (R2017) [CSA C22.2#61010-1-12:2012 Ed.3+U1;U2]

## Installation

The main installation considerations are height and detection objectives. See the user manual for guidance.

- The monitor must be mounted on a vertical surface, oriented right side up. When correctly oriented, its control panel will look like this:



Do not mount the monitor flat on a ceiling or on a vibrating surface. Install the monitor's sensor cartridge only after the enclosure installation is complete.

Detected Gas		Relative Density (air=1)	Installation Height
CO	Carbon monoxide	0.968	3-5 ft (1-1.5 m) from floor
H <sub>2</sub> S	Hydrogen sulfide	1.19	3-5 ft (1-1.5 m) from floor
NO <sub>2</sub> *	Nitrogen dioxide	1.58 (cold)	1-3 ft (0 cm-1 m) from ceiling
O <sub>2</sub>	Oxygen	1.43	3-5 ft (1-1.5 m) from floor
Combustibles		Most combustibles are heavier than air. Exceptions are methane, hydrogen, ethylene, and acetylene. Install monitors for heavier-than-air gases about 1 ft (30 cm) from the floor. For combustibles that are lighter than air, install monitors 1 ft (30 cm) from the ceiling, close to potential leak sources.	

\* May differ in certain applications. Hot NO<sub>2</sub> from exhaust systems is lighter than ambient air.

## Duct Mounting for Standalone/Network monitor

The monitor must be duct mounted using the custom housing provided with the duct mount version. All of the components in the housing are factory assembled. Gas detection in ducts works best with airflows between 500–4000 fpm.

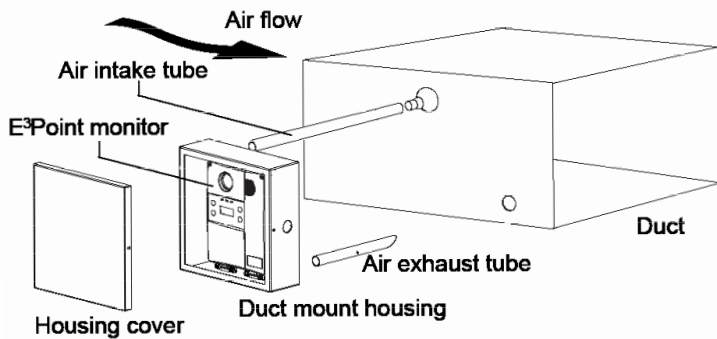

1. Verify that power to the monitor is off.
2. Measure and mark the holes for the intake and exhaust tubes.
3. Drill the holes in the duct for the sampling tubes (1 1/2 in., 38 mm) for the air intake tube, 1/2 in. (13 mm) for the air exhaust tube).
4. Affix intake and exhaust tubes to the duct mount housing.
5. Insert the tubes into the holes in the duct.
6. Orient the air holes on the air intake tube facing the airflow.
7. Attach the housing to the duct with four 8 x 3/4" galvanized or zinc-plated sheet metal screws (not provided).
8. While properly grounded for ESD protection, remove the PCBA from the monitor. It is attached by a single center screw. Carefully place the PCBA in the enclosed antistatic envelope.
9. Remove one of the knockouts (depending on where cables will enter the housing) and affix appropriate conduit.
10. Run wiring through the conduit and the housing to the monitor (See wiring section).
11. Re-install the PCBA.
12. Install the sensor cartridge.
13. Connect the wires (see the appropriate section below).
14. Screw the cover onto the monitor and replace the housing cover.
15. Restore power to the monitor.

## Wall Mounting for Standalone/Network monitor

1. Verify that power to the monitor is off.
2. While properly grounded for ESD protection, remove the PCBA from the monitor. It is attached by a single center screw. Carefully place the PCBA in the enclosed antistatic envelope.
3. Drill two holes through the case and into the mounting surface; horizontally if mounting on a vertical surface or vertically if mounting to a standard electrical box as indicated below.

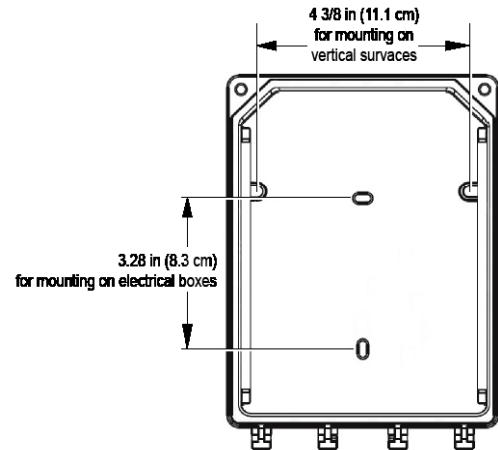

4. To mount the monitor, refer to the table for appropriate hardware and drill size. Use the enclosed mounting template to drill into the vertical surface if required.

Mounting Surface	Example Part	Description	Drill Bit Size
Drywall, Plaster, Wood Paneling	QTY (2) McMaster-Carr #97121A013	Rounded head Toggle Bolt · 6-32 · 3" long · 1-1/2" wingspan toggle · Pull Out Strength: 35 lbs	3/8"
Block, Brick, Concrete	QTY (2) McMaster-Carr #97026A021  AND  QTY (2) McMaster-Carr #91555A111	Metal Anchor for Block and Brick · 1" long · Pull out Strength: 60 lbs  AND  Rounded Head Screw · No. 6, 7 or 8 sheet metal or wood screw · 2" long	1/4"
Electrical Box or Duct	As recommended by the manufacturer of the box or duct		N/A

5. Tighten the mounting bolts or screws to 8.7 in-lb (1 Nm) maximum.
6. Remove the metal grounding plate before removing knockouts.
7. Remove one of the knockouts (depending on where cables will enter the housing) and affix appropriate conduit.
8. Run wiring through the conduit and the housing to the monitor. (See wiring section).
9. Reinstall the PCBA.
10. Install the sensor cartridge.
11. Complete wiring as shown in the *Wiring* section.
12. Close the cover and tighten the cover screws to 29.7 in-lb (3 Nm).
13. Restore power to the monitor.

1998-0767  
Revision 7  
May 2019

**Honeywell**  
THE POWER OF CONNECTED

## Mounting for Remote monitor

The E3Point Remote Monitor is designed to be mounted in an extra wide (2 3/8") electrical box (not supplied) in the same way as a faceplate. Suggested electrical boxes include T&B BC1110, Hubbell 1110, OZ-Gedney 18112, Appleton 18112, Bowers 10612-BW, or Steel City 68371-12.

It does not fit on 4x4" steel boxes with a single gang mud ring, such as T&B 52CO or 52C13.

- Run the wires through the electrical box and connect to the remote monitor.
- Press the monitor (2) into the faceplate (1) and close and press the back cover (3) into the faceplate. You should hear a click.
- Securely mount the monitor to the extra wide electrical box (4) using the appropriate screws (5)(not supplied).

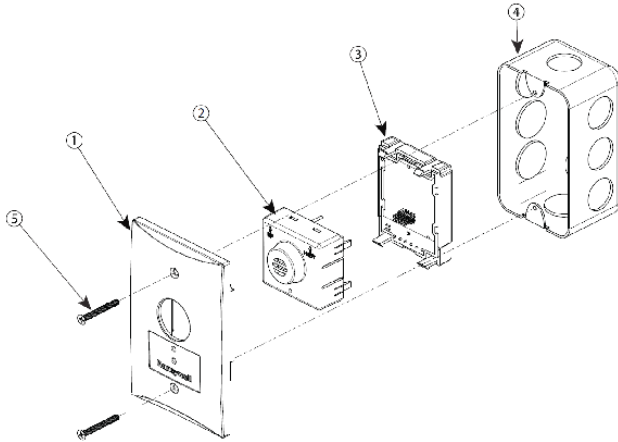

## Wiring

Follow local codes when sizing power wiring:

- Terminal Blocks, input, and communication: R/C (AVLV2) AWM minimum 300 V, 10 A, 16-22 AWG solid or stranded
- Terminal blocks relays: R/C (AVLV2) AWM minimum 300 V, 10 A, 14-22 AWG stranded, 16-22 AWG solid
- All communication wiring should be shielded.

Network cabling can extend up to 2000 feet (609 m) per channel. Daisy chain the network cable without T-taps. The 24V supply must be properly grounded in accordance to all local electrical codes. Power wiring must be grounded with a terminal ring at the screw and nut on the grounding plate inside the case.

## Wiring Standalone monitor

Ground the shield at the main control panel. Connect the shield wire in the monitor terminal block labeled "shield." Tape all exposed shield wire at the monitor to insulate it from the enclosure.

## Detection Ranges and Alarm Levels

Gas Detected		Resolution	Range	Alarm A	Alarm B	Alarm C	Maximum Overload
CO *	Carbon monoxide	1 ppm	0-250 ppm	25 ±2 ppm	100 ±5 ppm	200 ±10 ppm	500 ppm
H <sub>2</sub> S	Hydrogen sulfide	0.1 ppm	0-50 ppm	10 ppm	15 ppm	20 ppm	150 ppm
NO <sub>2</sub>	Nitrogen dioxide	0.1 ppm	0-10 ppm	0.7 ppm	2 ppm	9 ppm	150 ppm
O <sub>2</sub>	Oxygen	0.1%vol	0-25%vol	19.5%vol.	22%vol.	22.5%vol	100%vol
H <sub>2</sub>	Hydrogen	0.5% LEL	0-100%LEL	25%LEL	50%LEL	90%LEL	100% LEL
CH <sub>4</sub>	Methane	0.5% LEL	0-100%LEL	25%LEL	50%LEL	90%LEL	100% LEL
C <sub>3</sub> H <sub>8</sub>	Propane	0.5% LEL	0-100%LEL	25%LEL	50%LEL	90%LEL	100% LEL

\*Sensor exposure to gas concentration that may result in permanent damage to the sensor

\*Tested by Intertek to UL 2075 for Sensitivity, Selectivity, and Electrical Supervision at 23 ±3 °C (73 ±5°F) and 50 ±20 %RH

## Circuit Board Connections

Connect the power wiring to terminal J1, communication wiring to terminal J2, and external devices (ventilators, strobes, etc. to relay terminals J5 or J6).

## Main Circuit Board Connections

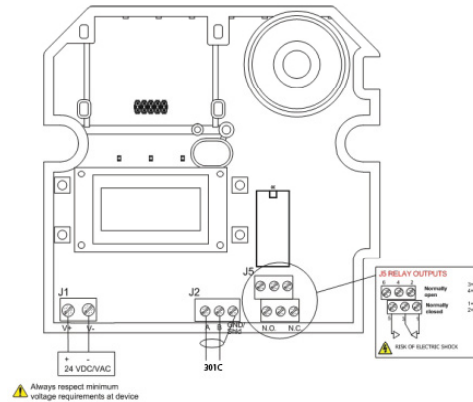

## 3-Wire Current Sink Output (DC supply only)

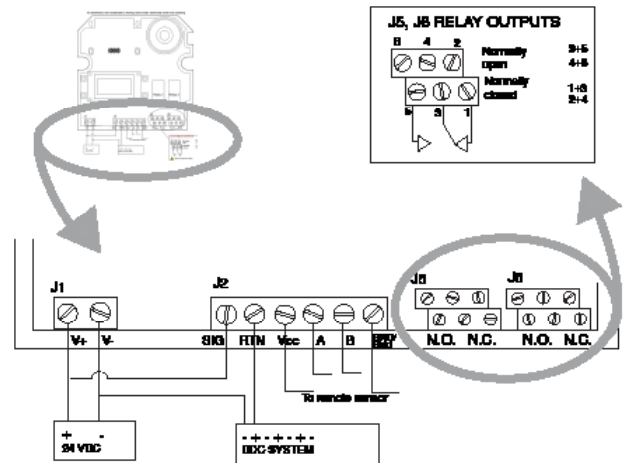

## 4-wire Current Sink Output

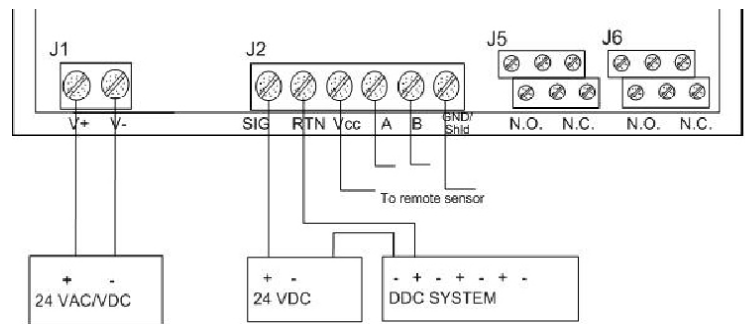

## 120 VAC Connection (model E3SAH only)

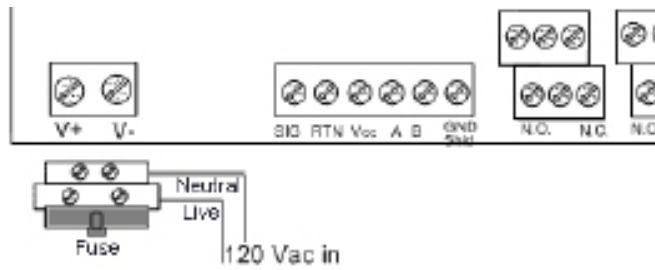

The transformer is mounted under the PCBA. Connections to terminal are factory wired. Connect the live and neutral wires, Verify that power is off before connecting wires. Replace fuse type: 1A 250 VAC, T.

## Connecting a Remote monitor to the Stand monitor

The remote monitor can be connected only to an E3Point stand monitor. For signal wiring, use shielded twisted pair cable. Remote monitors should have no more than 200 ft (61 m) wire.

The OUT1 and OUT2 connectors on the remote monitor's ter not used. Do not connect wires to these locations.

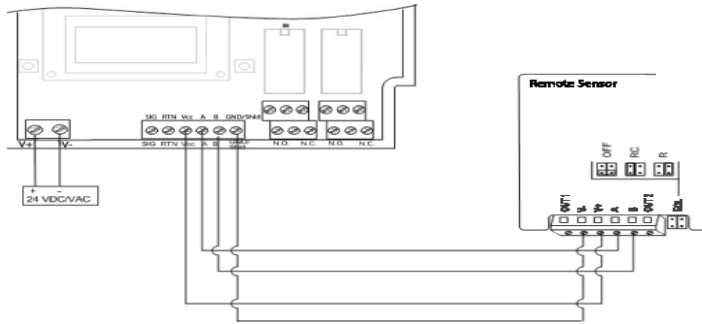

## Wiring Network Monitors

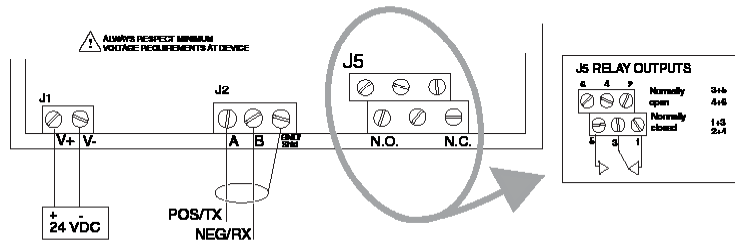

## Installing a Sensor Cartridge

Power to the E3Point Monitor must be off when installing a sensor cartridge.

Orient the cartridge with "UP/HAUT" toward the top of the monitor and gently press the cartridge into place. Do not bend the cartridge pins.

New cartridges do not require calibration. In California, follow local regulations.

## commissioning

System Validation Test or Commissioning of the gas detection system is not complete until it is tested to verify it functions according to its design objectives or specifications.

See Technical Manual for details.

Indicators	Description	Display modes
I/O	Power	Always on = Normal operation
		Always off = microcontroller fault or no power
		Blinking (twice per second) = self test
1	Standalone: Built-in Monitor	Always on = Alarm A triggered
	Network: Built-in Monitor	Slow blink (once per second) = Alarm B/C triggered
	Alarm A	Fast blink (4 times per second) = Fault
2	Standalone: Remote Monitor	Always off = normal operation
		Always on = Alarm A triggered
		Slow blink (once per second) = Alarm B/C triggered
	Network: Transmit	Fast blink (4 times per second) = Fault
		Always off = normal operation
		Always on when transmitting, blinks for communication
	Always off = normal operation	

## Final Test

After all of the monitors in a system have been installed, perform a final test. The installation is not complete until all components perform without fault codes.

All E3Point network monitors must appear on the controller's display without fault codes. Change the Modbus address for each monitor before forcing the controller to scan the network.