



Best Practices for Gas Monitoring in the Commercial Kitchen

Enhancing Kitchen Safety through Strategic Gas Monitoring



“Commercial kitchens are one of the most hazardous commercial building areas.”



Overview

The commercial kitchen is a hazardous area that should be monitored for both toxic and combustible gas hazards. Whether natural gas or propane is used for combustion, a variety of cooking equipment (e.g. stoves, grills and fryers) present a constant flammable danger to workers. In addition, carbon monoxide (CO), the by-product of incomplete combustion, can be present at unsafe levels. Over the last twenty years, standards for CO monitoring have been developed, with first-alarm levels typically set at 25-35 parts per million.

Today more rigorous standards for gas monitoring are being developed; those driving regulatory change vary by state but include many: building inspectors, consulting engineers, insurance adjustors, fire marshals, and life safety experts. More legislation is inevitable in light of the sobering statistic that 25% of all fatalities in commercial buildings are due to carbon monoxide poisoning. What's problematic is, CO is odorless, so rising CO levels are difficult to detect by humans. According to medical research, just 0.1% CO in the atmosphere can adversely affect concentration. At 2% CO levels, breathing reduces to about 50% of the normal rate. Once levels rise to 5-10% people quickly become confused and can lapse into unconsciousness.

The commercial kitchen presents a special case for more rigorous CO monitoring, as there is a greater risk of CO poisoning from both long-term, low level exposure as well as short-term, high-level exposure of CO concentration levels.

The First Step: Choose Commercial-Grade CO Detectors

The CO detectors recommended should be commercial-grade detectors. Be advised that most residential-model CO detectors are not equipped with the same sensing performance, diagnostics and configurable options as commercial-grade offerings.

A key point to note: a commercial detector will trigger immediately at a pre-determined set point; however, many residential units alarm only after a time-weighted duration of over 60 minutes. In addition, the commercial-grade CO detector also will alarm under any of the following conditions: loss of power, automatic self check of internal electronic system & sensing element (including a sunset feature). According to most state codes, a commercial-grade CO detector must detect the gas (and sound the alarm) at a lower level than a residential-use detector.

Providing kitchen personnel with the highest assurance of effective protection from carbon monoxide poisoning should be the goal of every kitchen manager. That higher standard of safety can be realized through one of two system designs: the redundant gas monitoring system (CO/CO) or a dual gas monitoring system (CO/CH4).

Commercial Cooking Venting Requirements



Option #1:

Fan Proving System with Internal Manual Reset Valve

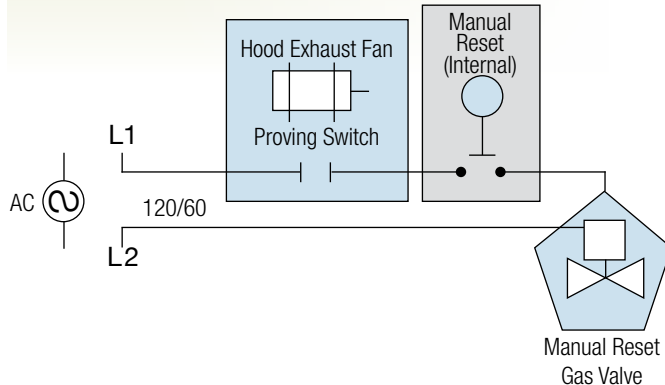

Under the NFPA (54) Code 10.3.5.1 & 10.3.5.2 (2002), ventilating hoods and exhaust systems shall be permitted to vent gas-fired equipment installed in commercial applications. However, certain requirements must be met, including:

- These same requirements apply for systems with standing or electronic pilot ignitions.
- A valve shall be located on the main gas line feeding the appliances served by the gas hood and shall stop the flow of gas to the appliances upon loss of draft. No by-pass of the gas solenoid valve is allowed.

Where automatically operated gas utilization equipment is vented through a ventilating hood or exhaust system equipped with a damper or with a power means of exhaust, provisions shall be made to allow the flow of gas to the main burners only when the damper is open to a position to properly vent the equipment and when the power means of exhaust is in operation

Option #2:

Fan Proving System with External Manual Reset

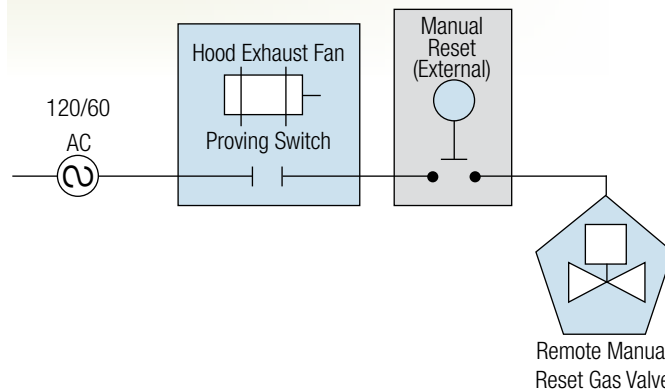

- The gas valve must be controlled by a draft proving switch measuring draft within the hood. The gas valve is allowed to be open only when the fan is operational or the damper is 100% open.
- The gas valve shall be equipped with a manual reset (integral or otherwise). The valve must be manually reset only when the lock-out condition is corrected. The reset cannot be automatic.

Under current kitchen management practices, there are at least three ways to satisfy these requirements:

Option #3: Most Advanced Design

Redundant Gas Monitoring System with External Manual Reset Valve

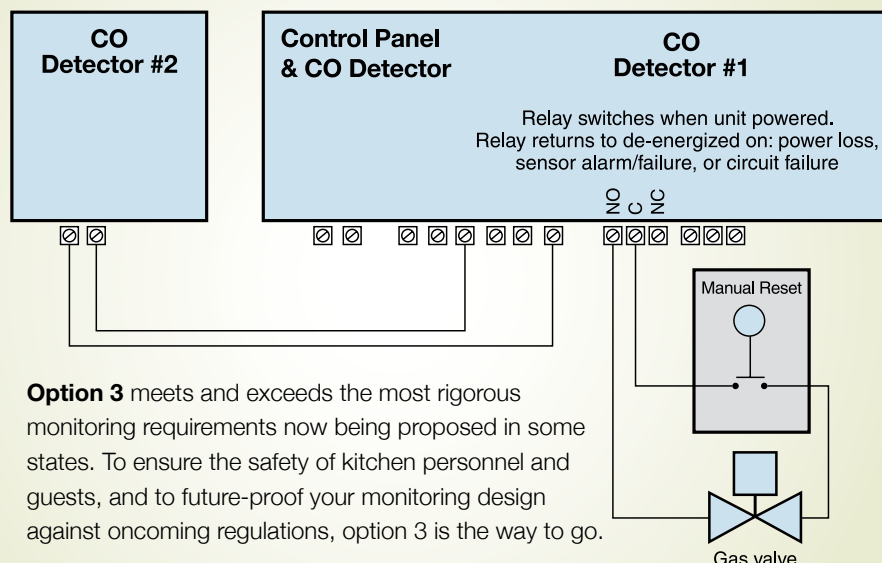

Option 3 meets and exceeds the most rigorous monitoring requirements now being proposed in some states. To ensure the safety of kitchen personnel and guests, and to future-proof your monitoring design against oncoming regulations, option 3 is the way to go.

Option 1: Fan Proving System with Internal Manual Reset Valve

Option 2: Fan Proving System with External Manual Reset

Option 3: Most Advanced Design - Redundant Gas Monitoring System with External Manual Reset Valve

The shortcomings to options 1 and 2 are:

- No bypass is allowed according to NFPA code
- Hood switches notoriously fail in this environment and are easily jumped out or set incorrectly
- The problem of back draft of damper system is not addressed

Best Safety Practice: Adopt Either a Dual-Gas Or Redundant Gas Monitoring System



“Two CO monitors strategically installed ensure a higher degree of safety if one monitor should fail.”

The Redundant CO Monitoring System: a Case for Wider Implementation

A system that uses at least two CO (carbon monoxide) detectors as part of a gas monitoring system design is strongly advised. This dual-sensing or redundant gas monitoring design meets the requirements of NFPA 54 10.3.5.2.

Under the current code and clarifications, a kitchen's gas valve is allowed to remain open, even if the hood's exhaust fan is off, provided that a proper carbon monoxide detector is monitoring the space. However, an *intentionally* redundant second CO monitor has been shown to increase the reliability of the system design, ensuring the probability of continued safety in the event that one monitor fails. In many hazardous industries, this fail-to-safe design feature is now mandated as a prerequisite to obtain a work permit; these regulations are the outcome of painful lessons learned too late. The commercial kitchen, in effect, functions as a small power plant, consuming up to 60% of the energy load in a commercial building. In this light, a CO monitoring system should be viewed properly as a life safety system. A redundant CO monitoring system for the commercial kitchen mitigates risk to human life by increasing the margin of safety. In conclusion, the oft-repeated counsel for choosing a CO monitor based on its square foot coverage should not be the sole means of determining how many detectors are needed in the space!



When installing a redundant CO monitoring system, certain criteria should be met:

- When the CO monitor fails (or sunsets), according to NFPA code the gas valve shall be closed and remain so until the device is replaced. No gas bypass is allowed to feed standing pilots.
- Air sampling from the CO detector should be taken from a minimum of two separate locations. Again, it should be noted that the square footage of the kitchen should not be used as a reliable guide to the number of CO monitors required for adequate coverage. The exact number of CO detectors should be determined after a site evaluation and in close consultation with gas monitoring system design engineers.
- The CO detectors shall be interlocked with the gas valve. The gas valve shall be equipped with a manual reset (integral or otherwise).
- An audible alarm shall sound when pre-determined levels of CO are reached.

Installation Considerations



Locating the Sensor

Installation Height			
Detected Gas		Relative Density (air = 1)	Installation Height
CO	Carbon Monoxide	0.968	1-1.5 m (3-5 ft.) from floor
COMB	CH ₄	Varies*	Varies*

* **Note:** Most combustible gases are heavier than air, with the exception of methane, hydrogen, ethylene and acetylene. Sensors for gases that are heavier than air should be installed approximately 30 cm (1 ft) from the floor. For combustibles that are lighter than air, sensors should be installed 30 cm (1 ft) from the ceiling, close to the potential leak source. For guidance on combustible gas monitoring, consult a gas monitoring system design expert.

In a commercial kitchen, special consideration should be given to the following installation requirements:

Locating CO Detectors

To determine the best locations for installation of CO detectors, the main considerations are installation height and detection objectives. If the primary application is to obtain the fastest possible leak detection, the standard practice is to mount the sensor near the potential leak sources. A drawback to this approach: the indicated concentration may not be representative of personnel exposure, and easy access for the required calibration and maintenance can be compromised. A common error

in the commercial kitchen is installing the sensor too close to the hood. This is problematic because heat and grease build-up in the hood can produce faulty readings as well as block the sensing element. To offset this problem, the recommended practice is to mount the sensor ten feet from the hood. The disadvantage to this practice, however, is that it puts the sensor further from the source of potential combustion. As the old adage goes, you can't have it both ways; thus, the need for two CO sensors, or a redundant gas monitoring system.

The Dual Gas Monitoring System (CO/CH4)

Sequence of operation: A dual-gas monitoring system for the commercial kitchen uses a combustible gas detection sensor as a remote monitoring source that can be connected to a primary CO detector, allowing for both combustible and toxic gas monitoring on a single platform. The primary unit here is mounted a few feet from the floor, within "the breathing zone" for CO, while the remote unit is positioned above the cooking equipment to detect CH₄, which has lighter-than-air properties.

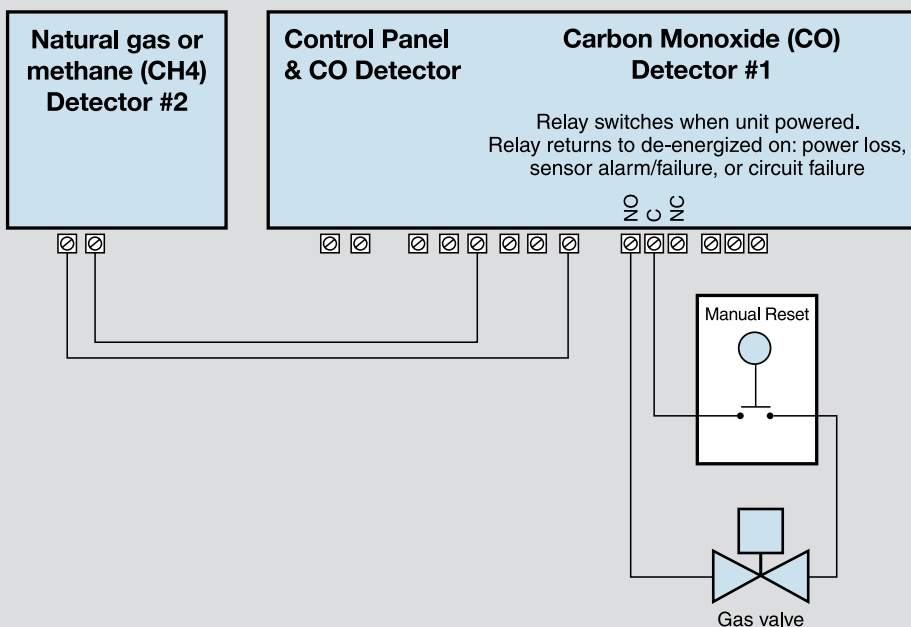

Installation Height: The two CO detectors should be mounted in the kitchen approximately 5 feet from the floor. This five foot height corresponds to the "breathing zone" of most people and is adopted as the de facto standard. CO is relatively the same weight as ambient air.

Regulatory Codes and a Summary of Best Practices



Lawmakers are Turning up the Heat on Commercial Kitchen Safety

In 2012, the NFPA upgraded its Standard 720 for the Installation of Carbon Monoxide (CO) Detection and Warning Equipment to include the following clarifications:

- **5.8.5.3.5** The location of carbon monoxide detectors shall be based on an evaluation of potential ambient sources and other criteria (e.g. flows of carbon monoxide, moisture, temperature, dust, or fumes and of electrical or mechanical influences to minimize nuisance alarms).
- **5.8.5.3.6** The selection and placement of [carbon monoxide] detectors shall take into account both the performance characteristics of the detector and the areas into which the detectors are to be installed to prevent nuisance alarms or improper operation after installation. [72:17.7.1.7]
- **9.4.1.2** Each alarm or detector shall be located on the wall, ceiling, or other location as specified in the manufacturer's published instructions that accompany the unit.
- **A.1.2** Carbon monoxide alarms and detectors are intended to alarm at carbon monoxide levels below those that are known to cause a loss of ability to react to the dangers of carbon monoxide.

Summary: Reducing Risk

Factors that will reduce risk of toxic or flammable gas incidents in the commercial kitchen include:

- Redundant gas monitoring system
- Good natural ventilation
- Satisfactory fume removal through ventilation ductwork by natural draught alone
- Well-maintained ventilation system
- Appropriate ventilation system interlock
- Good user awareness of the risks and proper documented safety procedures
- Proper use of gas-fired appliances
- Regular extraction cleaning of ductwork, filters and extractors
- Adequate room size for kitchen
- Notices warning that appliances must not be used without the ventilation system in operation



Be sure to use Commercial Grade Gas Detectors for protecting commercial kitchen staff and guests

Honeywell