

Application Note  
S1-568, S1-1068, S1-1568

**Megger**<sup>®</sup>



Insulation testing in power  
distribution networks and EHV  
transmission environments

**EN**

1.800.561.8187

www.**itm**.com

information@itm.com

## Introduction

The development of the insulation tester by Evershed and Vignoles is part of our electrical history, with insulation testers produced by Megger Instruments in the UK, dating back as far as 1897.

Voltage outputs for the Megger S1 range of insulation testers are available up to 15 kV to suit all industrial, power distribution and transmission applications. On these higher voltage testers incorporating very high insulation ranges, the guard terminal becomes a major benefit when testing assets that have large surface leakage areas of insulation. These include larger diameter cables, porcelain bushings, power transformers and HV circuit breakers. Such products exhibit long creepage paths across their insulation, due to the nature of their size, and the unwanted surface leakage resistance can cause defects. This is where the guard terminal can enhance the accuracy of the measurement.

In addition the 5 and 10 kV versions, the S1-568 and S1-1068 are equipped with advanced filter settings specially designed to work in the extra high transmission voltages in extreme environmental conditions.



# The S1 range of insulation testers

## What makes them special?

The Megger S1 range of 5, 10 and 15 kV insulation testers (identifiable by their distinctive red labels) have been designed specifically for the power utility market.

Specifically they can cope with the high noise  $\geq 400$  kV environments combined with the extreme environmental conditions. Extremes in temperature and humidity present particular challenges for an insulation tester in high noise environments.

## What sets the S1 range of insulation testers apart from other insulation testers?

Averaging filters, how they work and their use during PI and DAR tests

All Megger S1 insulation testers feature four averaging filters. While the instruments hardware filters can remove the 50/60 Hz element of the noise current it cannot remove the remaining slow variation. The averaging filters store up all the measurements made by the instrument in the set time period and then display the average of those measurements. From there, the reading becomes a rolling average.

The effect can be seen in example below:

### Effects of rolling average filter explained

Measurements (G ohms): 10.5 15.0 10.0 12.0 15.5 11.0 20.0 15.0 10.0 8.0 12.0 15.0 15.0 14.0 15.0 11.0 20.0 15.0 15.0 10.0 20.0 15.0 20.0 15.0 19.0 10.0 22.0 15.0 25.0  
Averaging filter applied: 10.5 12.8 11.8 11.9 12.6 12.3 13.4 13.6 13.2 12.7 12.9 12.9 13.4 13.6 13.5 13.5 13.5 13.5 14.0 14.2 15.0 15.0 15.5 15.6 16.0 15.9 16.1 16.1 17.1

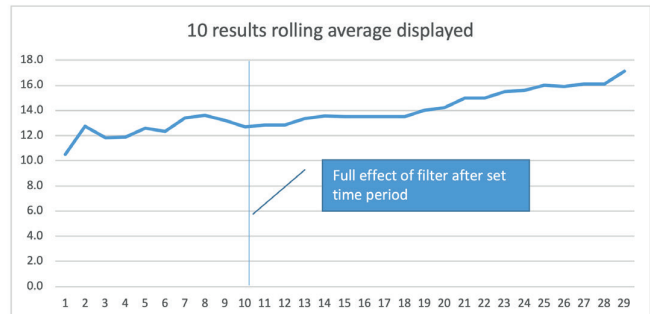
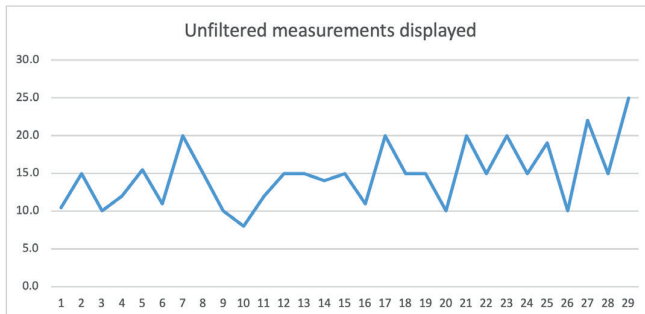

## The S1 range of insulation testers

The S1-568 and S1-1068 models can also apply averaging filters to a DAR or PI measurement. The application of averaging filters will modify the DAR or PI values (hence the warning triangle appears on the display during the testing), but provided the same averaging period has been used on subsequent measurements the results can be used for comparison and for highlighting insulation degradation.

To select an averaging period the operator must press the filter button before the DAR or PI test commences. Once the test has commenced the averaging period cannot be changed. To provide suitable comparative PI values the same filter setting has to be used throughout the test.

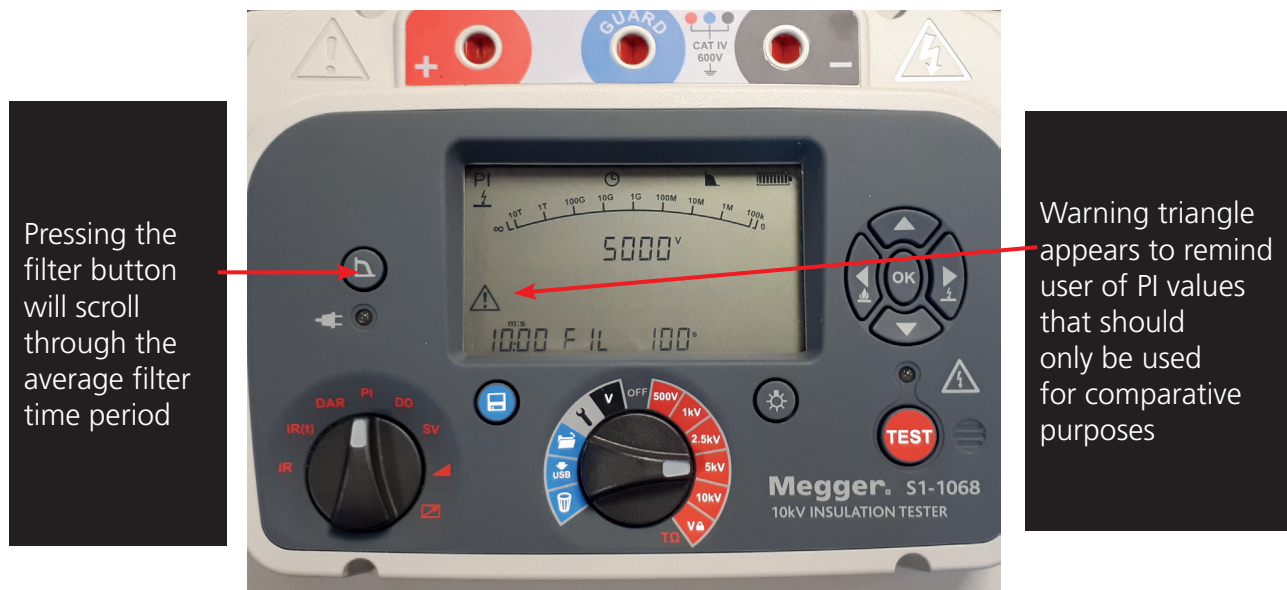

### Advanced filter settings and negative currents

The S1-568 and S1-1068 are also equipped with an additional advanced filter setting specially developed for working in very high voltage environments that can suffer with sudden transient changes in noise current. The advanced filter settings allow the user to select either the normal hardware filter, or a new adaptive filter, or even both. The new adaptive filter allows the instrument to automatically adjust to deal with these sudden changes in noise current.

One important feature is how the instrument deals with negative test current. Occasionally sudden changes in induced noise current can result in the instrument trying to measure a negative current. Attempting to calculate a resistance value from a negative current will clearly provide totally invalid and inaccurate resistance measurements.

The S1-568 and S1-1068 has the ability to ignore these values and displays "neg" to indicate this is happening to the operator.

# The S1 range of insulation testers



It can be seen here that the test current has been forced negative

The advanced adaptive filtering should not be switched on or off during a measurement. Instead this is selected in the settings (spanner) mode as follows:

Press up / down buttons to scroll through options

X on display indicates change.

Advanced adaptive filter ON only

Hardware filter ON only

Both Filters ON

Press OK to select option X turns to a tick to confirm



# How to get the best out of the Megger S1 range of insulation testers

## What are they? How are they used?

The Megger screened test leads available for use with the S1 range of insulation testers have a negative (black) test lead screened, with the screen itself connected to the guard terminal of the instrument. The positive (red) test lead is not screened. This is because the positive lead is, in power applications, always connected to ground/earth. In fact, the guard terminal of an insulation tester is a key component of a successfully screened test lead. The guard terminal should ideally be of lower input impedance than the negative terminal, simply to ensure all noise current is successfully diverted away from the sensitive measurement circuit.

Later in this application note the operation and importance of the guard terminal is discussed, however, in the meantime, let's take a look at the screened test leads.

## Anatomy of Megger screened test leads:



# How to get the best out of the Megger S1 range of insulation testers

## Basic connections

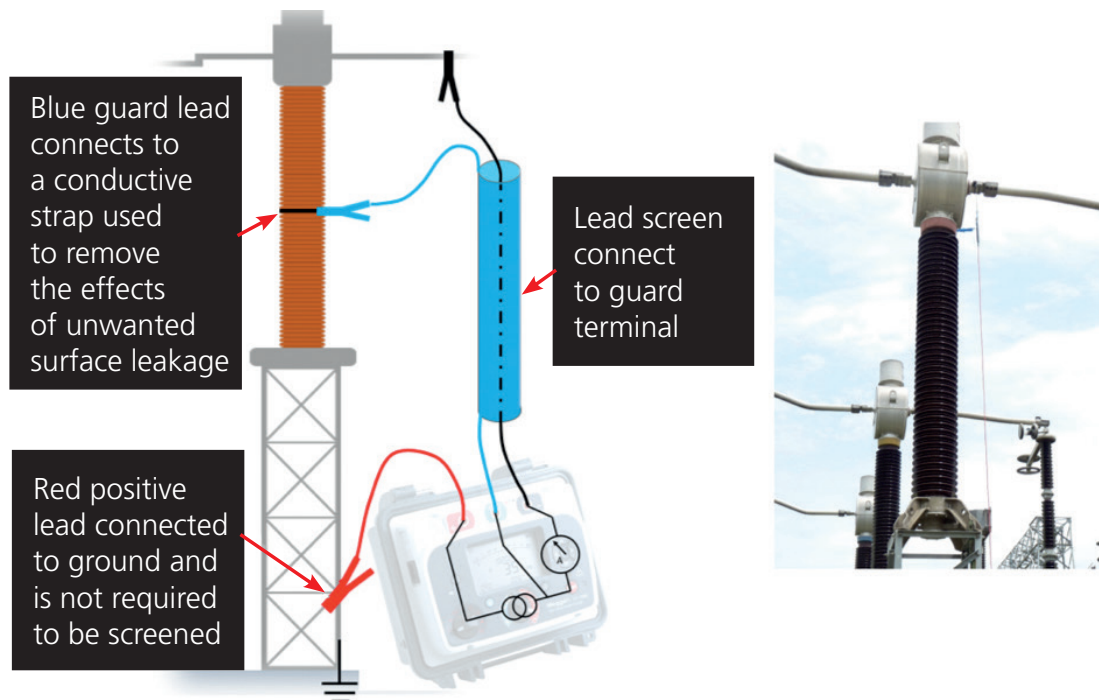

Some rules to observe when using screened leads in HV environments:

- Do not let any test leads touch each other
- Do keep the screened lead close to any grounded metalwork (it will capacitive couple some of the noise current to ground)
- Do not let the screened lead touch the equipment
- Do not touch test leads during a test

## Safety Warnings

- Do not disconnect test leads without safety grounds in place
- Only make connections when the test piece is fully grounded for safety

Screened leads can be used on many apparatus, however the theory is always the same. Electrical interference, or noise as it is often referred as, which would have been picked up by test leads and conducted through the measurement circuit is picked up instead by the screen. The screen then safely conducts the noise current through the guard terminal bypassing the instrument's sensitive measurement circuit.

The screened leads can remove the noise-current induced into the test leads, but they cannot remove the noise current induced directly onto the test piece. This is where a carefully designed filter circuit is important, one backed up with a fully specified noise immunity specification.

# How to get the best out of the Megger S1 range of insulation testers

## Noise immunity performance specification explained

Megger has always fully specified the noise immunity of our S1 range of insulation testers. The specification is in terms of current simply because it is the current measurement of the instrument that is most likely to be disturbed by any noise issues. The S1 range of insulation testers can measure insulation resistance with a noise current of up to 8 mA ac flowing through the measurement circuit.

To explain this please see the following diagram:

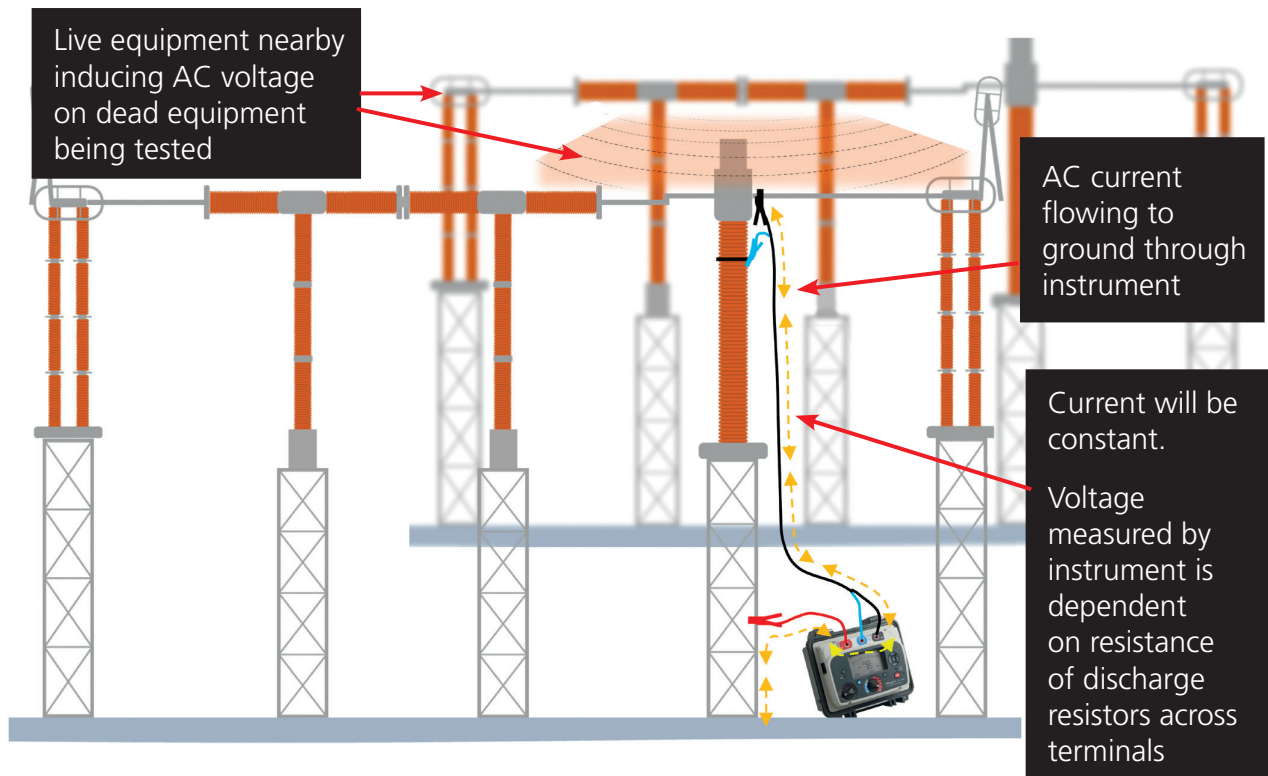

## Induced current and resulting voltage measured by instrument

In the diagram above it can be seen that voltage is induced into the isolated line by adjacent equipment still live. When the instrument is connected it will measure a voltage across the test terminals. The voltage will be such that it tends to drive a constant current through any resistance to ground.

Insulation testers always have a set of discharge resistors connected across their terminals for safety reasons. The instrument measures the voltage across these resistors, which will depend on the current. This is why sometimes different instruments measure different voltages on the same circuit. The value of this discharge resistance is usually kept quite low as it determines how fast the instrument can discharge the potentially lethal charge left following testing a long power cable.

## How to get the best out of the Megger S1 range of insulation testers

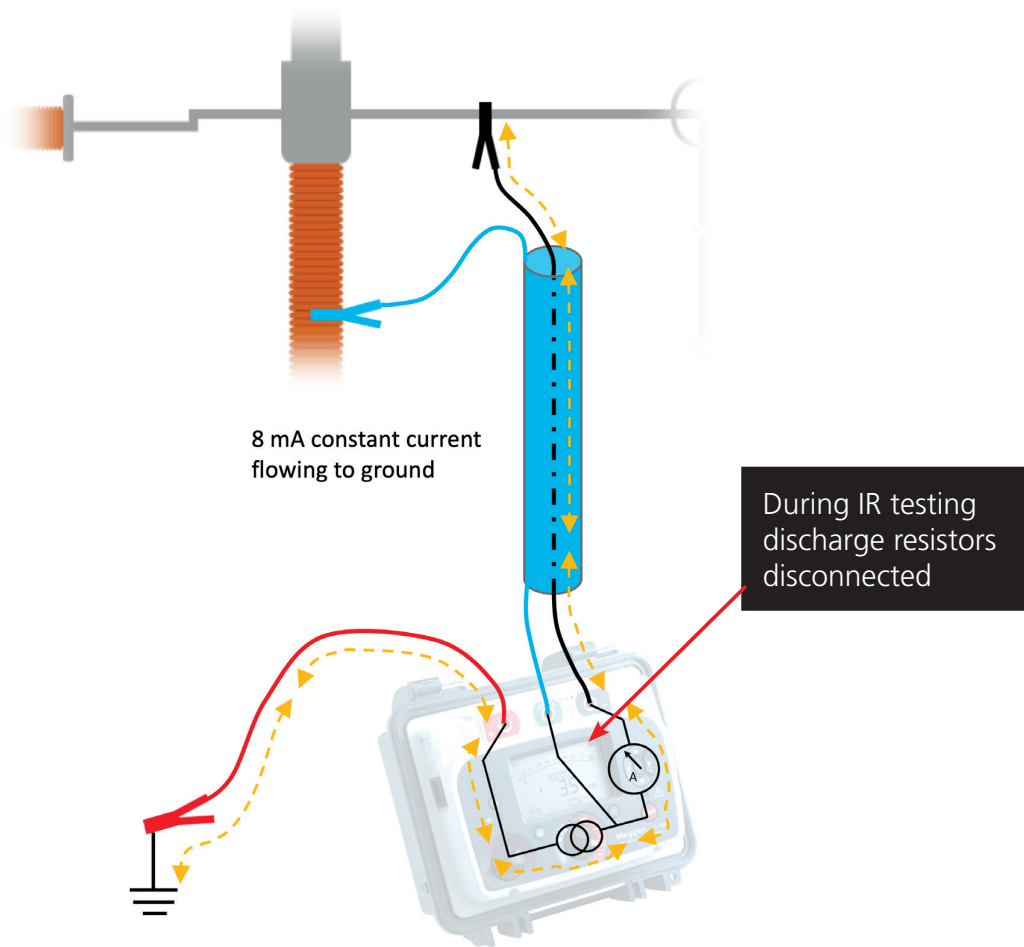

When the insulation tester is first connected the instrument will detect voltage and measure it as a safety warning. In this example an S1-1068 has a discharge resistance of 41 k $\Omega$ , so if 8 mA of noise current was flowing through the instrument to ground it would be measuring 328 V.

## How to get the best out of the Megger S1 range of insulation testers

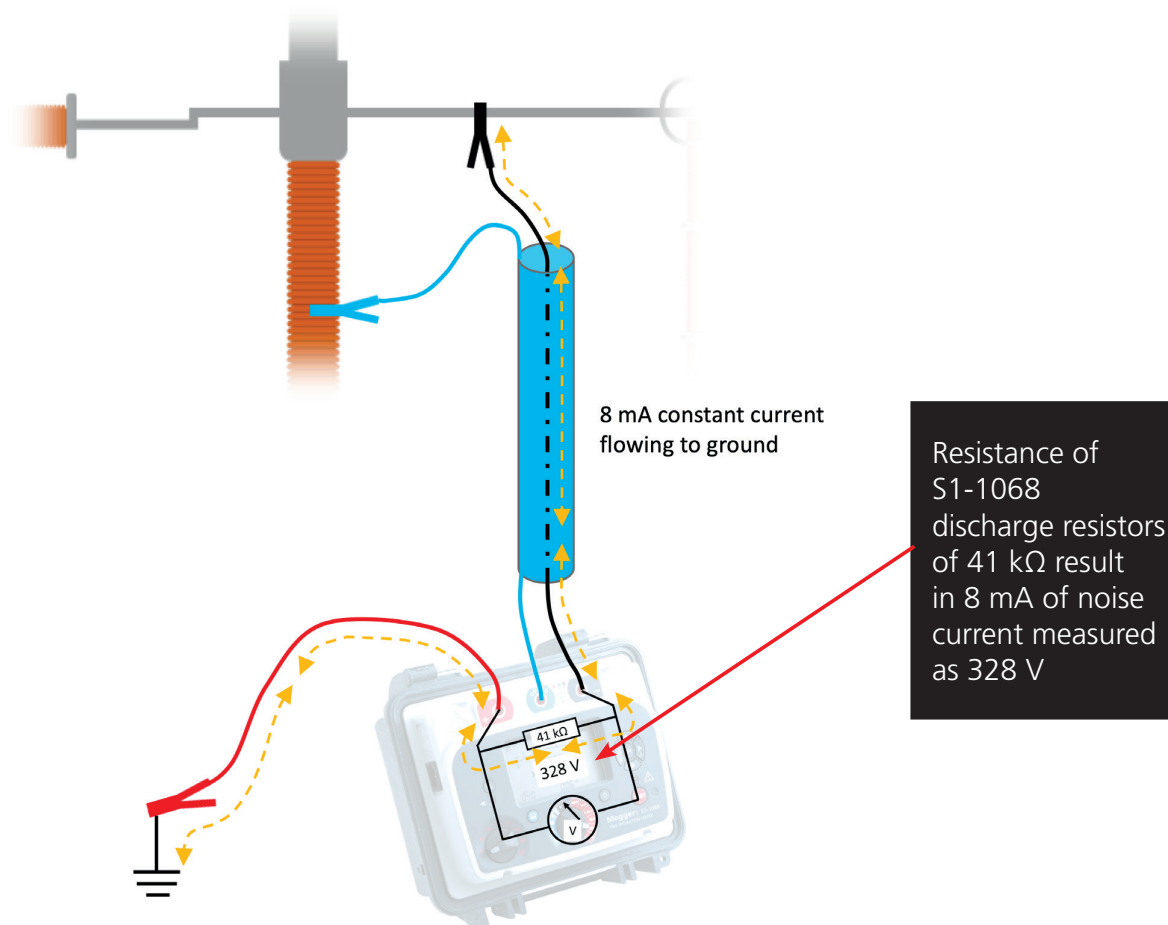

Once the test button is pressed and the IR test proceeds a relay is powered up to disconnect the discharge resistors (relay is powered open so it would fail safe in the event of power loss)

## How to get the best out of the Megger S1 range of insulation testers

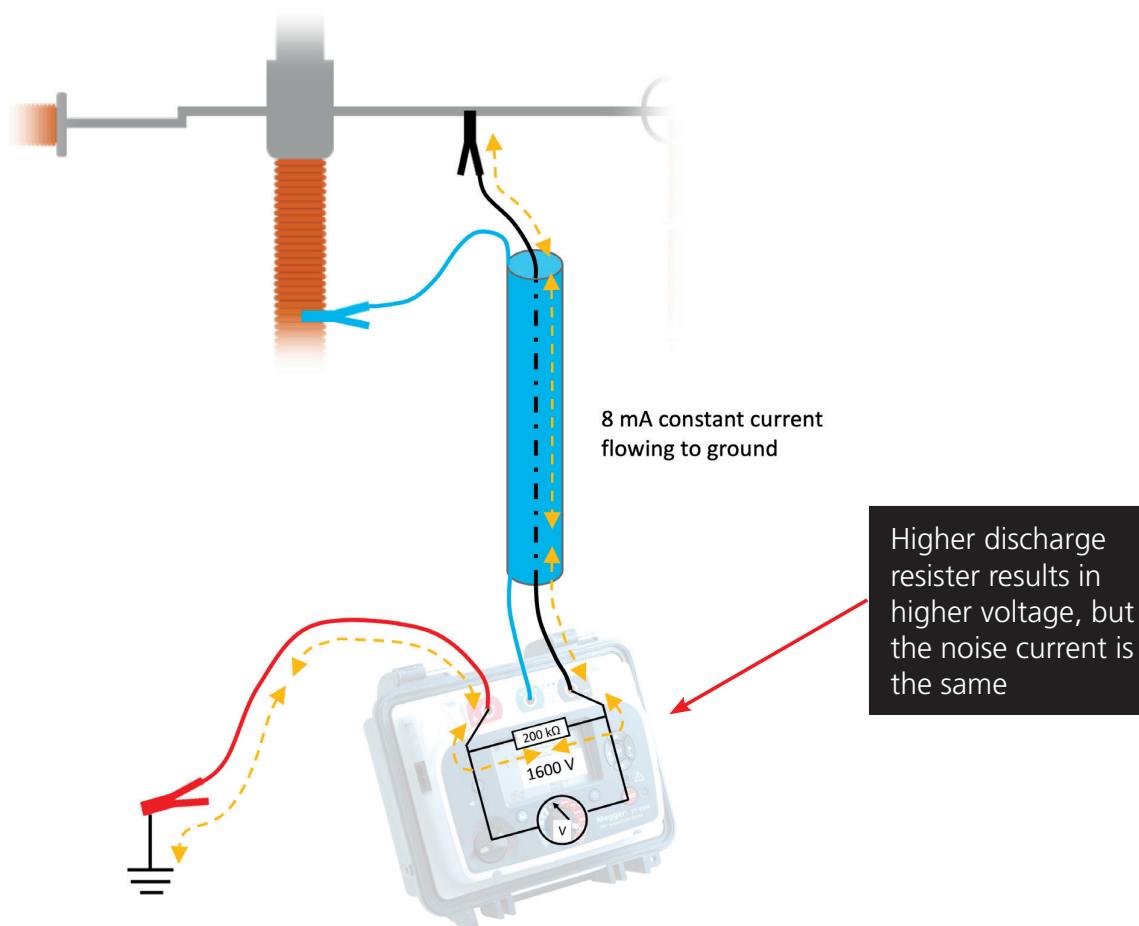

Some manufacturers use a much higher resistance in the discharge circuit to allow the use of lower power resistors. However as can be seen in this example it results in a much higher voltage measured.

The advantage of lower discharge resistance values are:

- Less voltage on terminals, which makes it much safer for the operator
- When the instrument is used for testing long power cables, the instrument will be able to safely discharge the lethal charge much quicker

**Safety: NEVER disconnect any test leads without the test piece fully and reliably grounded. Since the noise is derived from a high energy source, it is lethal and will try to maintain the same current regardless, meaning the OC voltage could rise to very high levels and even draw large arcs.**

# How to get the best out of the Megger S1 range of insulation testers

## Other considerations when testing in EHV environments

Testing in EHV environments present a number of challenges. So far the high level of noise current flowing through the instrument has been discussed, but what is the actual effect on the instrument and what should the operator consider and do about it?

We know the operator will know the amount of noise current present from the voltage measured across the discharge resistors; a simple Ohms law calculation will also tell you exactly how much is flowing. In fact, it is always worth noting down the voltage/current as a reference for future comparative measurements, just as we would note the humidity.

## Slow variation in induced and leakage currents

During an insulation resistance test there are a number of changes taking place, many of which are expected, such as the rapid initial increase in resistance due to capacitance, and the slow increase due to dielectric absorption. There might even be some irregularities in dielectric absorption or partial discharges causing some less than trending changes.

However, in the EHV environment, there can be seemingly random and sometimes dramatic variation in measurements. There are two reasons for this relatively slow, erroneous variation in IR measurements:

1. Variation in induced currents
2. Variation in surface leakage currents

Noise current is rarely constant due to effects of partial discharges, and the surface leakage current will change with the prevalent changes in wind and exposure to sun between clouds. Current will flow across the surface of insulators, and the amount will depend on the level of contamination and the ambient humidity. In addition, the test voltage applied can gradually dry out the insulation and therefore gradually increase the insulation resistance values.

The overall result can be considerable variation in measurement from both leakage current and noise current variations.

So what can be done by the user to remove these effects? The slow variation of noise current cannot be dealt with easily by a hardware filter, so the solution is the averaging filter that was discussed earlier. This will also help with the variation of surface leakage, but the surface leakage will result in the IR measurement being much lower than it should be. The far better solution is to remove the effects of the surface leakage current altogether. This is where an effective guard terminal is useful, together with the right test lead connections.

This is fully discussed in the next section and highly important in obtaining useful IR measurements.

# How to get the best out of the Megger S1 range of insulation testers

## Negative test currents in EHV environments

In the EHV environment variations can be quite extreme, so much so that occasionally the noise current can force the instrument measured current down so far it becomes a negative value. You cannot calculate an insulation resistance value using a negative current as you would get a negative resistance having a huge effect on the ongoing averaging filter results.

As mentioned earlier the S1-568 and S1-1068 models have the unique capability to ignore these negative values and to inform the operator it is doing this by displaying “neg” while it is happening.

With the advanced adaptive filter switched on, the S1-568 and S1-1068 models greatly limit the huge effects of negative currents.

## Transients in EHV environments

Another problem experienced in the EHV environment while insulation testing, are the transients caused by the partial discharges in the air. Air breakdown and ionisation currents increase with humidity. Therefore, severity depends on how high the transmission voltage is and the level of humidity in the air. Partial discharges are, of course, much worse in the high humidity experienced during the Indian monsoon season and you can tell this simply by the louder crackling sound. These transients can be very disruptive to testing resulting in even more variations in measurement.

The S1-568 and S1-1068 instruments are equipped with an advanced adaptive filter that may be switched on when required. The adaptive filter is carefully designed to remove the effects of transients without damping the sensitivity of the instrument to changes in leakage current.

The setting is accessed through the setting menu as shown below:-

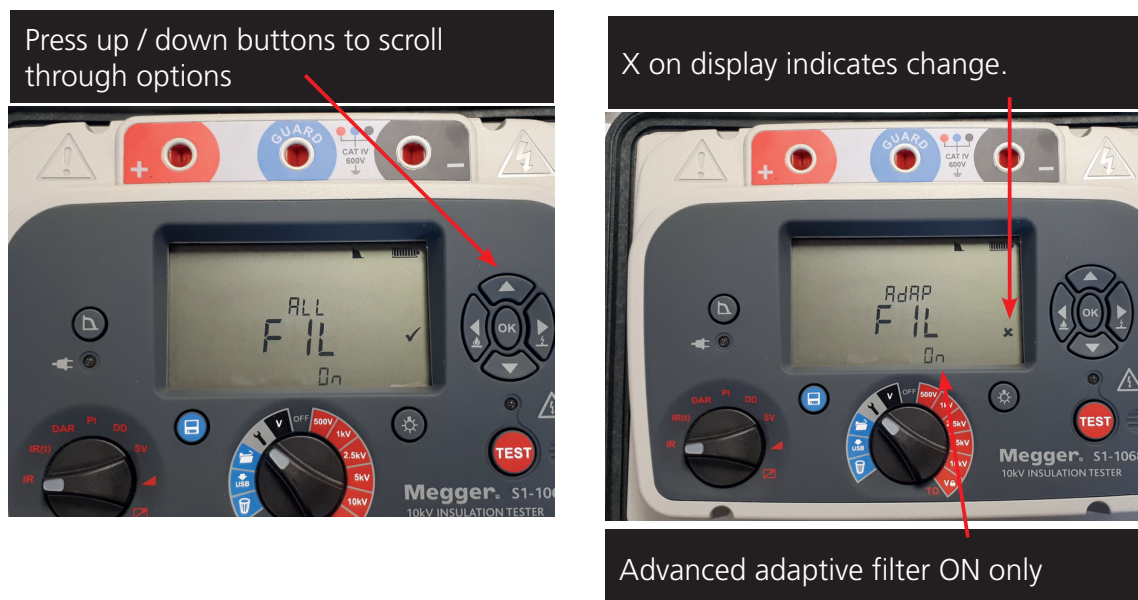

## How to get the best out of the Megger S1 range of insulation testers



The advanced adaptive filter can be switched on and off because it is not suitable for all IR testing. An example would be when testing motors or cables where it would be beneficial to detect and see the variation caused by a partial discharge or faster variation in absorption current. In this situation, the user may wish to switch off the adaptive filter to provide maximum sensitivity. There is an option to switch off both hardware and adaptive filters, but this is only used for very low noise applications that require a faster response.

Generally in the transmission voltage environment the best results will be obtained with both filters, hardware and adaptive filters in the settings menu switched on and the averaging filter activated too. This will provide maximum stability in this arduous environment.

# How to get the best out of the Megger S1 range of insulation testers

## What does a guard terminal do other than connect to the screened lead?

During insulation testing, the resistance path on the outer surface of the insulation material often gets neglected. However, this resistance path is very much a part of the measurement and can dramatically affect the results. For example, if dirt is present on the outer surface of a bush, the surface leakage current can be up to ten times that flowing through the actual insulation.

The surface leakage is essentially a resistance in parallel with the true insulation resistance of the material being tested. By using the guard terminal to perform a 'three-terminal test', the surface leakage current can be ignored. This may be important when high values of resistance are expected, such as when testing high voltage components like insulators, bushings and cables. These tend to have large surface areas that get exposed to contamination, resulting in high surface leakage currents across them.

The total current that flows during an insulation resistance test is made up of three main components:

1. The charging current, which charges the object's capacitance
2. An absorption current, which is the current that is being drawn into the insulation by the polarising of the molecules; initially high, but drops over time at a slower rate than the charging current
3. The conduction or leakage current, which is the small steady state current that divides into two parts:
  - 3.1. The conduction path through the insulation
  - 3.2. The current flowing over the surface\* of the insulation.

*\*Surface leakage is what needs to be excluded if just the insulation resistance measurement of the material is required. This can be done by using the guard terminal, which is available on most HV insulation testers.*

In applications with lower insulation resistance values (<100 MΩ), such as in LV building wiring applications, this is not necessary, but with values of insulation above the 100 MΩ, as found in HV insulation applications, the use of the guard terminal is often very important.

# How to get the best out of the Megger S1 range of insulation testers

## How does it work?

Here we have a typical application for the guard terminal testing an HV bushing. Without the guard terminal, the leakage current flowing through the bushing and across the surface is combined and therefore measured together by the instrument.

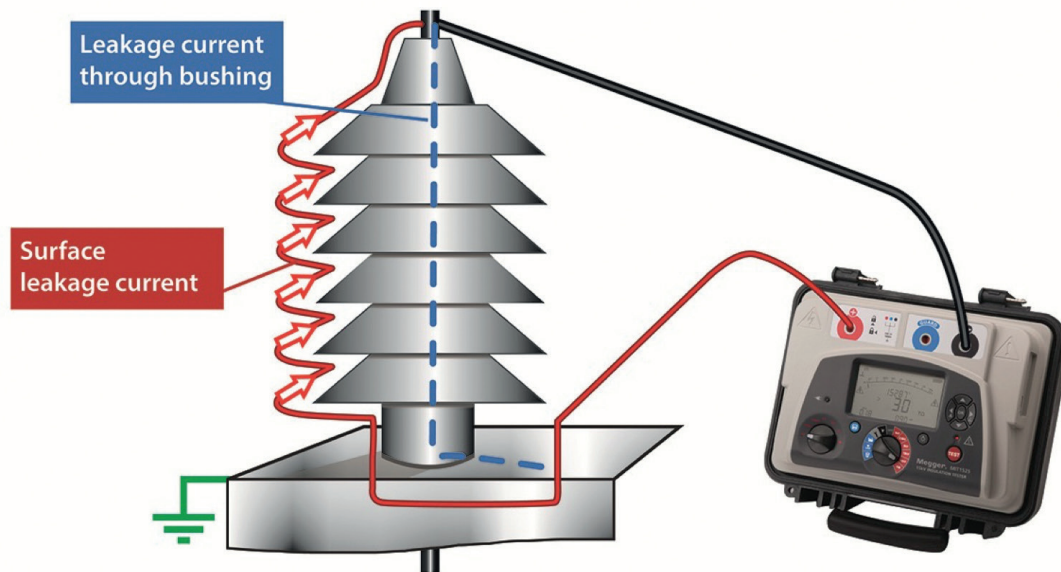

Now with the guard terminal in use:

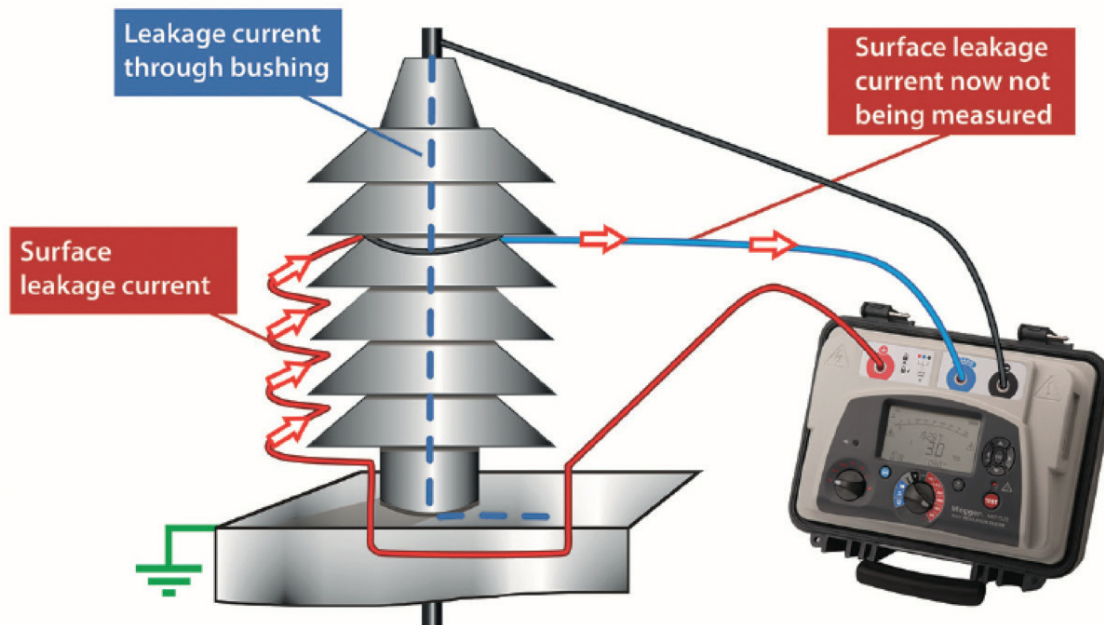

Wire has been wrapped around the centre of the bushing and connected to the guard terminal - now the surface leakage flows to the guard terminal. Current flowing into the guard terminal is not measured by the instrument and so is ignored by the insulation resistance measurement.

# How to get the best out of the Megger S1 range of insulation testers

To better understand what is actually happening within the instrument, we can look at the following diagrams. Put simply, the insulation tester has three main elements; the HV DC current source, the HV voltmeter and the ammeter. The insulation resistance measurement is simply Ohm's law; measured voltage divided by the measured current. The guard terminal allows leakage current to bypass the current measurement, and so be ignored in the measurement.

Firstly let's look at what happens if the guard terminal is not used:

## Guard not in use

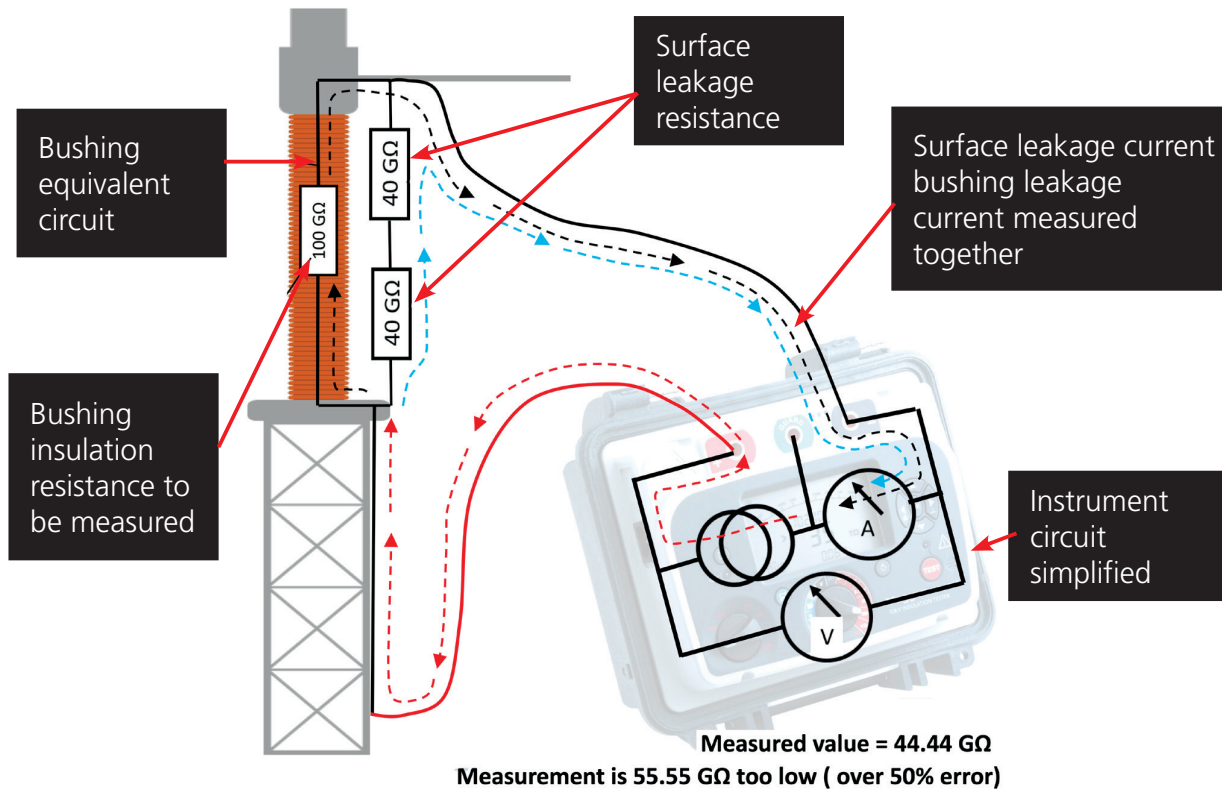

# How to get the best out of the Megger S1 range of insulation testers

Now with the guard terminal connected to a conductive strap wrapped around the bushing:

## Guard in use

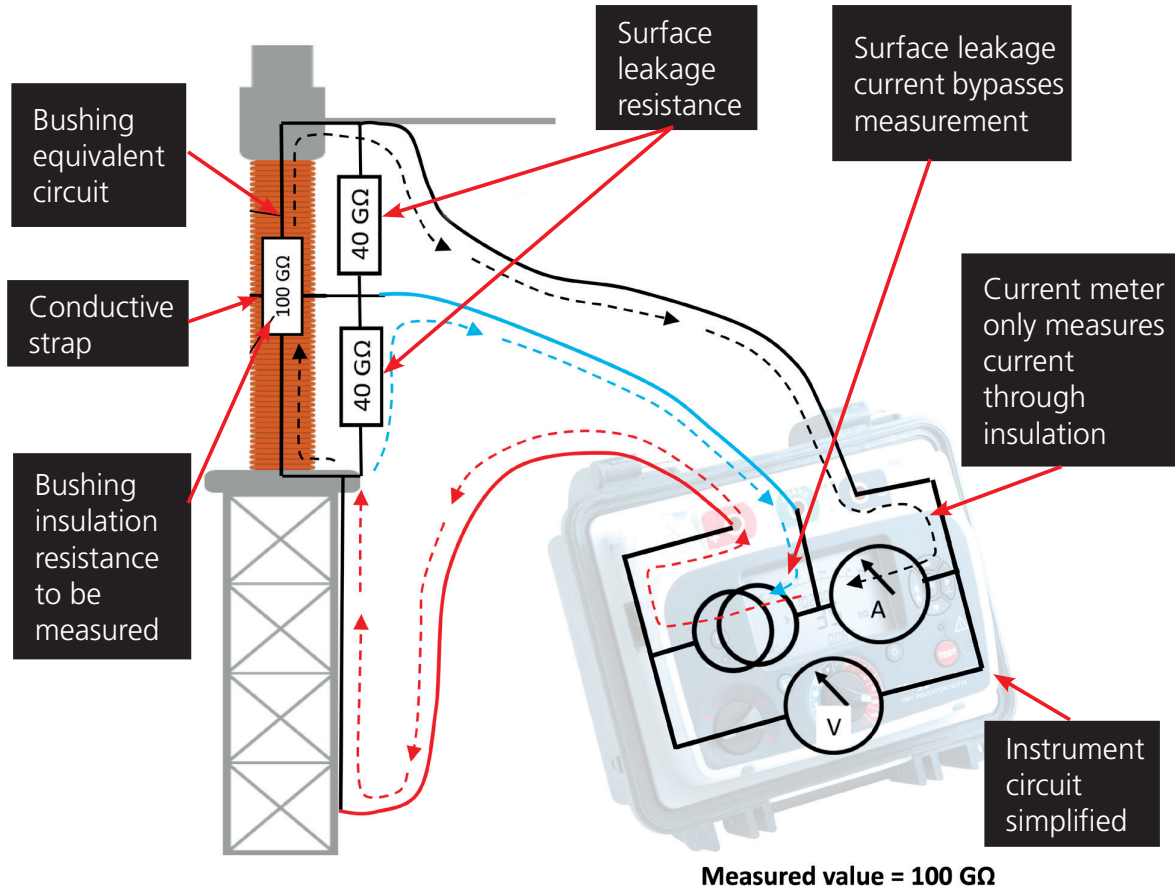

However the story doesn't end there. As you can see we have added example values to the above diagram. In this circumstance, any instrument within the Megger MIT or S1 range of insulation testers will provide measurements with no more than 1% additional error. This is an important part of the comprehensive specification these instruments provide.

The S1 5 kV and 10 kV range specify the guard terminal performance as 1% error when guarding leakage current 400 times the load current, for example, 1% error guarding 250 kΩ (worst case) across a 100 MΩ test load.

**NOTE :** with guard connected at mid-point on surface leakage path

## Why does Megger specify guard performance?

The performance of the guard terminal depends on a number of key issues. Firstly, how well the instrument's protection circuits have been designed; the EMC and CAT IV protection circuits must be of low impedance. Secondly, the instrument's current measurement circuit must also be of low

# How to get the best out of the Megger S1 range of insulation testers

resistance. Unfortunately, this is not as simple as it sounds. The Megger instrument's specification gives it the ability to provide meaningful results, and therefore properly diagnose the true condition of the insulation. Remember, effective predictive maintenance relies on reliable trending of test results to provide early indication of failure.

Time taken to carefully compensate for temperature variation can easily be wasted by poor results due to surface leakage not being correctly guarded.

## Where does this fit in with other Megger instrument specifications?

### Safety?

The importance of test instrument safety is increasingly being recognised, and insulation testers are no exception. The complete range of Megger MIT and S1 5 kV and 10 kV insulation testers are CAT IV 600 V to give the user maximum confidence. So how does this relate to the performance of the guard terminal? To be able to meet the stringent requirement of CAT IV 600 V set out in IEC61010-1: 2010, the instrument has to be protected against 8 kV high-energy impulses on ALL terminals. The challenge is to maintain both impulse protection and the test performance of the instrument. Imagine trying to absorb the high energy levels from 8 kV transients in CAT IV environments without adding any series resistance to the guard terminal.

- IEC61010-1: 2010
  - Protection against input transients between any terminals
- CAT IV 600 V
  - 8 kV transient protected Short circuit test current?

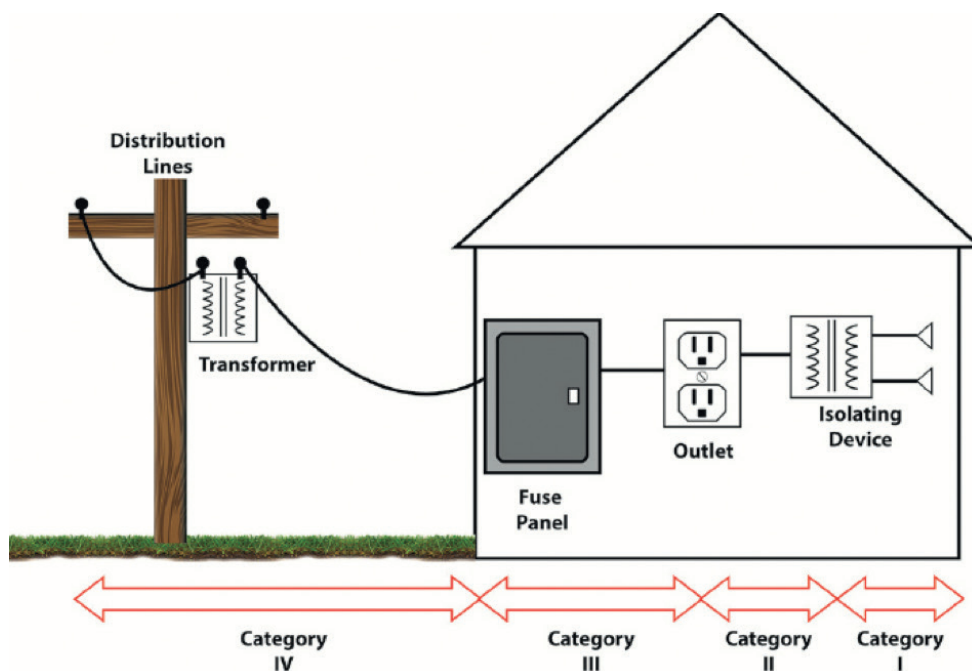

# How to get the best out of the Megger S1 range of insulation testers

The Challenge is to maintain protection and GUARD terminal performance

## Short circuit test current?

The Megger range of MIT and S1 5 kV and 10 kV insulation testers have at least 3 mA into short circuit capability. This is not just to allow the instruments to quickly charge capacitive loads such as long cables, but it also means the instruments have the power to maintain test voltages across lower resistances.

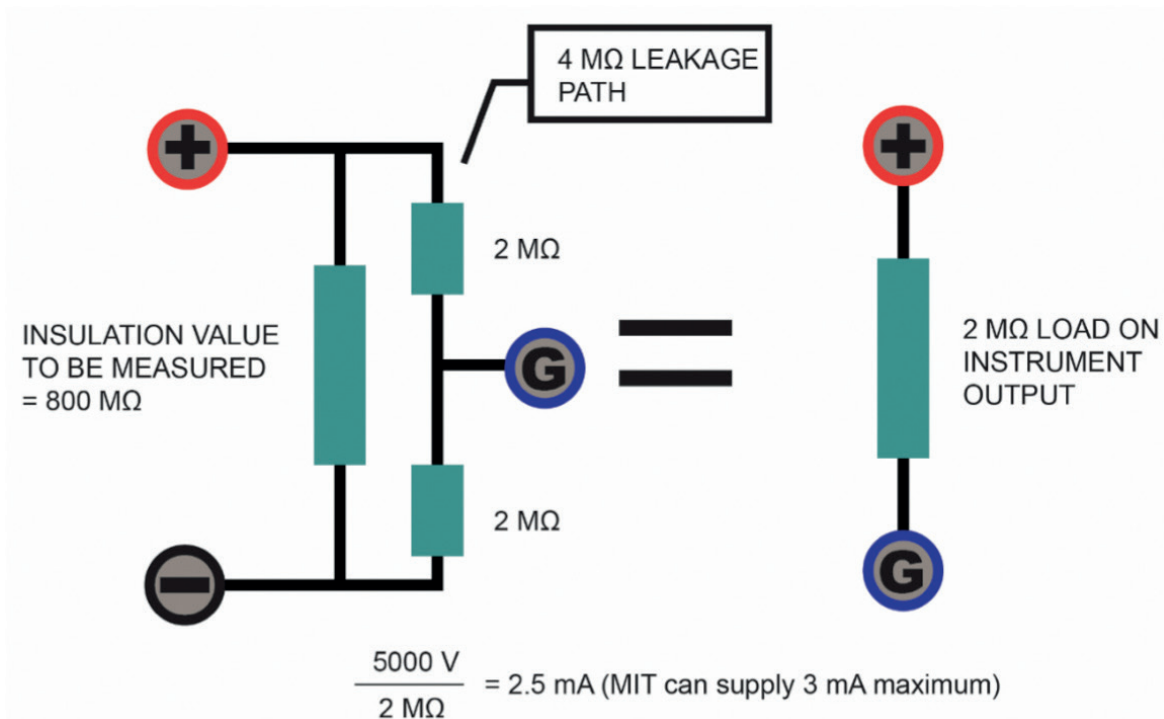

This circuit quickly demonstrates how an 800 MΩ insulation resistance can soon present a 2 MΩ load to the instrument with surface leakage. This is because the negative and guard terminals are at the same potential. High power of MIT range maintains the test voltage across the insulation and provides enough test current to accurately measure the insulation.

5000 V/2 MΩ = 2.5 mA (MIT can supply 3 mA max., S1 can supply 6 mA max.)

## Testing transformers, cables, and bushings on oil filled circuit breakers

### Testing transformers

Both the HV and LV windings of any particular phase in a three-phase transformer can be measured with respect to each other. The guard terminal eliminates the surface leakage current flowing over the outside of contaminated insulators, hence the insulation tester will be able to provide a more accurate value of the inter-winding resistance.

## How to get the best out of the Megger S1 range of insulation testers

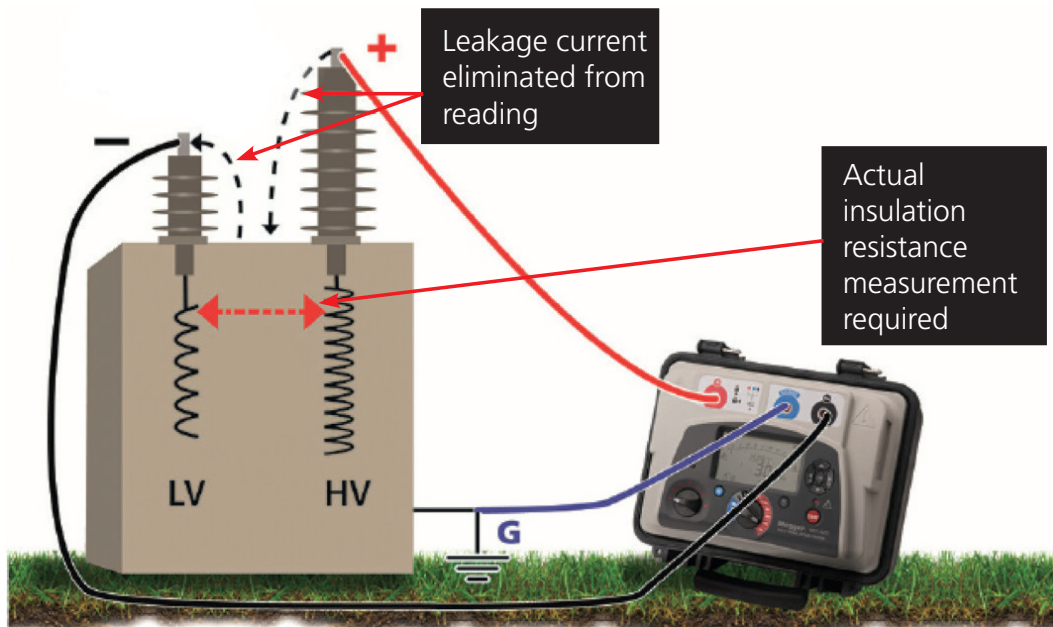

Above: a transformer winding insulation test, with the guard used to eliminate leakage current due to the surface path across dirty porcelain insulators.

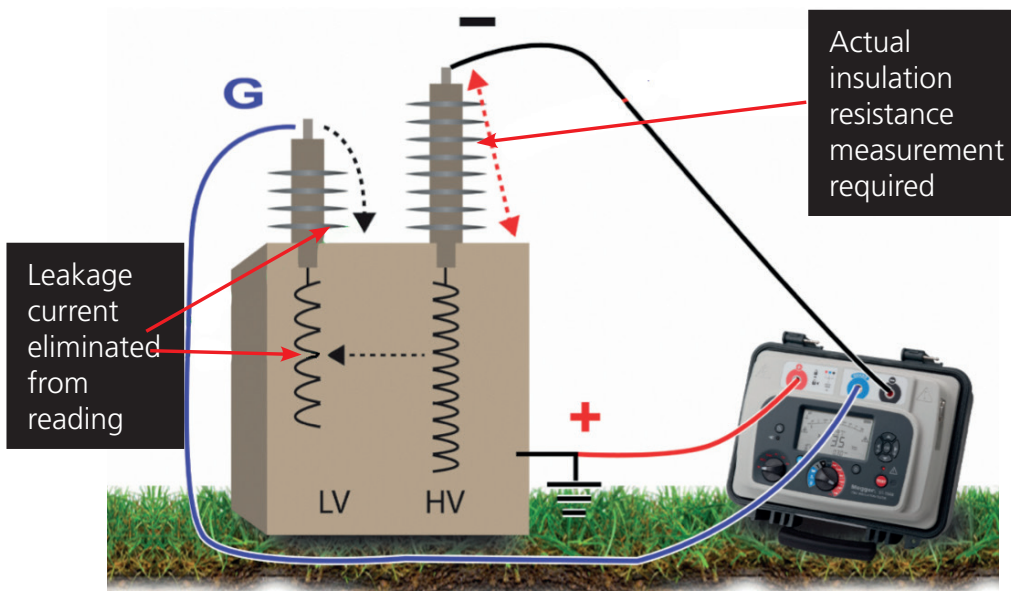

Above: the HV winding is measured without the effects of leakage current between HV and LV winding using the guard terminal.

**NOTE :** In practice, both windings on a three-phase transformer are wound concentrically on an insulated former on the same limb of the iron core, they are therefore subject to inter-turn or inter-winding breakdown, hence the need to test the insulation between the two.

# How to get the best out of the Megger S1 range of insulation testers

## Testing cables

The guard terminal is also used to remove the effects of surface leakage across exposed insulation at the ends of a cable. To measure insulation between one core and all other conductors:

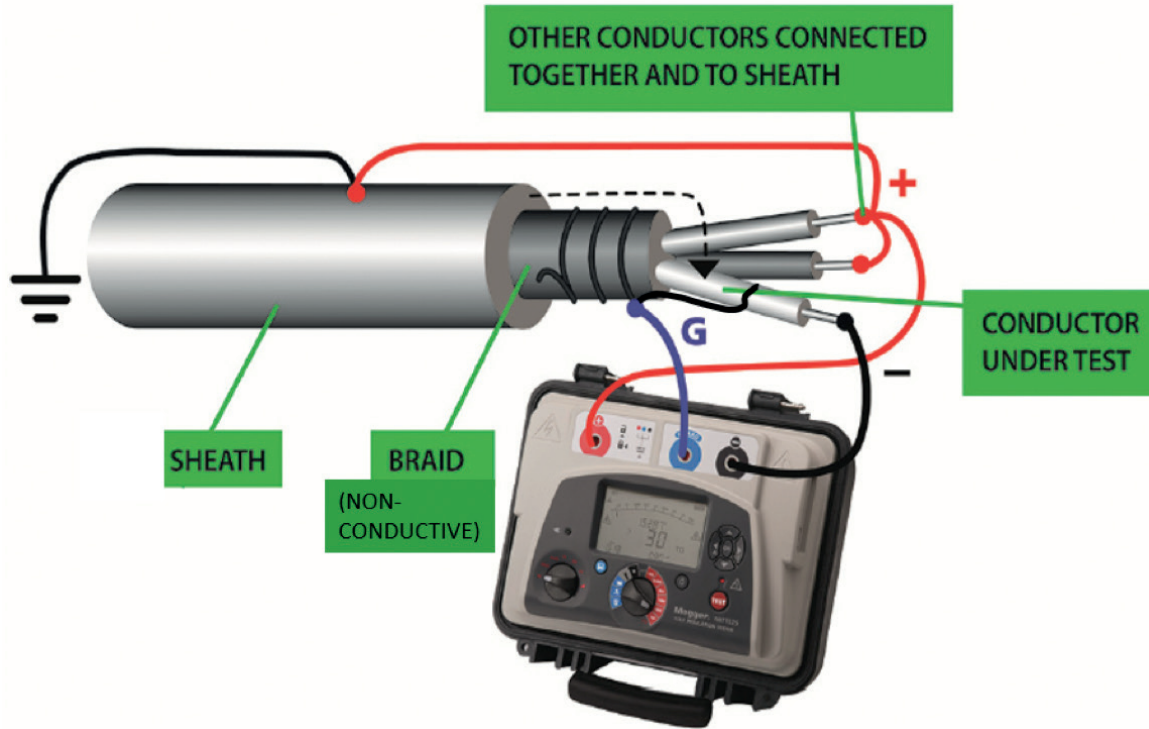

The guard terminal is connected to wire wrapped around the exposed insulation to pick up surface leakage. To measure insulation between one core and sheath only:

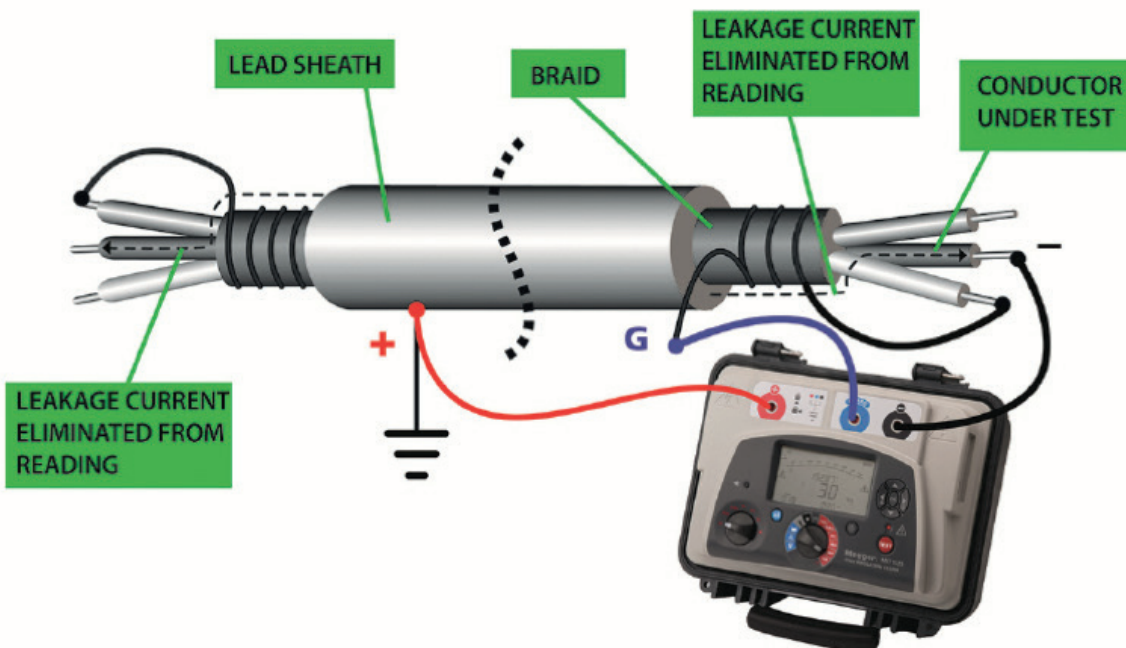

## How to get the best out of the Megger S1 range of insulation testers

In this case, a spare conductor in the cable has been used to connect the guard to the exposed insulation at the other end of the cable.

The guard terminal can also be used to eliminate leakage current between other adjacent conductors in the cable:

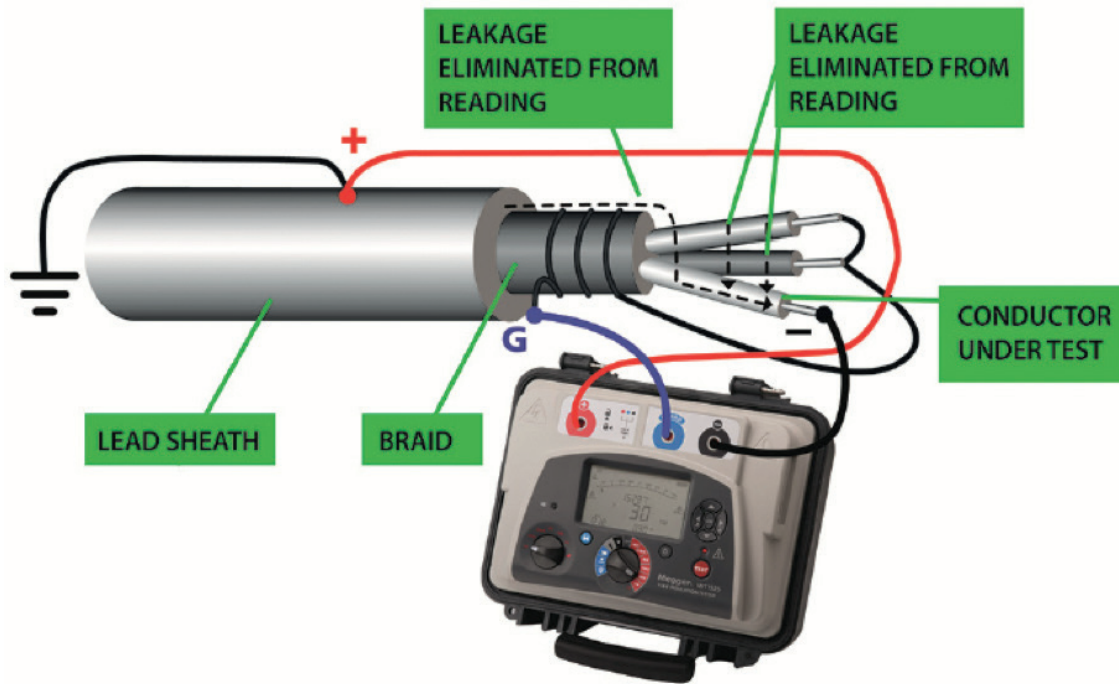

# How to get the best out of the Megger S1 range of insulation testers

## Testing bushings on outdoor oil-filled circuit breakers

The following four illustrations show the usual methods of testing bushings and associated parts of an outdoor circuit breaker.

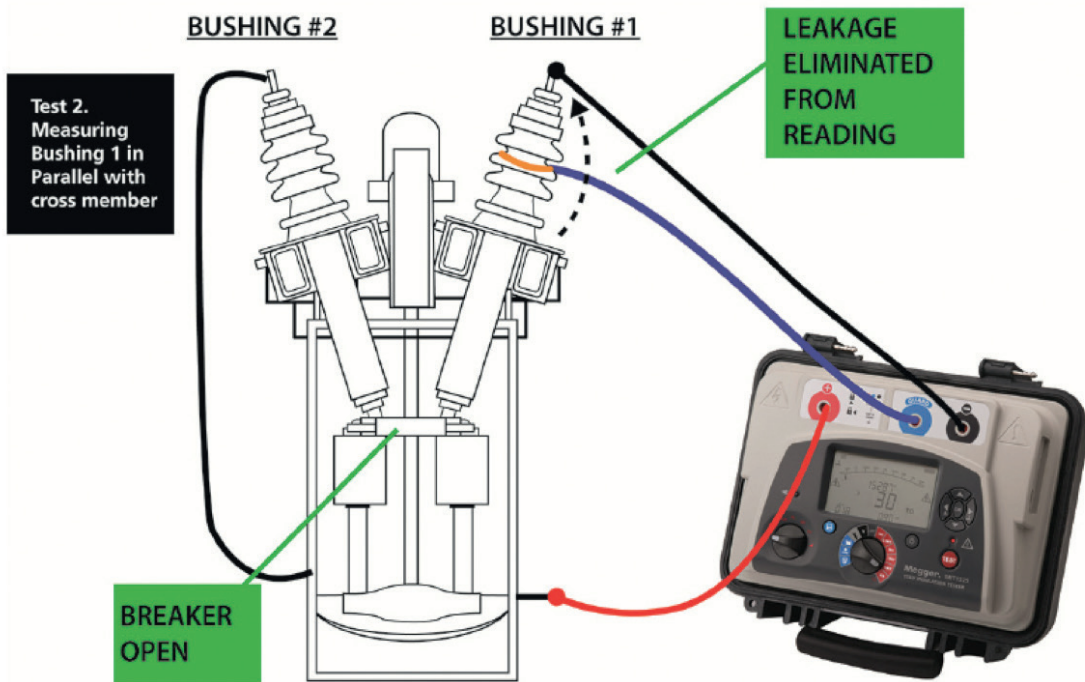
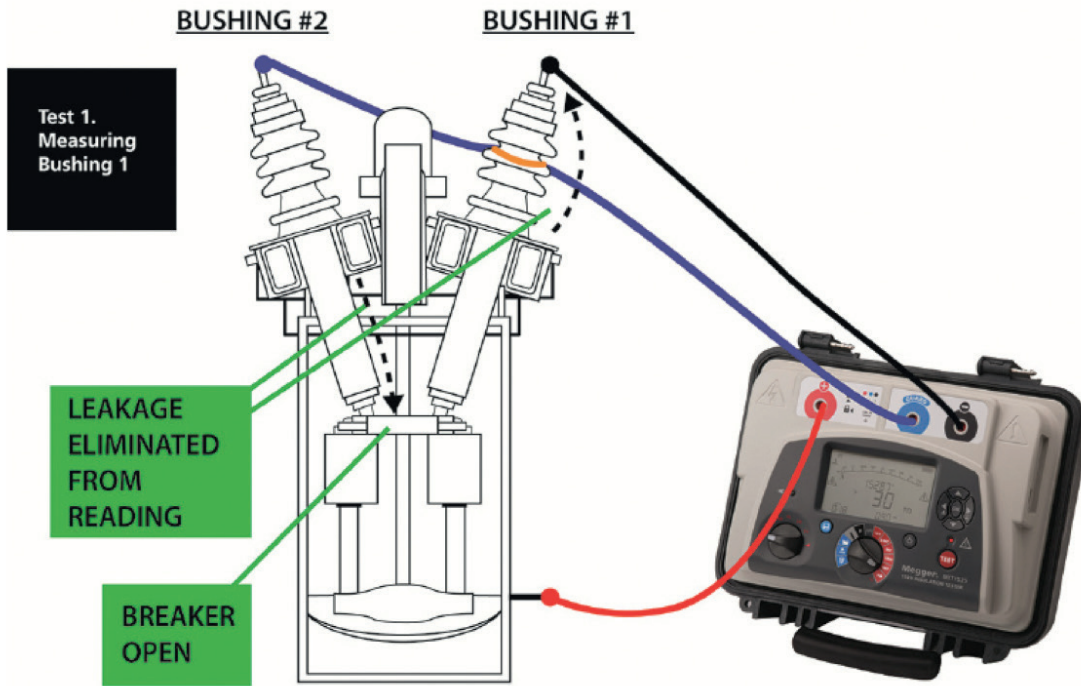

# How to get the best out of the Megger S1 range of insulation testers

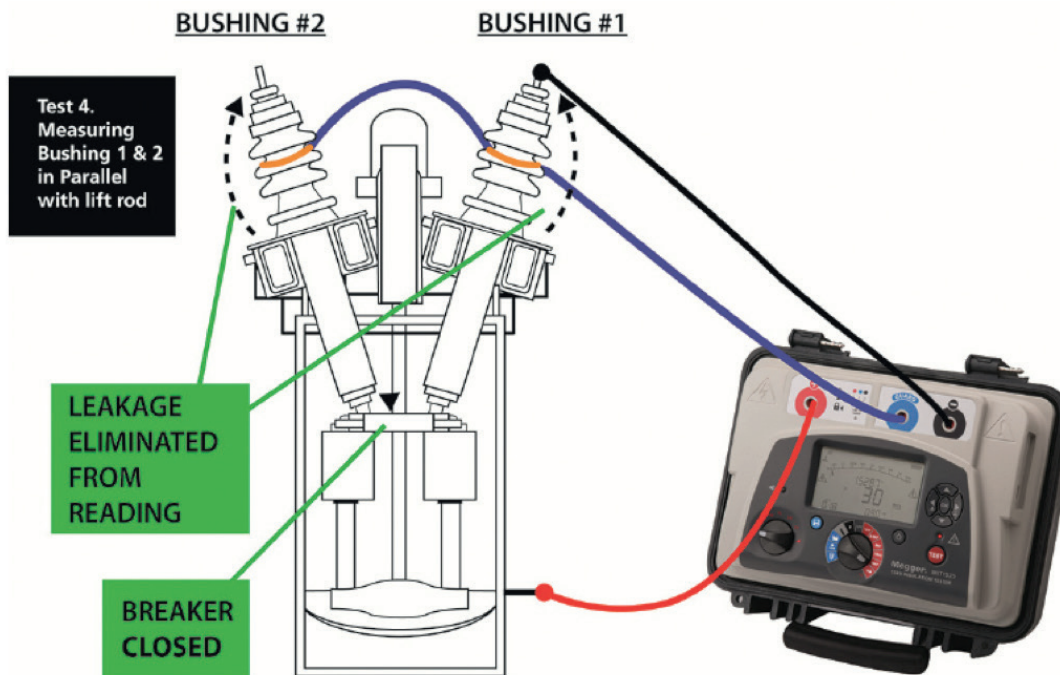
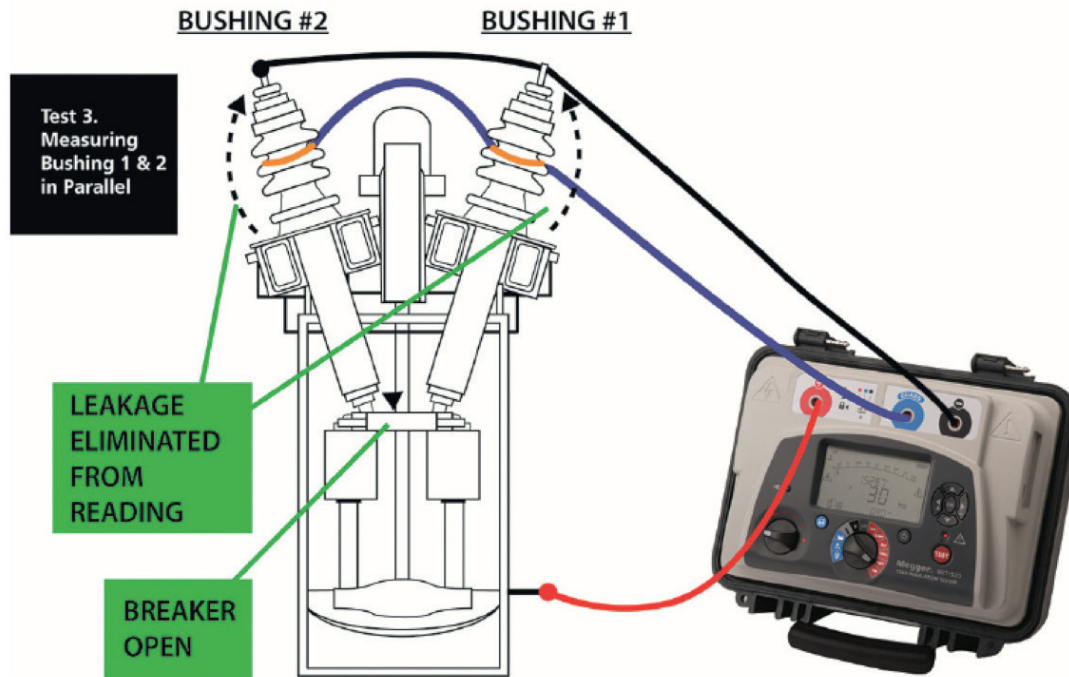

# How to get the best out of the Megger S1 range of insulation testers

## Using the guard terminal in EHV environments

### Slow variations and lower IR measurements

Using the guard terminal in the extreme EHV environment is very important. Current will flow across all the surfaces of the insulating bushings to ground and will have two major effects.

The first was mentioned earlier, where variation in wind conditions coupled with the rapid drying effect of the hot sun, and drying effect of the test voltage will cause very large variations in surface leakage. Variations that, for high resistances in the order of  $1\text{ T}\Omega$ , can be easily as large as those caused by the electrical noise interference.

The second effect will be the overall lowering of the measured IR value. Below, the paths of surface leakage are indicated. Please note that even if both circuit breakers shown are in the open condition the surface leakage will still be present.

The diagram following shows the paths of all the leakage currents flowing from the instrument to ground. This will effectively flow in parallel to the actual insulation leakage current we wish to measure. The solution is to make full use of the guard terminal to remove these currents from the measurement.

### Measurement unguarded

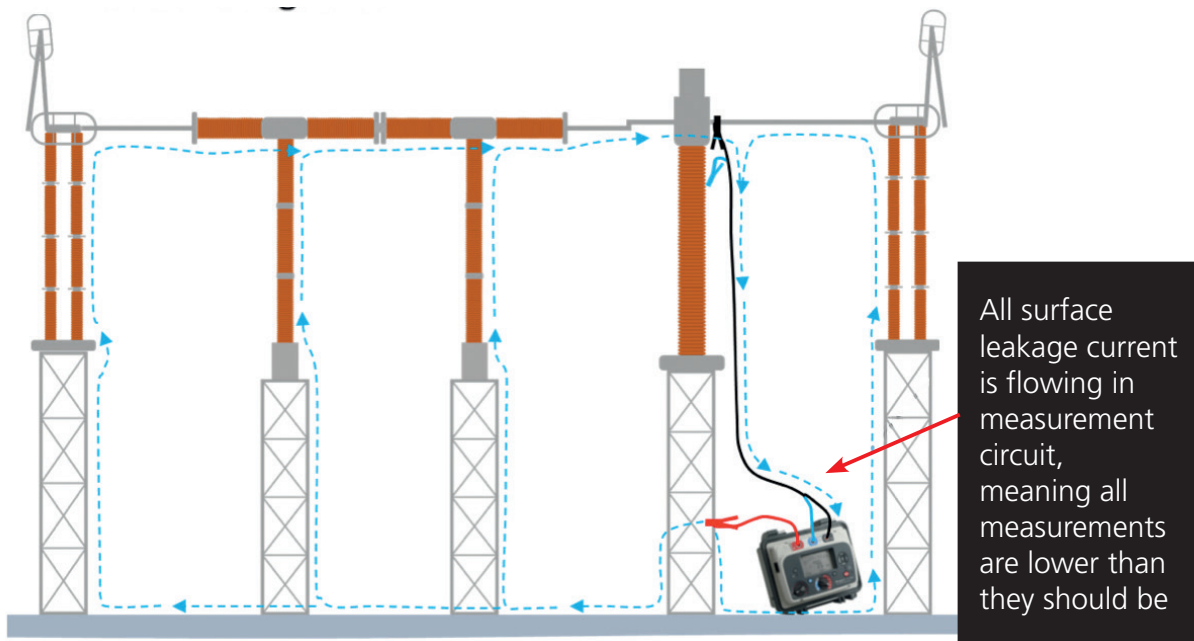

# How to get the best out of the Megger S1 range of insulation testers

## Correct connections

Making all of the required connections can be time consuming, but it will make the difference between a IR measurement being good enough to use as a go/no-go test, or a measurement accurate enough to be used for trending over time and detecting insulation degradation early enough to prevent unscheduled power loss due to insulation failure.

In EHV switch yards, making all of the required connections requires a method of making 360 degree contact with bushing surfaces to block all of the surface leakage current. Quite often, pieces of bare wire are used, however this is time consuming and does not guarantee a good contact with bushing surfaces.

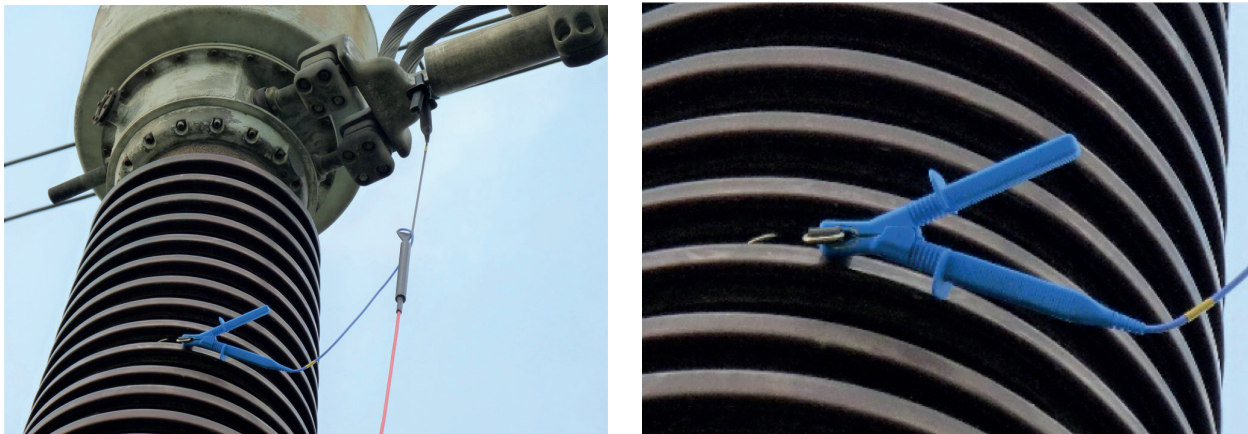

Here, an elastic conductive strap has been stretched around the bushing. The end of the straps has passed through the metal ring and secured with the lead clip.

In addition, it requires a number of suitable leads to make all of the interconnections. See below for all of the connections required:

# How to get the best out of the Megger S1 range of insulation testers

## Measurement guarded using GILS Kit

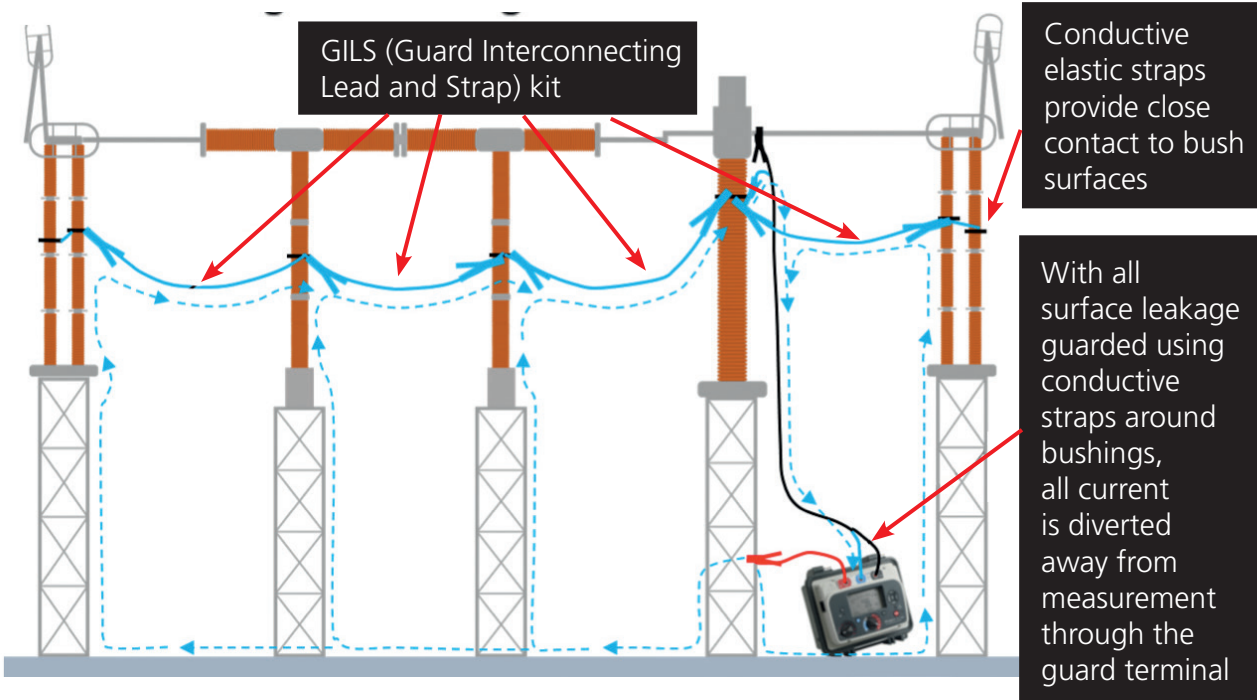

## Removing the effects of surface leakage

In the last figure it can be seen how with the conductive straps on each bushing diverts surface leakage current back to the instruments guard terminal bypassing the measurement circuit. It is essential that the input impedance of the guard terminal is lower than the negative terminal for this to be fully effective. Instruments with additional resistance will not be ideal for this application.

## Megger GILS kits

Megger have developed kits to supply everything required for effective surface leakage guarding. There are two kits available:

# How to get the best out of the Megger S1 range of insulation testers

## GILS1 Guard Interconnecting Lead and Strap kit



- Elastic conductive straps (hot collar straps)
  - 9 straps of different lengths
- Guard interconnecting leads
  - 5 m long x2
  - 12 m long x2
- Carry holdall (heavy duty)

# How to get the best out of the Megger S1 range of insulation testers

## GILS2 Guard Interconnecting Lead and Strap kit



- Elastic conductive straps (hot collar straps)
  - 9 straps of different lengths
- Guard interconnecting leads
  - 5 m long x2
  - 12 m long x2
  - 1 m long x3
  - 2 m long x3
- Carry holdall (heavy duty)
- Silicone grease

The GILS 2 kit has additional interconnecting leads for applications such as cable testing or smaller power distribution equipment.

# How to get the best out of the Megger S1 range of insulation testers

## Conclusion - The real invaluable benefits of the guard terminal

In addition to the big improvements in the reliability of insulation condition diagnosis and predictive maintenance discussed, the guard terminal is also an important diagnostic tool to simply identify surface contamination.

The amount of current that is surface leakage can be quickly identified simply by performing two tests; one using the guard terminal and one without, and calculating the difference in measurements.

There have been many instances of poor insulation resistance measurements leading to bushings etc. being replaced needlessly at huge cost, only to find later, by employing the guard terminal, that they simply needed a good clean! Don't throw away, use your guard and know when to clean.

## Other considerations

### Temperature compensation

With the large variations of temperature in India, it is even more important to correct test results to a reference temperature. With IR values changing dramatically with temperature, this is of course essential.

All of the Megger S1 range have the capability to store a value in either Centigrade or Fahrenheit for each stored test result. The feature can be switch on or off within the setting menu. These values are then downloaded to PowerDB Lite (supplied), where results can be corrected on the test record form.

### Variations in humidity and noise conditions

The Megger S1 range can also log humidity values against each stored test result. The feature can be switch on or off within the setting menu.

Changes in humidity cannot be correct for as they are for temperature, but it is still advisable to take a measurement for future reference. Should IR values increase or decrease from previous test results, it can be useful to see if those changes correlate to a change in humidity.

In addition it is always worth making a note of the noise voltage measured prior to beginning the test. Should IR values increase or decrease from previous test results it can be useful to see if those changes correlate to a change in noise conditions? However, the discharge resistance values will need to be noted and then a calculation of noise current made to make it meaningful.

# How to get the best out of the Megger S1 range of insulation testers

E.g.1 Voltage measured = 245 V ac  
Discharge resistor = 41 k ohm (value of a S1-1068-IN)  
 $245 \text{ V} / 41 \text{ k} = 5.97 \text{ mA ac}$  of induced noise current

E.g.2 Voltage measured = 122.4 V ac  
Discharge resistor = 20.5 k ohm (value of a S1-568-IN)  
 $122.4 \text{ V} / 20.5 \text{ k} = 5.97 \text{ mA ac}$  of induced noise current

E.g.3 Voltage measured = 1,194 V AC  
Discharge resistor = 200 k ohm (Example of higher value)  
 $1194 \text{ V} / 200 \text{ k} = 5.97 \text{ mA ac}$  of induced noise current

## Trending test results

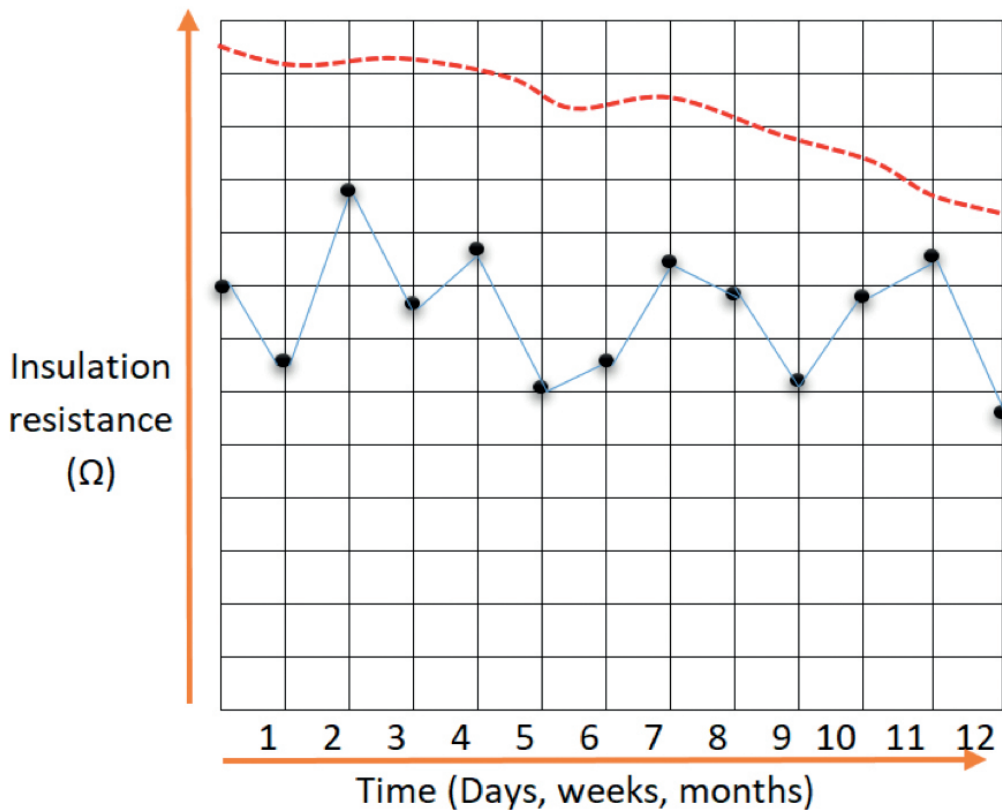

Sometimes the value of trending test results is not always apparent. However, this is usually because either temperature correction has not been performed, or it could be due to poor guarding of surface leakage or maybe inaccurate measurements from instruments unable to cope with noise or negative transient currents. However, by taking some steps outlined in this application note, results can be changed from those looking like the blue line, to those looking like the dotted red line.

Notice the higher values due to the surface leakage not being measured in a properly guarded system. Trending test results can provide early warning of insulation degradation, meaning that failures can be prevented.

## Safety considerations

No Megger application note would be complete without safety warnings. The Megger reputation worldwide has of course been built by ensuring all instruments are designed to last, are reliable, provide accurate and repeatable measurements, and are safe. All Megger product designs are comprehensively tested in our own facilities to maintain our reputation.

When it comes to safety, as you would expect from Megger, there is a no-compromise approach. Below are some considerations to take into account when testing in the power distribution and transmission environments:

### Inadvertent connection to live voltages

In locations where live voltages below 1000 V are present, the main hazard can be arc flash over. With over 80% of injuries here being burns from arc flash over, it is a real hazard.

Megger take this hazard very seriously with unique safety features:

- CAT IV 600 V rating and 1000 V protection between every test terminal, including the guard terminal
- Dual case construction. The inner case provides the fire-retardant properties required to contain any fire resulting from arc flash over. The outer case maintains maximum strength to maintain integrity, reducing the chance of unnoticed cracks or damages that could prove very hazardous
- Live voltage warning with active test inhibit
- Voltage measurement to allow the user to see voltage decay during discharge

**NOTE :** When testing long power cables the hazard will be the lethal capacitive charge. If this is not discharged safely following a test, the results can potentially be fatal. Megger has again some distinctive and unique safety features here too:

- Lockable test leads to prevent inadvertent disconnections

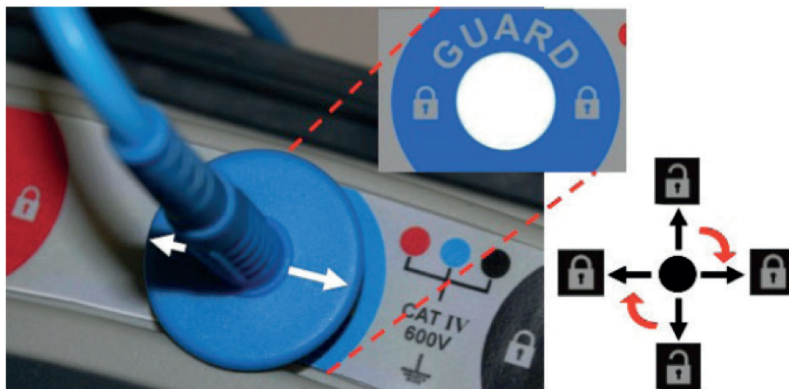

## Safety considerations

- Fully touch-proof insulated test clips

Megger's unique solution has been achieved by the addition of moving jaw covers that flex back when the clip is applied to a test piece.



- Test clips that cannot be detached, again to prevent inadvertent disconnection

Cable strain relief at both clip and plug designed to withstand 5000 flexes with 10 N pull force applied



## Safety considerations

### Test lead markings and ratings

Megger provides a range of lead sets and clips of different sizes and electrical characteristics for use with Megger 5 kV, 10 kV and 15 kV insulation resistance testers, enabling the user to choose the best lead set for the work in hand.

The design of the lead sets facilitates connection to a variety of de-energised systems for the purpose of making insulation resistance measurements. In all cases, it is the responsibility of the user to employ safe working practices and verify that the system is safe before connection.

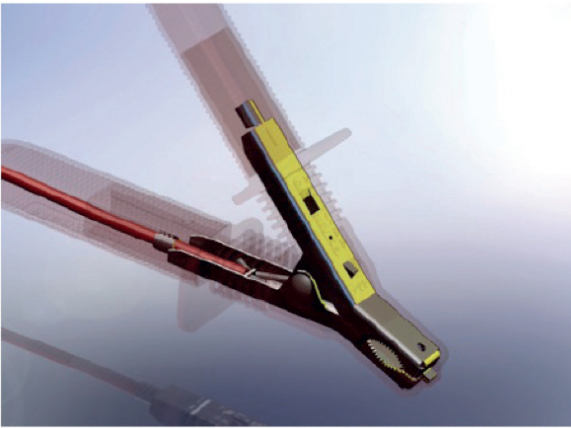

Even electrically isolated systems may exhibit significant capacitance, which will become dangerously charged by the application of the insulation test. Connections, including the leads and clips, should never be touched during the test. The system must be safely discharged before touching connections.

# Safety considerations

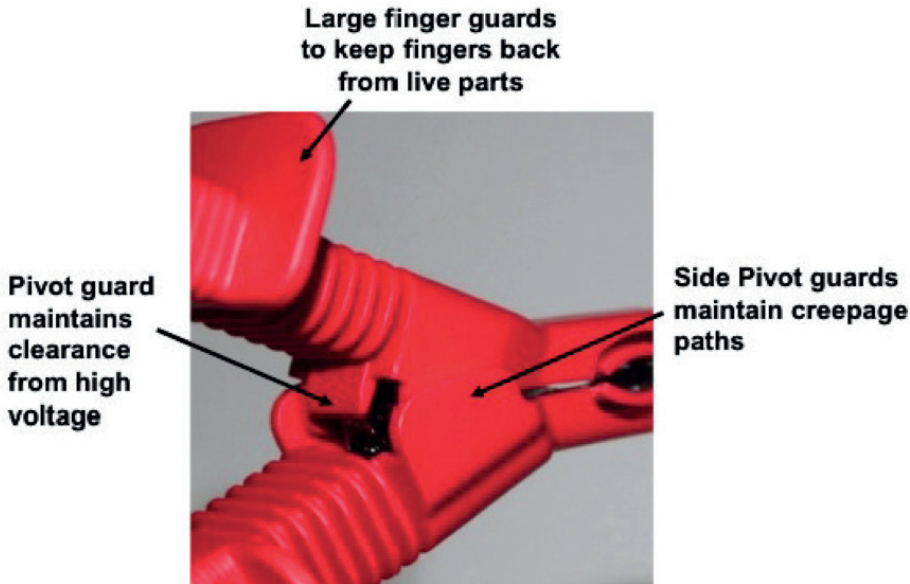
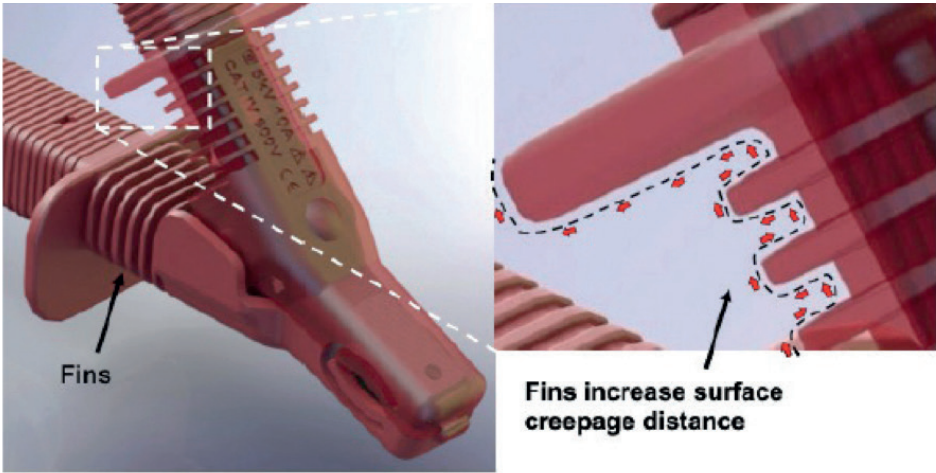

Test clip markings explained with respect to protection to instrument output:

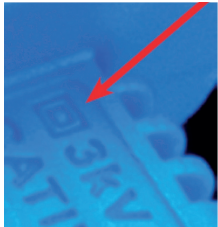

The 'double-square' symbol means 'double insulation' providing protection from electric shock to the rated voltage. The clips may be handled safely up to this voltage, provided hands are kept behind the figure guards. The clip provides only basic insulation up to a voltage twice the rating. In this case the clips may be used safely up to 6 kV, but must not be touched when energised above 3 kV. Likewise a clip marked double insulated to 5 kV may be handled up to that voltage. It provides basic insulation, and may be used up to 10 kV but must not be touched if energised above 5 kV.

## Safety considerations

### Induced current, measured voltage and making or changing connections

Earlier in this application note it was demonstrated how, in EHV environments, the voltage measured by the instrument is purely a function of the discharge resistor in circuit while the voltage is measured. The induced current flowing is effectively a constant, so the voltage can increase dangerously if this resistance is removed.

The user **MUST NOT** assume that only the measured voltage will be present at the test lead plug if it is removed from the instrument. In fact, the voltage could rise to many thousands of volts and draw huge arcs. Always take extreme care.



- No test lead or termination should be touched unless safety grounds are in place
- Do not touch leads or terminations if there is any doubt as to the quality of safety ground connections.

**Please refer to the full safety warnings provided in both the instrument and test lead set user guides**





**Megger**<sup>®</sup>

1.800.561.8187

www.**itm**.com

information@itm.com