

## Wheel measuring head 16mm

Application information



## Application

The vane measuring probes 0635 9542 and 0635 9552 are suitable in conjunction with the testo 480 for flow measurements in ventilation ducts.



Observe the information on the measuring process in the instrument instruction manual.

---

## Overview



- 1 Vane measuring probe
- 2 Telescope with scale
- 3 Handle with integrated measurement button
- 4 Connection for plug-in head cable (item no. 0430 0100)
- 5 Telescope cable

**Technical data for 0635 9542**

| Feature                           | Values   |
|-----------------------------------|--|
| Measuring range                   | +0.6 to +50 m/s<br>-10 to +70 °C (probe head)  |
| Accuracy: (at 22 °C)<br>± 1 digit | 0.6 to 40 m/s: ±(0.2 m/s, +1 % of m.v.)<br>40.1 to 50 m/s: ±(0.2 m/s, +2 % of m.v.)<br>±1.8 °C |
| Operating range<br>(handle)       | 0 to +40 °C  |
| Resolution                        | 0.1 m/s  |

**Technical data for 0635 9552**

| Feature                           | Values  |
|-----------------------------------|---|
| Measuring range                   | 0.6 to 50 m/s<br>-30 to +140 °C (probe head)  |
| Accuracy: (at 22 °C)<br>± 1 digit | 0.6 to 40 m/s: ±(0.2 m/s + 1% of m.v.)<br>40.1 to 50 m/s: ±(0.2 m/s + 2% of m.v.)<br>± (2.5 °C + 0.8 % of m.v.) |
| Operating range<br>(handle)       | 0 to +40 °C   |
| Resolution                        | 0.1 m/s   |

**Adjustment conditions**

Adjustment in free jet 350 mm, reference pressure 1013 hPa, probe head point marking exposed to the flow, based on testo reference Laser Doppler Anemometer (LDA).



The digital probe allows readings to be processed directly in the probe. This technology eliminates instrument measurement uncertainty.

For calibration, the probe alone (without the handheld instrument) can be sent away.

Calculating the determined calibration data in the probe generates a zero-error display.

## Preparing for measurement

---



Vanes are impact-sensitive!

The vanes may only be used within the specified temperature range.

Aggressive or contaminated media may damage the measuring head.

---

- > Remove protective cap from the probe head.
- > Pull out the telescope to the required length. The individual joints of the telescope click into place.

## Measuring flows

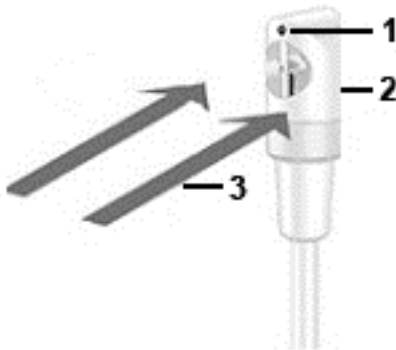

- 1 Point marking
- 2 Probe head
- 3 Direction of flow

- > Position the probe head (2) in the flow so that the point marking (1) shown on the probe head is exposed to the flow. The direction of flow (3) must be parallel to the vane axis.
- > The display value on the measuring instrument is changed by turning the measuring probe slightly in the air flow. The measuring probe is positioned exactly right if the display value is the maximum possible.
- > Pressing the measurement button on the probe handle triggers the recording of measurement data within a measurement program.

**After the measurement**

- > After using the probe 0635 9552 within the temperature range above 70 °C, let the probe cool down.
- > Pull the protective cap over the probe head.
- > Slide the telescope back, starting with the joints closest to the handle. Make sure that there are no kinks in the telescope cable.